



User Manual

Residential Energy Storage Battery Pack

CoreX 5 Elite

Version 1.0



Statement

Before installing, operating, or maintaining this equipment, carefully read this document in its entirety and strictly follow all safety instructions provided herein and on the equipment.

The safety alerts, including but not limited to DANGER, WARNING, CAUTION, and NOTICE statements, do not and cannot cover all potential hazards. To the maximum extent permitted by applicable law, SUNGOLDPOWER shall not be liable for any consequences arising from failure to comply with safety requirements or applicable standards related to the design, installation, operation, or use of the equipment.

This equipment must be used only under conditions that meet the design specifications. Otherwise, the equipment may malfunction, sustain damage, or operate under unsafe conditions, none of which are covered under the warranty. SUNGOLDPOWER shall not be responsible for any property damage, personal injury, or serious injury or death resulting from improper use.

Users and installers must comply with all applicable laws, regulations, codes, and industry standards during installation, operation, use, and maintenance. The safety precautions contained in this manual are intended to supplement, not replace, local, national, or international regulatory requirements.

SUNGOLDPOWER shall not be liable under any of the following circumstances, including but not limited to:

- Failure to follow the operating instructions or safety warnings.
- Operation of the equipment outside the conditions and parameters specified in this document.
- Installation, commissioning, or use performed by unqualified or unauthorized personnel.
- Unauthorized disassembly, reassembly, modification of the product, or alteration of firmware or software code.
- Installation or operation of the equipment in environments that do not comply with applicable international, national, regional, or industry standards.
- Damage caused by improper transportation or handling that does not meet the specified requirements.
- Damage resulting from improper storage conditions.
- Equipment damage or failure caused by force majeure events, including but not limited to natural disasters, war, or other events beyond reasonable control.

Content

1	Preface	1
1.1	Purpose	1
1.2	Target Audience	1
1.3	Document Usage	1
1.4	Symbol Conventions	2
2.	Parameters, Specification, and Function	3
2.1.	Overview	3
2.2.	Appearance and Dimensions	3
2.3.	Specification and Parameters	4
2.4.	Interface	5
2.5.	Communication Interface and Definitions	7
2.6.	Indicator Status Description	8
2.6.1.	LED Indicator	8
2.6.2.	LED Status Indicator	8
2.6.3.	LED Flash Mode Description	9
2.7.	Battery Manage System	10
2.7.1.	Main Interface	10
2.7.2.	Home Menu	12
2.7.3.	Cell Information Interface	12
2.7.4.	Protocol Selection Interface	12
2.7.5.	Status Information Interface	13
2.7.6.	System Setting Interface	13
3.	Blue tooth and Wi-Fi communication	13
3.1.	APP Download	13
3.2.	APP Dynamic Permissions	14
3.3.	Control Methods	14
3.4.	Local Control (BLE)	15
3.5.	Remote Control (Wi-Fi)	15
3.5.1.	Account Registration and Login	15
3.5.2.	Device List	16
3.5.3.	Adding a Device	16

4. Product Installation	19
4.1. Installation Flow Chat	19
4.2. Tool Preparation	19
4.3. Pre-installation Check	20
4.3.1. Packing List.....	20
4.3.2. Unpacking Inspection	22
4.3.3. Preparations.....	22
4.3.4. Power-On/Power-Off Check	22
4.3.5. Important Notes.....	22
4.4. Installation	23
4.4.1. Battery Pack Installation	23
4.4.2. Connection of Power Cable	24
4.4.3. Connection of Communication Cable.....	24
4.4.4. Grounding	25
4.4.5. Battery Pack Parallel Connection	25
4.5. Post-installation Inspection	27
4.6. System Power On/Off.....	27
4.6.1. System Power On.....	27
4.6.2. System Power Off	28
4.6.3. Sleep and Wake-up.....	28
5. Instruction	29
6. Fault and Emergency Handling	30
6.1. Common Fault Handling	30
6.2. Emergency Handling	30

1 Preface

1.1 Purpose

This document introduces the residential low-voltage wall-mounted system: CoreX 5 Elite in terms of the product composition, installation, commissioning, system operation and maintenance, and troubleshooting. Have a good understanding of the product features, functions, and safety precautions provided in this document before installing and operating the energy storage system.

1.2 Target Audience

This document is intended for installers and maintenance electricians of energy storage systems. All installation operations must be completed by professional technicians only. Technicians must meet the following requirements:

- Have received specialized training and be qualified
- Read this document thoroughly and master the safety precautions related to operation
- Familiar with local standards and relevant safety regulations for electrical systems

1.3 Document Usage







Before using the product, please read the document carefully and store it in a convenient place for easy access.

In order to continuously improve customer satisfaction, both this product and the product document are continuously being improved and upgraded. If there is a discrepancy between the received manual and the product, it may be due to a product version upgrade. Please refer to the actual product.

The document content will be continuously updated and revised, but it is inevitable that there may be slight discrepancies or errors with the actual product. Please refer to the actual product purchased by the user. The pictures mentioned in this document are for reference only and the actual product shall prevail.

1.4 Symbol Conventions

The symbols that may be found in this document or on the products are defined as follows:

Symbol	Description
	<p>This indicates a hazard with a high level of risk which, if not avoided, will result in death or serious injury.</p>
	<p>This indicates a hazard with a medium level of risk which, if not avoided, could result in death or serious injury.</p>
	<p>This indicates a hazard with a low level of risk which, if not avoided, could result in minor or moderate injury.</p>
	<p>This indicates a potentially hazardous situation which, if not avoided, could result in equipment damage, data loss, performance deterioration, or unanticipated results. NOTICE is used to address information not related to personal injury.</p>
	<p>Supplements the important information in the main text. NOTE is used to address information not related to personal injury, equipment damage, and environment deterioration.</p>
	<p>Indicates that the product is electronic waste, must be sent to specialized recycling facilities. It is prohibited to discard with household waste.</p>

2. Parameters, Specification, and Function

2.1. Overview

The residential low-voltage wall-mounted energy storage battery pack (CoreX 5 Elite) is primarily designed for residential use as an energy storage and conversion device. In areas with unstable power supply, it can serve as an emergency backup to ensure household electricity; in regions with high electricity prices, it can be paired with solar photovoltaics for self-consumption; in areas with significant peak-valley electricity price differences, it can be used for peak shaving and valley filling to reduce household electricity costs. The product integrates an industry-leading BMS (Battery Management System), enabling real-time and precise monitoring of battery health status (SOC/SOH) and key parameters. It is equipped with multiple active safety protection features to effectively prevent risks such as overcharging, over-discharging, short circuits, and overheating, ensuring safe and stable operation of the device. It is a reliable safeguard for household electricity.

2.2. Appearance and Dimensions

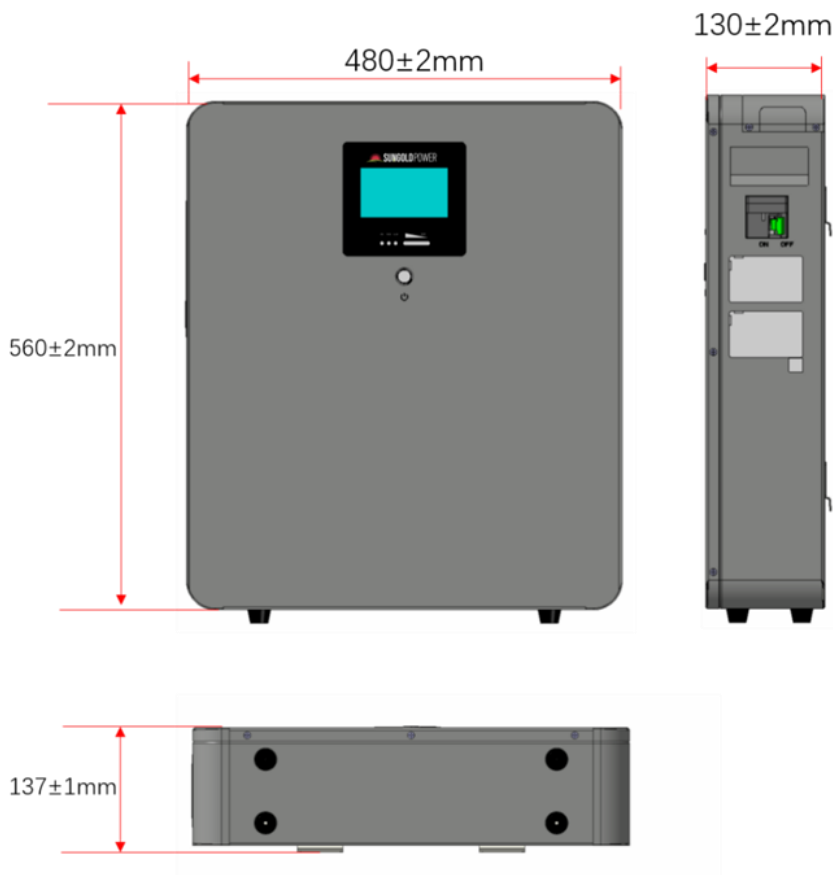

Figure2-1 Appearance and dimensions

2.3. Specification and Parameters

Table2-1 Parameters of battery pack

No.	Item	Specification	Remark
1	Configuration	1P16S	
2	Rated capacity	100Ah	
3	Rated voltage	51.2V	
4	Rated energy	5.12kWh	
5	Voltage range	43.2 V~56.8V	
6	Charging current limit	20A	The current limit switch is enabled by default, when the charging current is $\geq 90A$, it triggers 20A current limit
7	Standard charge/ discharge current	50A	25 \pm 2 $^{\circ}$ C
8	Maximum charge current	95A	0.95C When current limiting is disabled and the charge current reaches 96A, the battery charge over-current protection will be triggered.
9	Maximum discharge current	100A	25 \pm 2 $^{\circ}$ C (77 \pm 35.6 $^{\circ}$ F)
10	Recommended temperature range for use	10 $^{\circ}$ C~45 $^{\circ}$ C (50 $^{\circ}$ F~113 $^{\circ}$ F)	
11	Operating temperature	Charge	4 $^{\circ}$ C~55 $^{\circ}$ C (39.2 $^{\circ}$ F ~131 $^{\circ}$ F)
		Discharge	-20 $^{\circ}$ C~55 $^{\circ}$ C (68 $^{\circ}$ F~131 $^{\circ}$ F)
12	Humidity range	5~85% RH, no condensation	
13	Storage humidity	Within 1 month	-20 $^{\circ}$ C~45 $^{\circ}$ C (68 $^{\circ}$ F~113 $^{\circ}$ F)
		Within 1 year	0 $^{\circ}$ C~35 $^{\circ}$ C (32 $^{\circ}$ F~95 $^{\circ}$ F)
14	Storage humidity	<60% RH, no condensation	
15	Dimension D*W*T	(560 \pm 2)*(480 \pm 2)*(137 \pm 1)mm ~22.05*18.9*5.39 inch	
16	Weight	48 \pm 2kg(Net weight) ~105.82 lb	
17	IP rating	IP20	
18	Application altitude	\leq 3000m (~9842.5ft)	

2.4. Interface

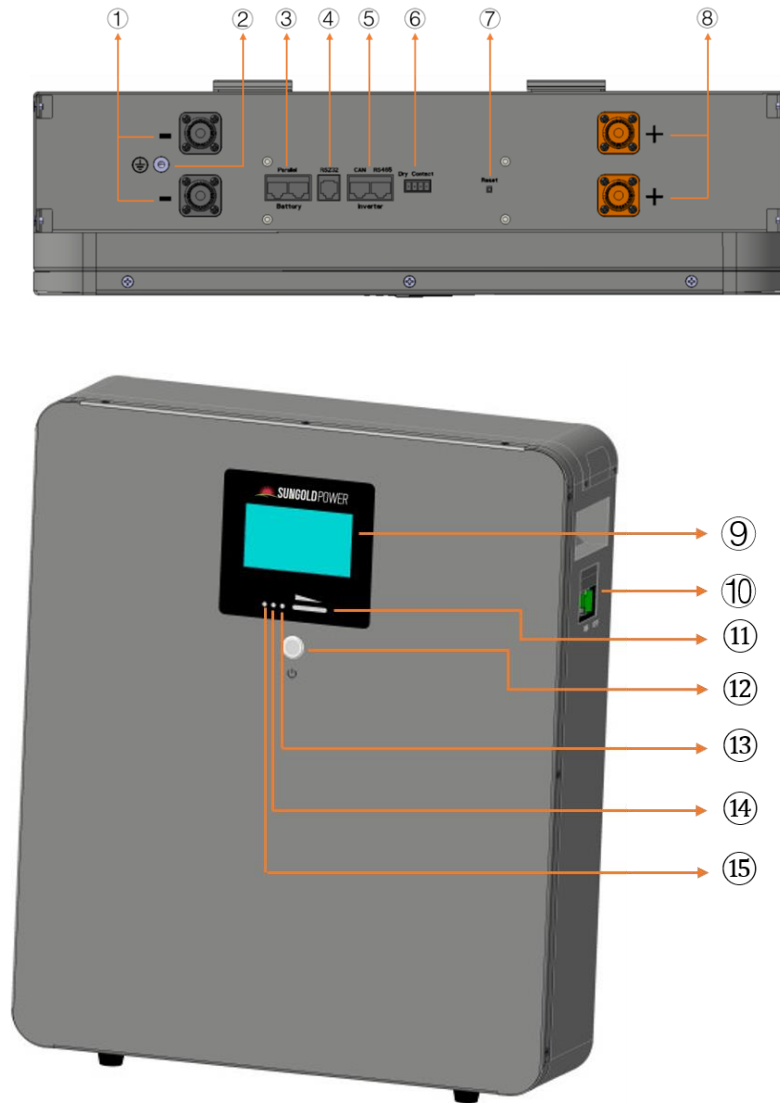

Figure 2-2 The diagram of interface

Table2-2 Definition of external interface

No.	Item	Description	
1	P-	Battery pack negative	For output or pack paralleling
2	Grounding	Grounding point	
3	Parallel communication	Parallel communication input	For communication between parallel packs
		Parallel communication output	
4	RS232	RS232 communication	Debug

5	Inverter communication	CAN communication	For communication with PCS/inverter
		RS485 communication	
6	Dry contact	Dry contact communication	
7	Reset	Reset button	
8	P+	Battery pack positive	For output or pack paralleling
9	Screen	BMS display screen	
10	Breaker	Breaker	
11	SOC	SOC indicator	
12	Power ON/OFF	Power button	
13	Alarm	Alarm indicator	
14	RUN	Operating indicator	
15	ON	Power on indicator	

2.5. Communication Interface and Definitions

Table2-3 Communication interface and definitions

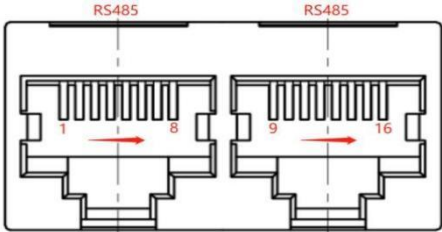
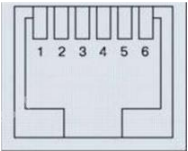
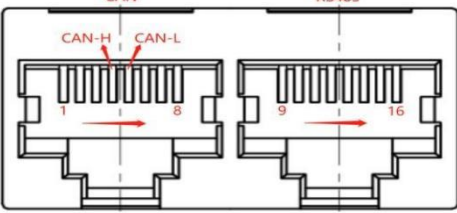
Communication terminal	Pin No.	Definition	Diagram
RS485: RJ45 socket	1, 8	RS485-B	 <p>Parallel communication</p>
	2, 7	RS485-A	
	3, 6	GND	
	9, 16	RS485-B	
	10, 15	RS485-A	
	11, 14	GND	
RS232: RJ11 socket	1, 2, 6	NC	 <p>RS232 communication</p>
	3	TX	
	4	RX	
	5	GND	
CAN, RS485: RJ45 socket	2	GND	 <p>Inverter communication</p>
	4	CAN-H	
	5	CAN-L	
	9, 16	RS485-B1	
	10, 15	RS485-A1	
	11, 14	GND	
1, 3, 6, 7, 8, 12, 13	NC		

2.6. Indicator Status Description

2.6.1. LED Indicator

The LED indicators consist of a Power-on Indicator, Run Indicator, Alarm Indicator, and SOC Indicator. The SOC Indicator is composed of six bead-like LED lamps, arranged from left to right as L6, L5, L4, L3, L2, and L1.

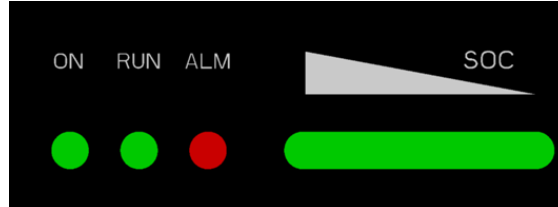

Figure 2-3 Diagram of LED indicator lights

2.6.2. LED Status Indicator

Table2-4 Descriptions of SOC indicators

Status		Charge						Discharge					
SOC indicator		L6●	L5●	L4●	L3●	L2●	L1●	L6●	L5●	L4●	L3●	L2●	L1●
S O C	0-17%	Off	Off	Off	Off	Off	Flash 2	Off	Off	Off	Off	Off	Steady on
	18-33%	Off	Off	Off	Off	Flash 2	Steady on	Off	Off	Off	Off	Steady on	Steady on
	34-50%	Off	Off	Off	Flash 2	Steady on	Steady on	Off	Off	Off	Steady on	Steady on	Steady on
	51-66%	Off	Off	Flash 2	Steady on	Steady on	Steady on	Off	Off	Steady on	Steady on	Steady on	Steady on
	67-83%	Off	Flash 2	Steady on	Steady on	Steady on	Steady on	Off	Steady on	Steady on	Steady on	Steady on	Steady on
	84-100%	Flash 2	Steady on	Steady on	Steady on	Steady on	Steady on	Steady on	Steady on	Steady on	Steady on	Steady on	Steady on
RUN indicator	●	Steady on						Flash 3					

Table 2-5 LED Operating Status Indicators

Status	Normal/Sleep/ Alarm/Protection	ON/OFF ●	RUN ●	ALM ●	SOC indicator ●	Description
Off	Sleep	Off	Off	Off	Off	All Off
Standby	Normal	Steady on	Flash 1	Off	Indicates based on power level	Standby Mode
	Alarm	Steady on	Flash 1	Flash 3		Battery Module Under-Voltage
Charge	Normal	Steady on	Steady on	Off	Indicates based on power level (battery indicator maximum LED flash 2)	The highest power LED flashes (2 flashes), and the ALM does not flash during overcharge alarm.
	Alarm	Steady on	Steady on	Flash 3		
	Overcharge protection	Steady on	Steady on	Off	Steady on	Indicators switch to standby mode in the absence of grid power
	Temperature, overcurrent, failure protection	Steady on	Off	Steady on	Off	Charge Stop
Discharge	Normal	Steady on	Flash 3	Off	Indicates based on power level	
	Alarm	Steady on	Flash 3	Flash 3		
	Undervoltage protection	Steady on	Off	Off	Off	Discharge Stop
	Temperature, overcurrent, short circuit, reverse polarity protection, failure protection	Steady on	Off	Steady on	Off	Discharge Stop
Failure		Off	Off	Steady on	Off	Charge/Discharge Stop

2.6.3. LED Flash Mode Description

Table2-6 LED Flash Mode Description

Flash mode	On	Off
Flash 1	0.25S	3.75S
Flash 2	0.5S	0.5S
Flash 3	0.5S	1.5S

2.7. Battery Manage System

Adopts a primary BMS (Battery Management System) capable of monitoring the voltage, current, and temperature within the battery pack, while also performing real-time precise calculations of SOC and SOH. When multiple battery packs are connected in parallel, the BMS of the first battery pack acts as the master BMS (master unit), aggregating information such as voltage and current from the slave battery packs and handling external communication. Its main functions are as follows:

Operational control functions: Including start/stop control, charge/discharge control, operational parameter settings, and thermal management control.

Data acquisition functions: The BMS should be able to measure electrical and thermal-related data in real time, including parameters such as individual cell voltage, battery module temperature, battery module voltage, series circuit current, and insulation resistance.

Alarm and protection functions: The BMS provides electrical protection functions such as over-voltage protection, under-voltage protection, over-current protection, short-circuit protection, over-temperature protection, and low-temperature protection. It can issue alarm signals, implement local fault actions, and simultaneously report alarm information.

Fault diagnosis functions: The BMS can monitor the operating status of the battery in real time, diagnose abnormal operating conditions of the battery and the BMS itself, and upload alarm signals to the local monitoring system and power conversion system.

Operational management functions: The BMS enables effective management of charging and discharging, ensuring that overcharging and over-discharging do not occur during the process.

2.7.1. Main Interface

Master unit: When powered on, press the power button to release it, and the BMS will enter sleep mode.

Slave unit: Displays information about the battery pack where the slave unit is located.

Press the battery power button, the LCD screen lights on, enter the welcome interface, which lasts for 3 seconds, then enters the main interface.

Welcome interface:



Figure 2-4 Welcome interface

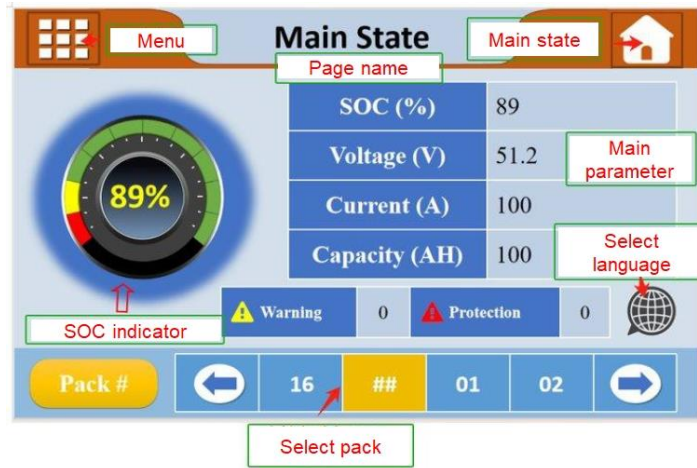





Figure 2-5 BMS display screen main state interface

The main state interface of the display screen allows users to view the system's current SOC status, voltage, current, capacity, as well as alarm and protection information.

When multiple battery packs are used in parallel, the master's main interface by default displays the average SOC, average voltage, total current, capacity, and alarm and protection information for the entire parallel battery system.

On the master display interface, users can toggle between displaying information for the entire system and information for the battery pack at the corresponding address by pressing the  or  keys. By flipping pages, users can view the real-time number of parallel battery packs.

Click the menu button  in the upper right corner to enter the unlock password permission confirmation interface.

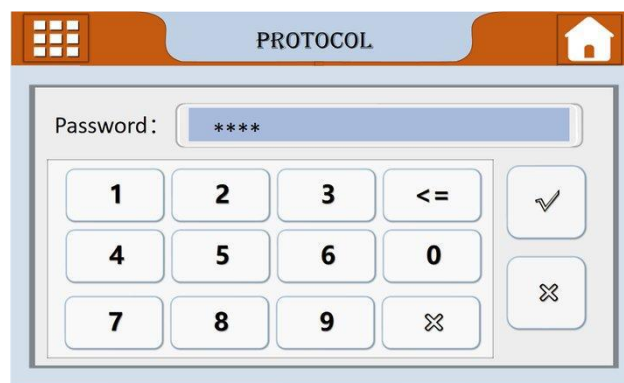

Figure 2-6 BMS Unlock Authorization Interface

Permissions are divided into three levels:

No permission: can browse the welcome interface and main status interface; restricted from viewing other cell details and fault alarm details.

Operator permission: can browse all interfaces and select language options; cannot set or modify protocols.

Administrator permission: can browse all interfaces, select language options, and set or modify protocols.

Protocol permission security: re-entering the protocol settings interface requires re-entering the administrator password. exiting the protocol interface will clear any entered passwords.

Note: Under normal circumstances, users should not require access to operator or administrator privileges.

2.7.2. Home Menu

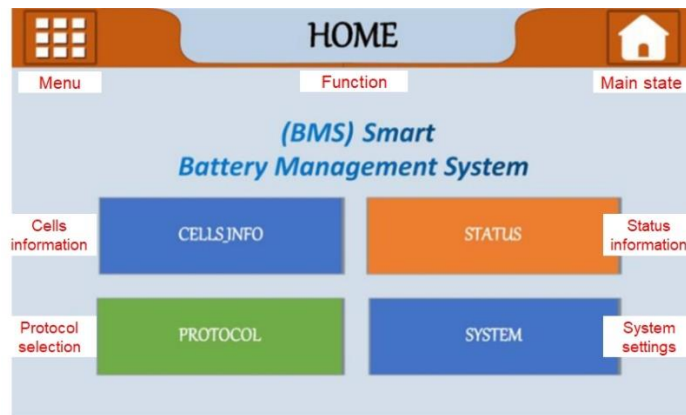

Figure 2-7 Home menu

Main menu interface mainly includes 4 sections: CELLS,INFO cell information interface, STATUS status data setting interface, PROTOCOL protocol selection interface, and SYSTEM system setting interface. you can return to the main status interface by pressing the main status button .

2.7.3. Cell Information Interface

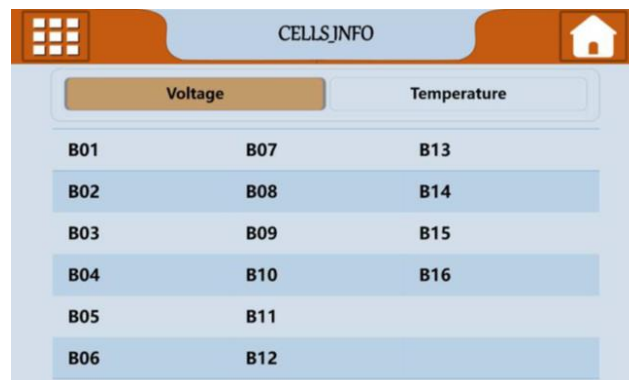



Figure2-8 Cell information interface

Cell information interface, can choose voltage and temperature, Voltage and temperature Temperature. View real-time cell voltage, cell temperature, MOS temperature, and ambient temperature information of the corresponding battery pack.

2.7.4. Protocol Selection Interface



Figure 2-9 Protocol selection interface

Protocol selection interface allows switching compatible inverter protocols, including RS485 and CAN protocols. The row with the dark blue background indicates the currently selected protocol. Use the up and down scroll buttons  and  to select a protocol. protocol switching requires entering administrator password (If required, please contact authorized personnel to obtain the password). Exiting the protocol interface activates the permissions. to modify the protocol again, re-authentication is required.

2.7.5. Status Information Interface

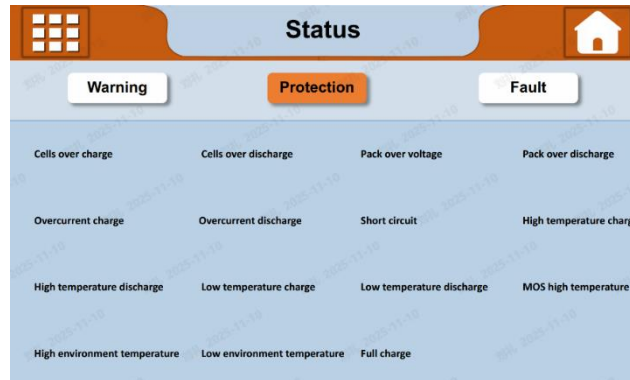





Figure 2-10 Status information interface

2.7.6. System Setting Interface



Figure 2-11 System setting interface

System setting interface allows viewing the LCD display version, BMS firmware version, PACK SN code, and Bluetooth SN code (if available) of the currently selected battery pack. Click , , or  to switch the corresponding language. Slave display can only view information related to the slave unit itself.

3. Blue tooth and Wi-Fi communication

3.1. APP Download

The BMS can communicate with a mobile APP via Bluetooth or Wi-Fi, enabling monitoring of various battery parameters including voltage, current, temperature, status, SOC, SOH, and production information.

The APP download QR code is as follows:

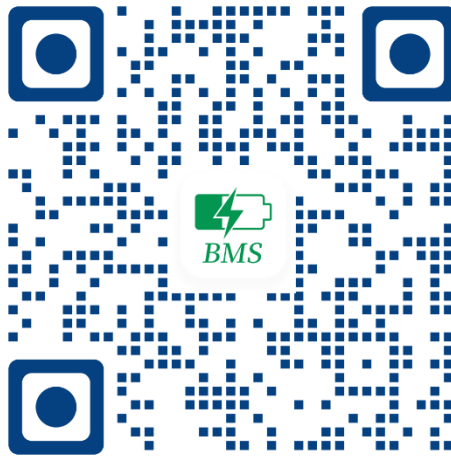

Notes:

1. iOS users can download the APP directly.
2. Android users with GMS (Google Mobile Services) support will be redirected to the Google Play Store for download.
3. Android users without GMS support must contact our company for assistance.

3.2. APP Dynamic Permissions

After installation, launch the APP. Upon first startup, it will actively request user confirmation and authorization for the following permissions:

1. Camera Permission: Used for scanning QR codes to add Wi-Fi devices during remote control.
2. Location Permission: Used for discovering nearby Bluetooth devices in local control and identifying current network information in remote control.
3. Device Status Information: For detecting device operational status.
4. Photos and Audio: Enables direct recognition of local photos in the scanning interface during remote control.

3.3. Control Methods

The APP supports two control methods: Local Control and Remote Control.

Local Control: Uses BLE Bluetooth communication to directly search for and connect one-to-one with nearby Bluetooth signals for device control. No account login or binding record is required, offering a ready-to-use experience. Connection can also be established by scanning the Bluetooth QR code on the battery pack.

Remote Control: Uses Wi-Fi communication, enabling device control from different geographical locations. Requires account registration/login and creates an account-device binding record. Network configuration is necessary.

Note: Bluetooth and Wi-Fi communications are mutually exclusive. After Wi-Fi binding, a successful unbinding is required before switching back to Bluetooth communication.

3.4. Local Control (BLE)

When the device is in a ready-for-network-configuration state, click the "Local Control" button. The device can be found on the local control page; select it to enter the device control page.

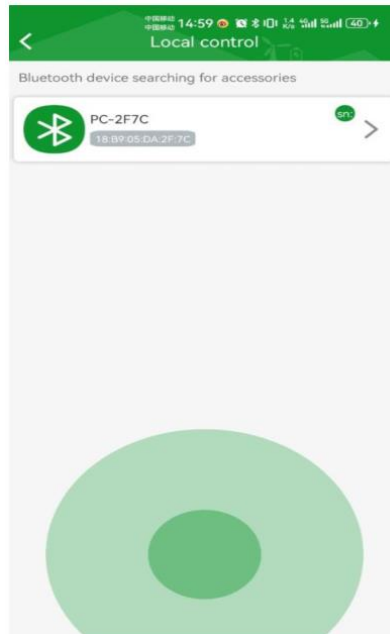

3.5. Remote Control (Wi-Fi)

3.5.1. Account Registration and Login

Registration: New accounts are created using an email address, password, and verification code.

Note: For new accounts, selecting the actual country/region is crucial. Once set and created successfully, devices added through this account will automatically connect to the server node consistent with the account's region.

Login: Use the registered email and password to log in.

Forgot Password: Passwords can be reset via the registered email address.

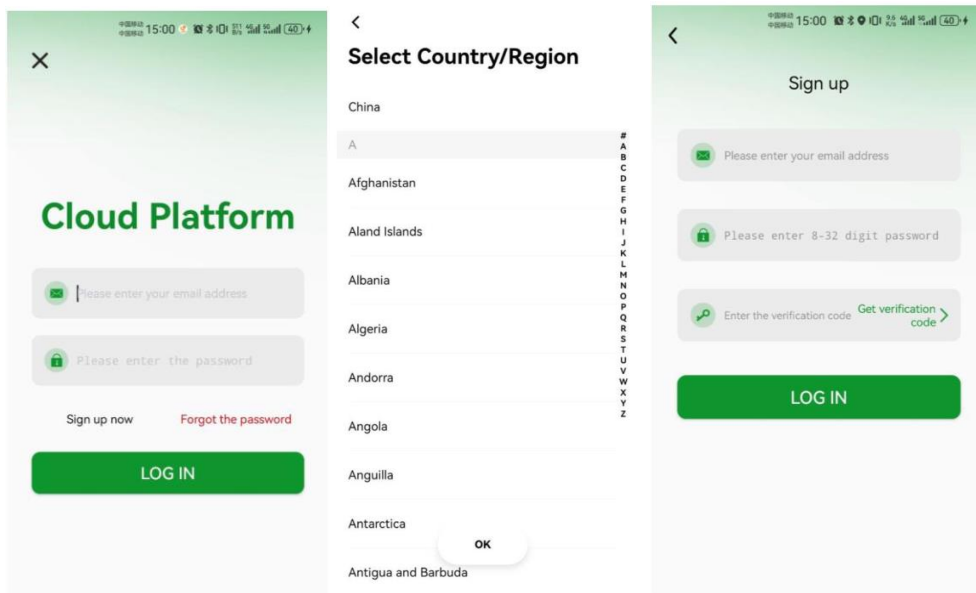

3.5.2. Device List

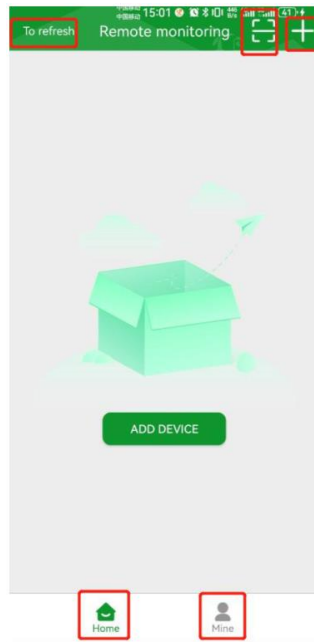

3.5.3. Adding a Device

1、 Restore Wi-Fi Module to Factory Settings

Restoring the Wi-Fi module to factory settings makes the device discoverable. Press and hold the reset button until a buzzer sounds, then continue holding for 5-15 seconds.

Note: The prompt sound occurs only after holding for about 13 seconds. The action will not trigger if held for less than 13 seconds or more than 30 seconds.

2、 Click "Add" or "+" to enter the search page and search for devices.

Note: This step requires the phone's "Bluetooth", "Location", and "Wi-Fi" functions to be enabled. Otherwise, the search and subsequent network configuration cannot be completed.

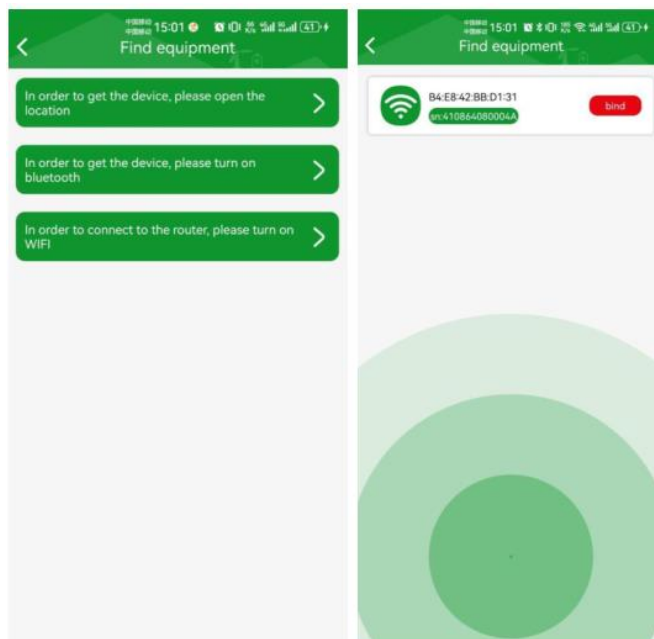

3、 Enter Network Configuration Information

Click the device discovered in the previous step to jump to the network configuration page. Enter the Wi-Fi name (SSID) and password for the device to connect to. The Wi-Fi network can

also be changed. After confirming the password is correct, click "Next" to enter the configuration waiting page.

Note: The phone must be connected to the target Wi-Fi first. The module only supports 2.4GHz Wi-Fi; please verify this accordingly.

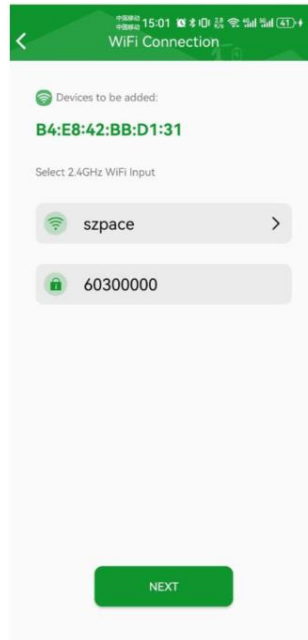

4、Execute Network Configuration

The APP and device will automatically execute the "Connect Device", "Configure Network", "Device Cloud Connection", and "Bind Device" procedures. Please wait patiently.

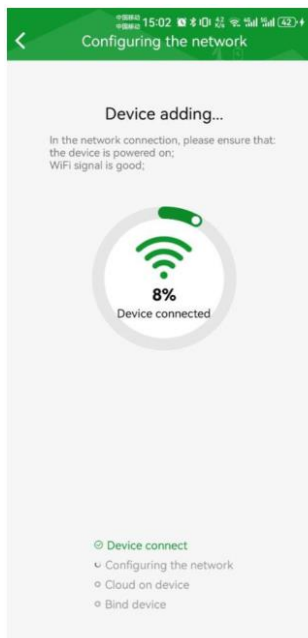

5、Configuration Result

Upon completion, the page will jump to the result screen. Click "Save" to successfully add the device and automatically return to the device list page. If configuration fails, follow the APP prompt information, check the steps, and restart from step "1. Restore Wi-Fi Module to Factory Settings". If failures persist after multiple attempts, save the error page and contact our support staff.

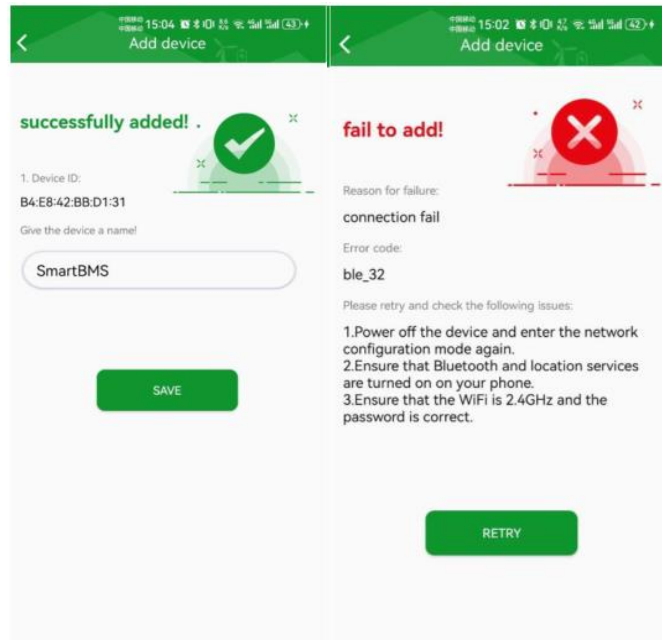

6、 Device Editing

Long-press a device entry to open an edit menu at the bottom.

Rename: Modify the device name for easier identification.

Delete: Unbinds the device from the account. Re-adding via scanning or network configuration is required for next use.

7、 Device Sharing

Long-press a device entry. If you are the device administrator (the account that first bound the device via configuration), you can generate a QR code for the device, allowing other users to scan and add it.

Note: Non-administrators cannot re-share. Each generated QR code can only be scanned once and is valid for a limited time (30 minutes).

8、 OTA Upgrade

When a new firmware version is available in the backend, clicking on a specific device in the APP will trigger a pop-up upgrade prompt. Click "Upgrade Now" to proceed with the firmware update. Click "Remind Me Later" to enter the device parameter display and settings pages normally.

9、 Account Logout and Deletion

Account Logout: Allows switching to another account for login and use.

Account Deletion: Once deleted, all account information and binding relationships will be permanently erased. Re-registration is required for future use.

4. Product Installation

4.1. Installation Flow Chat

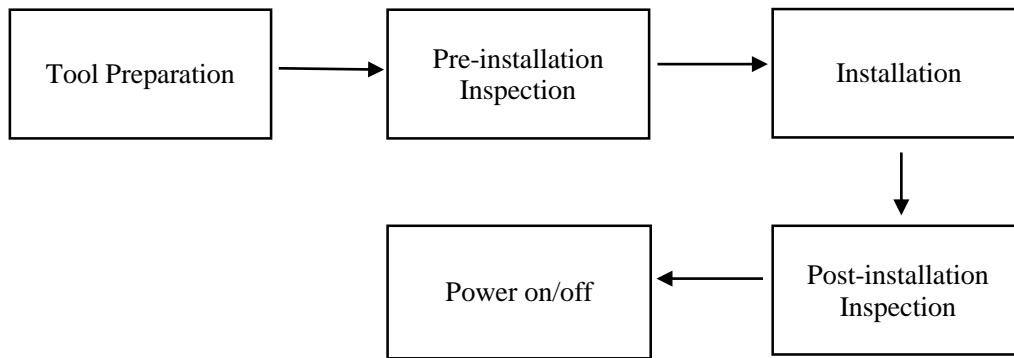

Figure 4-1 Installation Flow Chat

4.2. Tool Preparation

The main tools required for installing this product are as follows:

- Personal protective equipment, such as safety shoes, safety glasses, insulated gloves, etc.
- Screwdriver set
- Socket wrench kit or adjustable wrench
- Electric drill
- Basic electrical tools, including wire cutters, wire strippers, crimping pliers, etc.

Due to varying on-site conditions, installers and users should prepare any additional tools not listed here based on actual requirements.

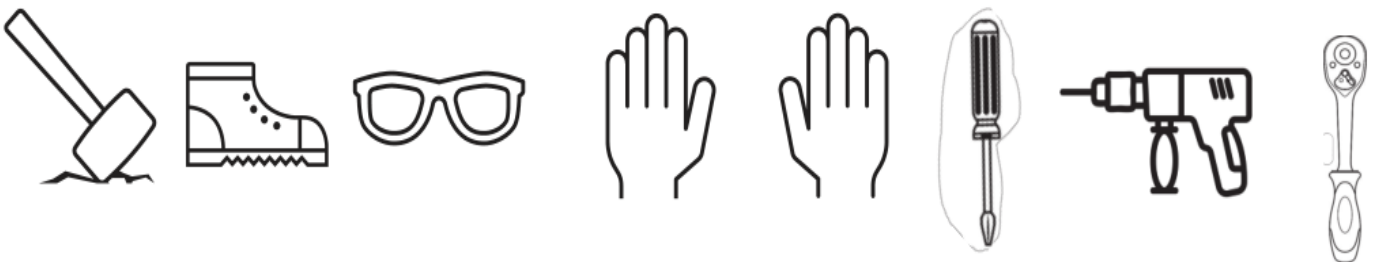

4.3. Pre-installation Check

4.3.1. Packing List

Table 4-1 Packing list (per battery pack)

No.	Item	Quantity	Remark
1	CoreX 5 Elite battery pack	1	
2	Wall-mounted bracket	1	
3	Expansion bolts	4	
4	Rubber feet with bolts	4	
5	White U-shaped metal edge protection strip	1	0.6m
6	Positive output power cable	1	
7	Negative output power cable	1	
8	Positive parallel power cable	1	
9	Negative parallel power cable	1	
10	Pack-Inverter communication cable	1	
11	Pack parallel communication cable	1	
12	Product factory test report	/	
13	Product certificate	/	
14	User manual	/	

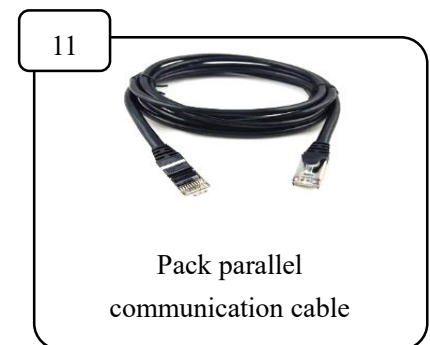
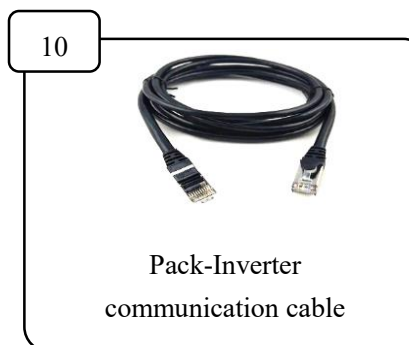
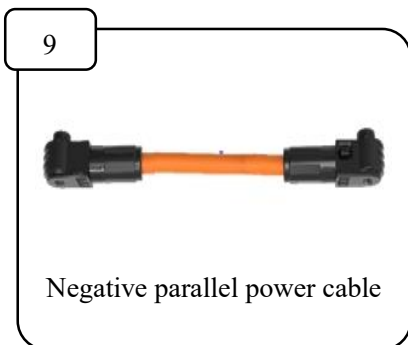
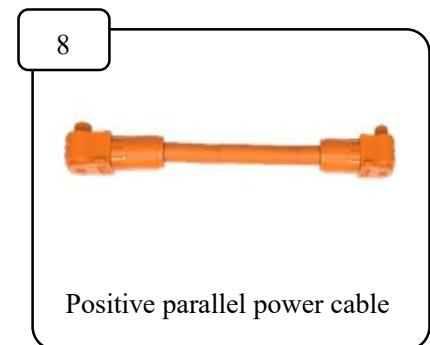
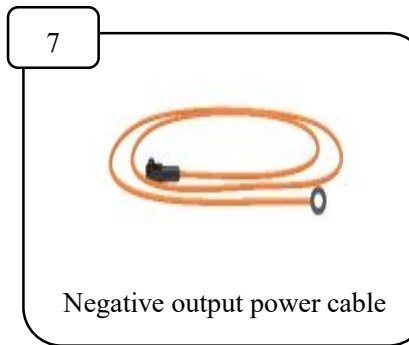
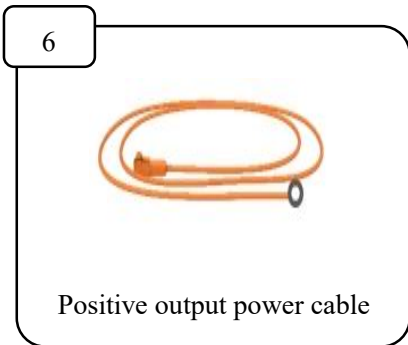
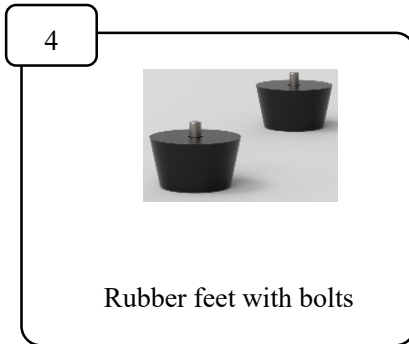
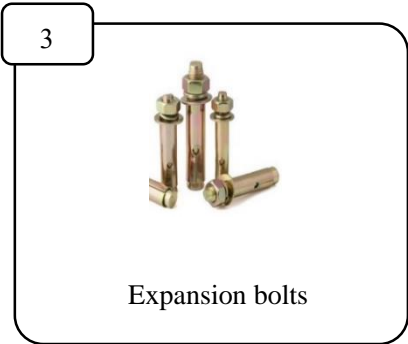

4.3.2. Unpacking Inspection

- Inspect the packaging to ensure it is intact without dents or damage.
- Check whether the quantity of each item in the packing list is consistent with the actual item.
- Examine the product's exterior to ensure there are no deformations, paint chips, loose bolts, or other abnormalities.
- Inspect the product's output interfaces; the positive and negative terminals, as well as low-voltage output ports, should be clean, free from dirt, liquid, or corrosion.
- Check the wiring harnesses: all high and low voltage cables should have intact insulation; interfaces should be clean and free from dirt, liquid, or corrosion; power cable connectors and low-voltage harness terminals should be secure and free from looseness.

4.3.3. Preparations

- Space: Place the battery pack on a clean, stable surface, ensuring the terminals do not come into contact with conductive materials.

4.3.4. Power-On/Power-Off Check

- Power on/off check: Press the power button to turn on the device, check the LED lights to confirm the product status is normal, then press the power button again to turn off the device.

4.3.5. Important Notes

- This product must be installed indoors or in a professional rain shelter.

4.4. Installation

Installation Location Requirements: The installation location shall be solid brick-concrete structures, concrete walls, and floors. If other types of walls or floors are selected, they must be constructed of flame-retardant materials and meet the equipment load-bearing requirements (each battery pack weighs approximately 48kg).

Space Requirements: When installing the energy storage system, ensure no other equipment (except SUNGOLDPOWER related equipment and sunshades) or flammable/explosive materials are nearby. Sufficient space must be reserved to meet installation, heat dissipation, and safety isolation requirements. In wall-mounted configurations, no objects are permitted to be placed beneath the unit.

4.4.1. Battery Pack Installation

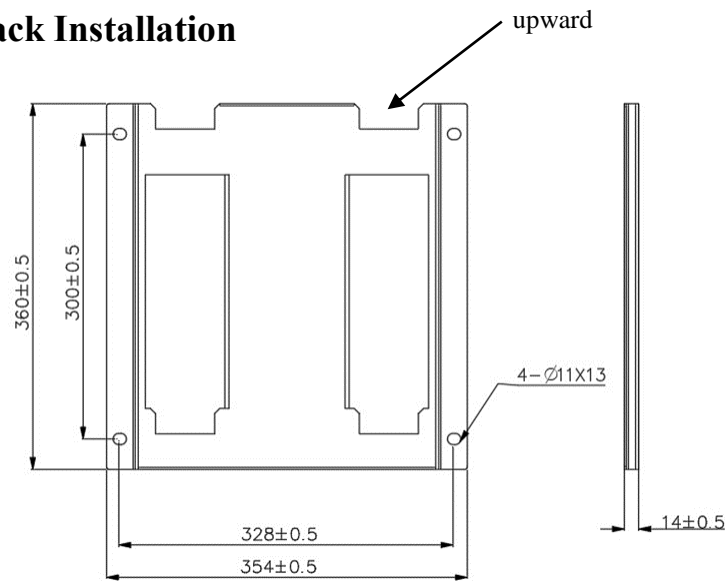

Figure 4-2 Illustration of wall-mounted bracket

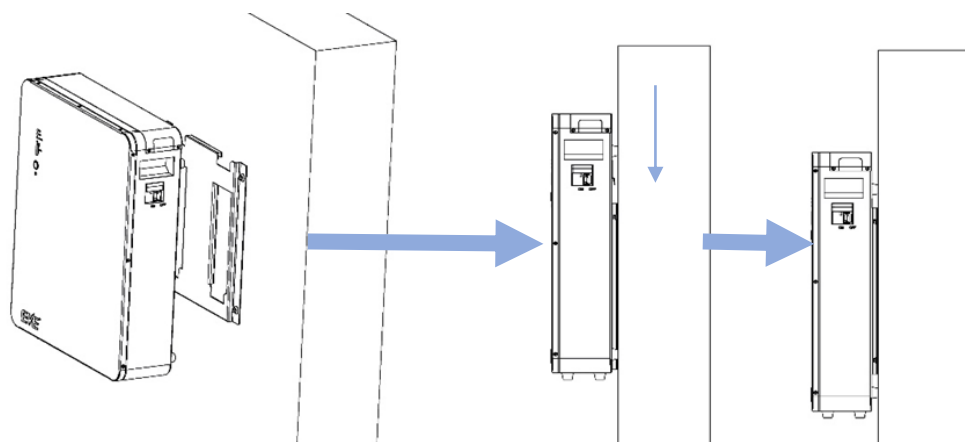

Figure 4-3 Installation of wall-mounted battery pack

- a) Select a sturdy wall to install the wall-mounted bracket.
- b) The dimensions of the wall-mounting bracket are as shown in the diagram above. Position the bracket against the wall in the indicated orientation, ensuring the bottom edge remains parallel to the floor.

- c) The horizontal spacing between wall-mounted installation holes is 328 mm, and the vertical spacing is 300 mm. Referring to the diagram above, use a marker pen to mark the drilling positions.
- d) Use an impact drill to bore holes at the marked positions (hole diameter: 14mm, depth: ≥ 60 mm).
- e) Install the wall-mounted bracket and secure it with expansion bolts, applying a torque of 12 N m.
- f) Lift the bottom of the battery pack parallel to the ground and hang it from the top of the wall-mounted bracket.
- g) Confirm the battery pack is securely installed.

4.4.2. Connection of Power Cable

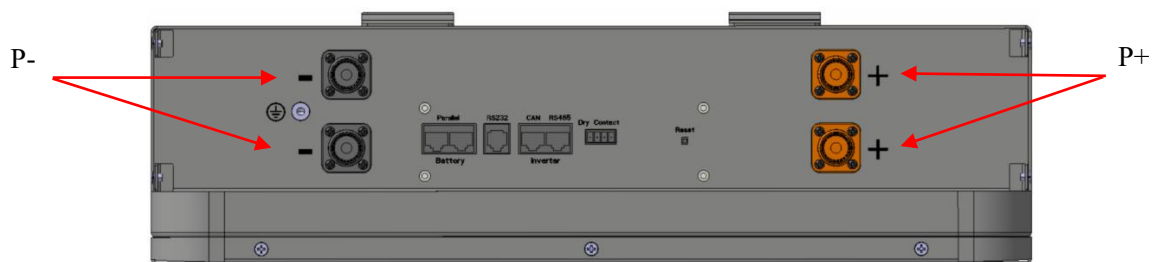

Figure 4-4 Schematic diagram of cable interface (top view)

Use the negative output power cable to connect the battery pack negative (-) terminal to the inverter (P-), and the positive output power cable to connect the battery pack positive (+) terminal to the inverter (P+): Simply insert the quick-connect plugs at both ends of the power cables into the corresponding sockets. Ensure the connector colors match the socket colors to avoid incorrect or reversed connections.

4.4.3. Connection of Communication Cable

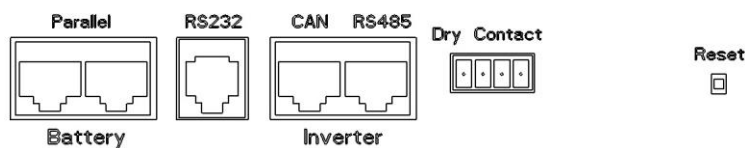

Figure 4-5 Communication interface diagram

A single battery pack can use either CAN or RS485 communication. Connect the inverter communication port to the corresponding communication port on the battery pack using the battery pack-inverter communication cable.

Note: The communication cables listed as items 10 and 11 in the packing list are both standard 8-pin straight-through Ethernet cables. When connecting to the inverter, ensure the pinout definitions correspond correctly. If they do not match, crimp the communication cable according to the compatible inverter communication port definition and the pinout table in section 2.4 of this user manual.

4.4.4. Grounding

- a) After assembly of the battery packs, grounding installation must be performed to ensure safety during use. Secure the grounding wire using the M5*12 grounding screw with a torque of 3.5N m.
- b) Connect the battery pack's grounding point to the grounding network using a wire.

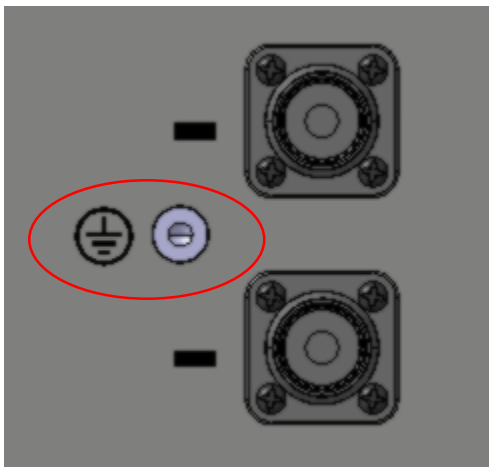

Figure 4-6 schematic diagram of grounding points

4.4.5. Battery Pack Parallel Connection

- When the maximum system current is 100A or below, there are two parallel connection methods; either of which can be selected:

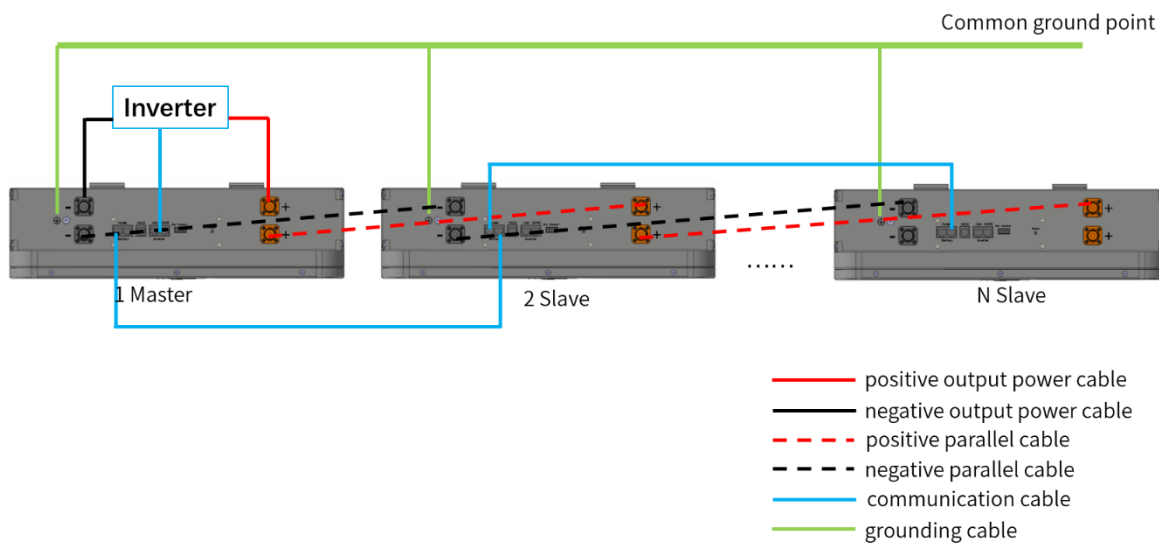

Figure 4-7 Battery Pack Parallel Power and Communication Cable Wiring Diagram – Option 1 (≤100A)

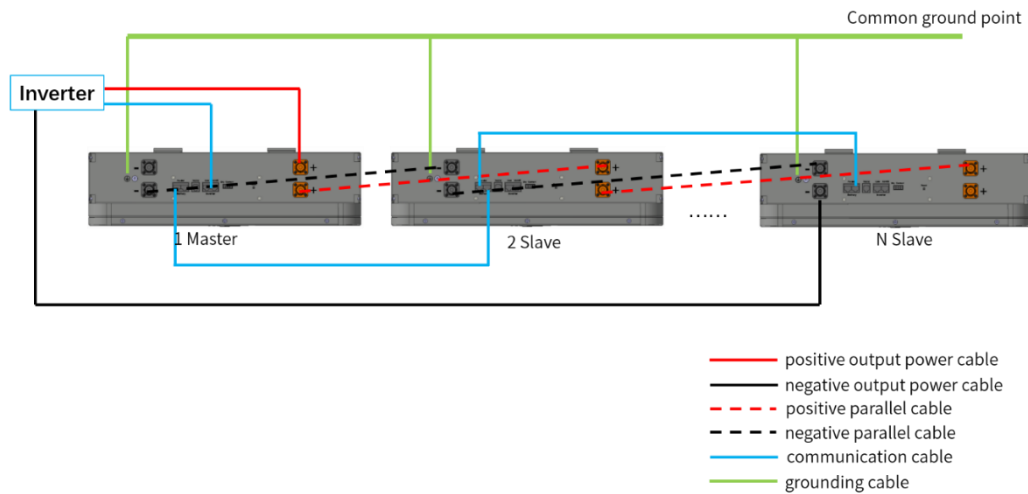

Figure 4-8 Battery Pack Parallel Power and Communication Cable Wiring Diagram – Option 2 ($\leq 100A$)

- a) Installation of battery packs follows the methods described earlier.
 - b) When multiple battery packs are connected in parallel, the distance between adjacent packs should be no less than 10 cm.
 - c) For parallel connection of multiple battery packs, power and communication cables should be connected to the inverter as shown in the diagram above.
 - d) The maximum allowable charge/discharge current for the battery system in parallel configuration is 100A.
 - e) If the actual current exceeds 100A, the parallel connection method must be changed. A busbar method should be used for parallel connection.
 - f) Communication cables should be connected from the inverter's communication port to the parallel input port of Battery Pack 1. The parallel output port of Battery Pack 1 should then be connected to the parallel input port of Battery Pack 2, and continue in this manner, with up to 15 battery packs can be connected in parallel.
- **The parallel connection wiring method is as follows when the system maximum current is over 100A.**

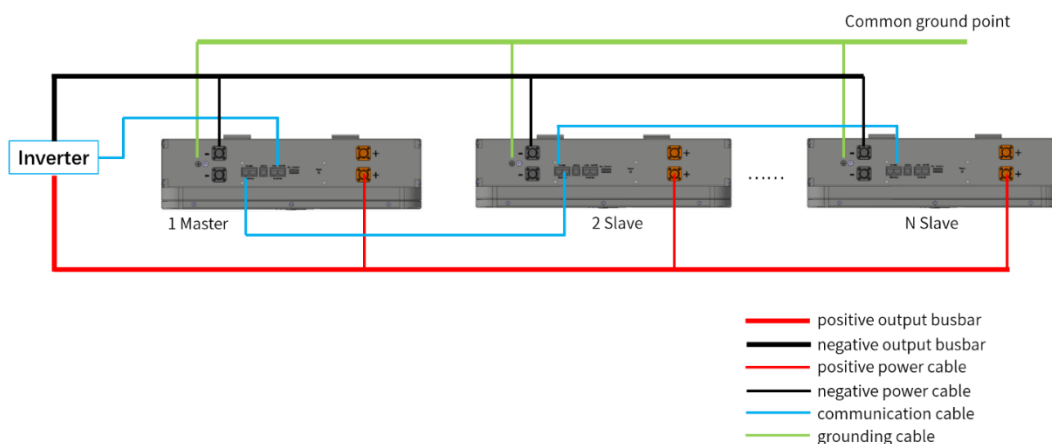

Figure 4-9 Battery pack parallel power cable and communication cable wiring diagram ($> 100A$)

4.5. Post-installation Inspection

No.	Item	Standards
1	Environment	Installation space should facilitate ventilation and heat dissipation, with a clean and tidy environment and appropriate temperature and humidity.
2	Appearance	The product appearance should be intact, without damage, rust, or paint peeling. All nameplates and labels should be clear and complete.
3	Installation	The equipment should be securely installed.
4	Connection	Power and communication cables should be correctly and reliably connected. The ground wire should be well connected to the grounding network, with the grounding point free of debris, damage, or corrosion.
5	Electric	The circuit breaker status is ON, and the button switch is in the OFF position to allow for the next step of insulation testing.
6	Insulation	Before debugging, ensure: the system is powered off. Use the insulation meter set to DC500V range. Clamp the black negative probe of the insulation meter to the battery pack grounding bolt, and sequentially contact the red positive probe to the battery pack's positive terminal (P+) and negative terminal (P-). After each contact with the test point, press the insulation meter's test button to begin testing. Test for 5 seconds, with an insulation resistance value $\geq 1000\Omega/V$.

4.6. System Power On/Off

4.6.1. System Power On

When powering on the battery pack, follow the sequence below to prevent damage.

For Single Unit Operation: After verifying the wiring connections between the battery pack and the inverter are correct, press the power button on the battery pack's front panel. The LED indicators will light up sequentially, indicating the startup process is complete.

For Multiple Battery Packs in Parallel: First, connect all parallel power cables and communication cables between the battery packs, ensuring the master unit is properly connected to the inverter via both power and communication cables. After confirming all connections are correct, press the power button on the master unit. Once the master unit has fully started up and all its panel LEDs display normally, press the power buttons on the front panels of Slave 1, Slave 2, and Slave 3 in sequence. The LED indicators on all battery packs will then light up sequentially, indicating the system startup is complete.

Confirm the battery pack status indicators are normal.

Note: After power-on, the system typically stabilizes and provides output within 5 seconds.

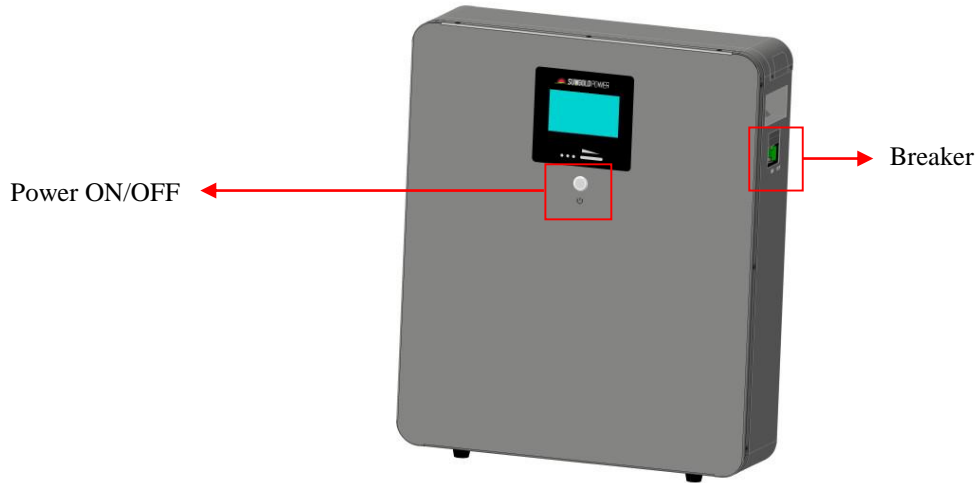

Figure 4-8 Power Button (Front Panel)

4.6.2. System Power Off

When shutting down the battery system, follow the procedure below to prevent damage to the battery packs:

For a single battery pack in standalone operation: Turn off the power button on the front panel (the panel LEDs will turn off), then disconnect the external power cables and communication cables from the battery pack. The shutdown is now complete.

For multiple battery packs in parallel operation: First, disconnect the external power cables and communication cables from the battery packs. Then, sequentially press the power buttons on the front panels of the Master unit, Slave 1, Slave 2, and Slave 3. The LED indicators on the battery packs will turn off in sequence, indicating the system shutdown is complete.

Confirm that all battery pack status indicators have turned off.

4.6.3. Sleep and Wake-up

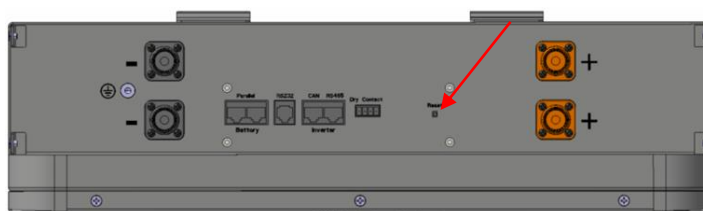

Figure 4-9 RESET Button (Front Panel)

When powered on, press and hold the reset button on the front panel for 3-6 seconds. The BMS will enter sleep mode, indicated by the LED indicators illuminating sequentially from the lowest power level for 0.5 second each, and the battery pack will enter the dormant state.

When the battery pack is in sleep mode: Press and hold the Reset button for 3-6 seconds then release. The BMS is activated, indicated by the LED indicators lighting up sequentially starting from the "RUN" indicator for 0.5 second each. The battery pack enters the working state.

When the BMS is active, press and hold the front panel reset button for 6-10 seconds. The BMS will be reset, indicated by all LED lights illuminating simultaneously for 1.5 seconds, and the battery pack will enter standby mode.

5. Instruction

- a) Please carefully read the product specification before use.
- b) Do not strike, throw, or trample the battery pack.
- c) Do not short-circuit the battery pack.
- d) The battery pack must avoid contact with corrosive substances.
- e) Do not immerse the battery pack in water.
- f) Reverse charging or discharging is prohibited.
- g) The battery pack must be used within the specified environmental conditions. Excessively high or low ambient temperatures will affect battery performance and safety.
- h) The battery pack must be used and stored in a clean, well-ventilated environment, kept away from fire and heat sources. Do not use or store it in direct sunlight.
- i) If corrosion, unusual odors, or other abnormalities are detected during the initial use of the battery pack, stop using it immediately.
- j) The battery pack can be used individually or in parallel with multiple units (but not in series). The number of battery packs connected in parallel must not exceed 15.
- k) The battery pack must be used within the specified charge rate or power conditions. The maximum charge voltage must not exceed the product's technical requirements to prevent overcharging, which could impair the battery's electrical, mechanical, and safety performance.
- l) The battery pack is prohibited from being used or stored in areas with strong electrostatic or electromagnetic fields to prevent potential safety hazards.
- m) The battery pack must be installed and stored in its designed upright position. Placing it on its side or upside down is strictly prohibited.
- n) Do not disassemble, reassemble, or modify this product without our company's authorization.
- o) The battery pack must be used in strict accordance with the above requirements. Failure to do so will void the warranty, and our company shall not be held liable for any resulting property damage or safety incidents.

6. Fault and Emergency Handling

6.1. Common Fault Handling

No.	Fault Phenomenon	Fault Analysis	Solution
1	Communication Fault	RS485/CAN communication failure	1. Check communication cables. 2. Restart the battery pack and PCS. If the issue persists, please power off the battery and contact our authorized personnel for assistance.
2	Single pack overcurrent	/	Check if the battery pack output port is short-circuited. If no abnormality is found, please power off the battery and contact our authorized personnel for assistance.
3	Over-current occurs during multi-battery pack parallel operation.	System output port short-circuit or battery pack circuit breaker not closed	Check if the battery pack output port is short-circuited. If the battery pack circuit breaker is not closed, confirm whether it was tripped due to abnormal protection. If not abnormal, manually close the circuit breaker.
4	Protection Fault	Overvoltage protection	Wait for protection to reset, or restart the battery pack and PCS. If the issue persists, please power off the battery and contact our authorized personnel for assistance.
		Undervoltage protection	
		Short circuit, reverse connection, or failure protection	
		Temperature abnormality (low/high temperature)	Power off and wait 2 hours for temperature to normalize, then restart. If the issue persists, please power off the battery and contact our authorized personnel for assistance.
5	Protection Failure	System protection failure or other issues requiring emergency power cut-off	Please power off the battery and contact our authorized personnel for assistance.
6	Rapid current/temperature rise	Battery overcurrent, overcharging, or short circuit	Wear insulated gloves, disconnect all switches, and quickly remove all power cables. Please power off the battery and contact our authorized personnel for assistance.
7	Smoke or fire	Battery short circuit	Wear insulated gloves, disconnect all switches. For minor smoke or fire, use a fire extinguisher. For major fires, follow emergency procedures.
8	Insulation Fault	System leakage	Stop use immediately and power off the battery and contact our authorized personnel for assistance.
9	Flashing LED during parallel use	Parallel connection failure	Restart the master unit. If the issue persists, please power off the battery and contact our authorized personnel for assistance.

6.2. Emergency Handling

The battery pack equips multiple layers of protection and offers high safety under normal operating conditions. However, in the event of accidents or failures caused by external factors, appropriate measures should be taken promptly while ensuring personal safety:

If the battery pack is dropped or severely impacted

- Move the battery pack to an open, safe area to avoid affecting nearby units. If significant odor, damage, smoke, or fire is observed, evacuate immediately, call emergency services, and contact professionals. Professionals should use firefighting equipment to extinguish fires safely.

In case of fire:

- Evacuate the building or equipment area immediately. Call the fire department and notify professionals.
- Provide necessary product information to firefighters and professionals, including but not limited to: battery pack type, capacity, location, etc.
- Under no circumstances should anyone re-enter the burning building or equipment area.
- Isolate the area and prevent unauthorized personnel from approaching.
- If safe to do so, power down the battery pack or system via the inverter or by disconnecting the main switch.
- After firefighters confirm the fire is extinguished, professionals should perform further harmless disposal.



CONTACT US

(833)761-6080

support@sungoldpower.com