

Rechargeable Lithium battery

Operation and Maintenance manual



Product Model: SG48200T

Product Specifications: 51.2V 200Ah

Content

1. Information	1
1.1 Validity	1
1.2 Target Group	1
1.3 Levels of warning messages	1
1.4 Symbol Description	2
1.5 Abbreviation Description.....	3
2. Safety	5
2.1 Safety precautions.....	5
2.2 Safety instructions	6
2.2.1 Safety gear.....	6
2.2.2 Emergency safety measures.....	6
2.2.3 Other Tips.....	7
3.1 Introduction.....	8
3.2 Features.....	9
3.3 Specification.....	10
3.3.1 Dimension.....	10
3.3.2 Parameters.....	10
3.3.3 Panel Interface.....	11
3.4 Protection function.....	15
4 Installation	17
4.1 Preparation	17
4.1.1 Safety Compliance.....	17
4.1.2 Environment.....	17
4.1.3 Tools	17
4.2 Inspection	19
4.2.1 Unpacking.....	19
4.2.2 Scope of delivery.....	19
4.3 Start Installation	21
4.3.1 Remainder	21
4.3.2 Procedures	22
4.3.3 Tips.....	23
5. Cable connection and commissioning	24
5.1 Get battery ready.....	24
5.2 Grounding cable connection	24
5.3 Communication cable connection	24
5.4 DC power cable connection	25
5.5 Connecting with inverter.....	25
5.6 Commissioning	28
5.7 Switch off battery	29
5.7.3 Turn off all batteries signal switch.....	29
6 Troubleshooting and FAQ	30
7. Transport, Storage	33

8. Disposal of battery 34
Appendix I 35

1. Information

1.1 Validity

This document is valid for: SG48200T Battery Pack.

1.2 Target Group

This document is intended for qualified persons and operators. Only qualified persons are allowed to perform the activities marked in this document with a warning symbol and the caption "Qualified person".

Qualified persons must have the following skills:

- Knowledge of how lithium iron phosphate batteries work and are operated.
- Knowledge of how an energy storage system (including PV/battery/hybrid inverter, MPPT, Meter, Distribution box etc.) works and is operated.
- Knowledge of local applicable connection requirements, standards, and directives.
- Training in the installation and commissioning of electrical devices, batteries.
- Training in how to deal with the dangers and risks associated with installing, repairing and using electrical devices, batteries.

1.3 Levels of warning messages

The following levels of warning messages may occur when handling the product

⚠ DANGER

Indicates a hazardous situation which, if not avoided, will result in death or serious injury.

⚠ WARNING

Indicates a hazardous situation which, if not avoided, could result in death or serious injury.

⚠ CAUTION



Indicates a hazardous situation which, if not avoided, could result in minor or moderate injury or product permanent damage.





⚠ NOTICE

Indicates a situation which, if not avoided, can result in property damage or product not work or accelerated product damage



1.3 Symbol Description

1.4.1 Symbols on products label

Label	Definition
	Beware of electrical shock
	Do not place the battery within children/pet touchable area.
	Do not place the battery near heat source and flammable material

	Do not expose the battery to direct sunlight, rain and snow.
	Do not short circuit the battery
	Recycle label
	WEEE designation

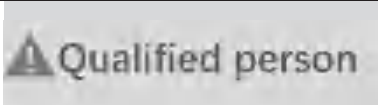
1.4.2 Other symbols

Label	Definition
	Indicates activities that can only be performed by qualified persons
	Grounding point

1.5 Abbreviation Description

Abbreviation	Definition
Battery/battery pack/battery module	Single SG48200T rechargeable lithium iron phosphate battery pack including cells, BMS and enclosure etc.
Battery system/cluster	Multiple SG48200T battery pack connected in parallel with power, communication and grounding cables and installation auxiliaries.
BMS	Battery management system Electronical Unit to ensure lithium cells' safety and display information or control the battery work mode.
SOC	State of charge The battery state of charge refers to the percentage of the

	remaining capacity and rated capacity of the battery.
SOH	State of health The battery health status refers to the percentage between the full charged capacity and the rated capacity of the battery.
DIP switch	Dual in-line package switch
COCP	Charge over current protection
DOCP	Discharge over current protection
COVP	Cell over voltage protection
POVP	Pack over voltage protection
CHTP	Charge high temperature protection
DHTP	Discharge high temperature protection
CUVP	Cell under voltage protection
PUVP	Pack under voltage protection
CLTP	Charge low temperature protection
DLTP	Discharge low temperature protection
SCP	Short circuit protection
LCD	Liquid Crystal Display

2. Safety

2.1 Safety precautions

DANGER

Explosion risk

- Do not impact the battery with heavy objects.
- Do not squeeze or pierce the battery pack.
- Do not throw the battery pack into the fire.

WARNING

Fire risk

- Do not expose the battery pack to the condition over 80°C.
- Do not put the battery near a heat source, such as a fireplace.
- Do not expose the battery pack to direct sunlight or raining.

CAUTION

Electric shock risk

- Do not allow non-qualified person to disassemble the battery pack.
- Do not touch the battery pack with wet hands.
- Do not expose the battery pack to moisture or liquid environment.

NOTICE

Damage risk

- Do not short-circuit or reverse connect the battery.
- Do not use chargers or charging devices unapproved by the manufacturer to charge the battery.
- Do not mix batteries from different manufacturers or different kinds, types or brands.

2.2 Safety instructions

The battery has been designed and tested in accordance with international (such as UN38.3 etc.) safety requirements. However, due to various factors during the whole lifetime process, Manufacturer cannot guarantee absolute safety, in order to prevent personal injury and property damage and ensure long-term operation of the battery, please do read the below section carefully to operate the battery and handle emergency situations.

2.2.1 Safety gear

It is required to wear the following safety gear when installing and handling the battery pack.



Insulated gloves



Safety Glasses



Safety Shoes

2.2.2 Emergency safety measures

Water invasion

Please cut off the AC power supply of the system first and then disconnect all switched under the premise of ensuring safety.

Electrolyte or gas leakage

If the battery pack leaks electrolyte, avoid contact with the leaking liquid or gas. If one is exposed to the leaked substance, immediately perform the actions described below.

- Gas Inhalation: Evacuate the people in the contaminated area and seek medical aid immediately.

- Eye Contact: Flush your eye with clean and flowing water for 15 min, and seek medical aid immediately.
- Skin Contact: Thoroughly rinse the exposed area with soap and water to be sure no chemical or soap is left on them, and seek medical aid immediately.
- Ingestion: Induce vomiting, and seek medical help immediately.

WARNING

In case of fire situations, please use carbon dioxide fire extinguisher rather than liquid to put out fires.

2.2.3 Other Tips

- All the product are strictly inspected before shipment, please contact your supplier for replacement if you notice there's any defectives such as swelling.
- Do not disassemble batteries and components, otherwise the manufacturer will not be responsible for any damage caused by unauthorized disassembly or repair.
- Do enable the battery to be safely grounded before use to make sure the system in safe and normal operation.
- Please ensure that the electric parameters of these devices are compatible mutually before connecting the battery to other devices.
- Please take the environmental factors into careful considerations to ensure that the system can work in a suitable condition as the environment and storage methods have a certain impact on the service life and reliability of this product.

3. Product Overview

3.1 Introduction

The SG48200T battery is designed for residential application and works as a storage unit in the photovoltaic system. It is a 51.2V lithium battery system, with BMS inside. It could be operated in both on-grid, back-up and off-grid modes with compatible inverters. Below is the general schematic of an ac-coupled system with the batteries.

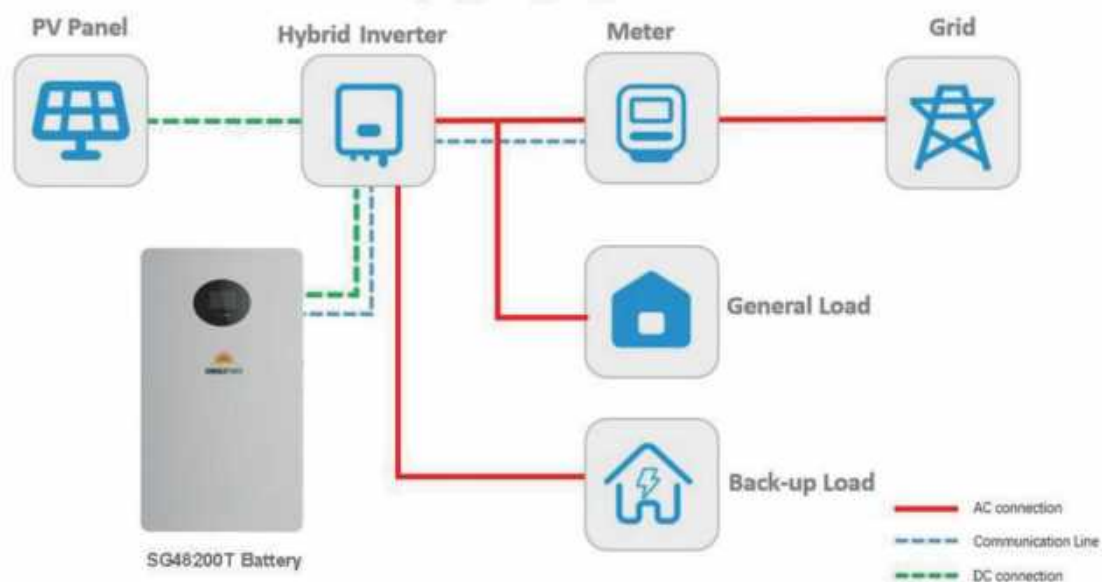

⚠ CAUTION

The electrical connections in this diagram are for illustration purposes only. Please follow the recommendations in the relevant equipment manual and operate by personnel with professional qualifications.

3.2 Features

- Highest safety, battery is made from LiFePO₄ chemistry and comply with highest international safety and transport standard.
- Modular and flexible, support up to 32 batteries connect together to expand the system energy.
- Built-in pre-charge circuit to avoid rush current when connecting with different inverter/chargers.
- Automatic dynamic addressing function when connected multiple batteries together.
- Support a maximum of 96% DOD under off-grid and back-up application
- Built in BMS provide warning and protection functions including over-discharged, over-charged, over-current, short-circuit and high/low temperature.
- LiFePO₄ as cathode material and automatic balancing function to meet longer cycle life
- Compact size and light weight for easy installation and maintenance.
- Multiple installation bracket (optional) to adopt with different customers' requirement.
- LED display, CAN/RS485 port for external communication and upgrade the BMS firmware.
- Rapid shut down function for North American market.
- Equipped with LCD to view battery information.

3.3 Specification

3.3.1 Dimension

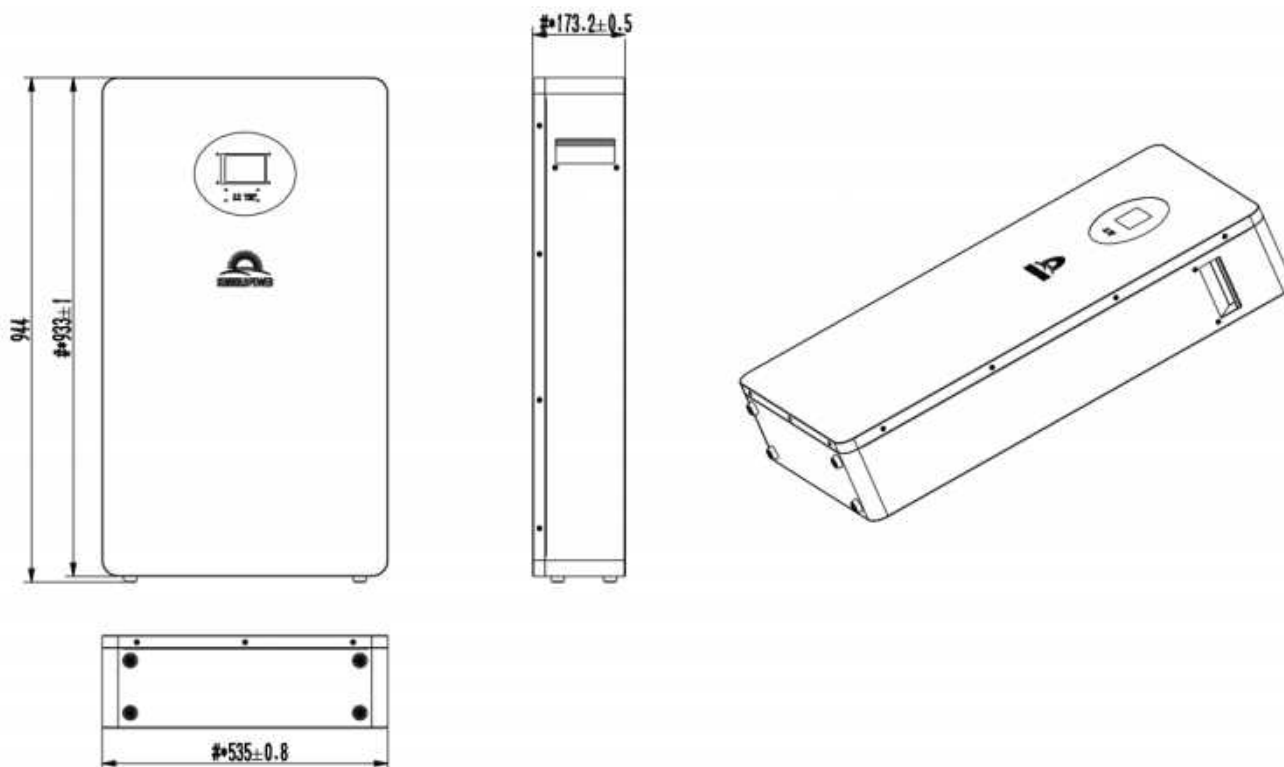

3.3.2 Parameters

Items	SG48200T
Rated voltage	51.2V
Max. voltage range	44.8~57.6V, Shipping voltage>51.2V
Charge voltage	56.0V
Float charge voltage	54.6V
Nominal energy@0.5c	10.24KWh
Usable energy@0.5c	9.84kWh
Nominal capacity@0.5c	200Ah
Dimension	535*944*173mm
Weight	~90kg
Standard charge current	≤100A
Max. charge current	140A
Standard discharge current	≤100A

Max. discharge current	200A (initial temp. $\leq 86^{\circ}\text{F}$ (30°C))	
Peak discharge current	200~240A@5mins 240~300A@15S	
Communication	RS485 /CAN	
Max parallel number	32pcs	
Operation temperature ¹	Charge: $0\sim 50^{\circ}\text{C}$ Discharge: $-10\sim 50^{\circ}\text{C}$	
Storage temperature @off mode	$32^{\circ}\text{F}(0^{\circ}\text{C}) < T < 86^{\circ}\text{F}(30^{\circ}\text{C})$	< 6 months
	$14^{\circ}\text{F}(-10^{\circ}\text{C}) < T < 113^{\circ}\text{F}(45^{\circ}\text{C})$	< 3 months
	Recommended environment	59°F to 95°F ($15\sim 35^{\circ}\text{C}$), 5~75%RH

⚠ NOTICE

The optimum operating temperature range is from 15°C to 30°C , Frequent exposure to the harsh temperatures may worsen the performance of the battery pack and cycle life.

3.3.3 Panel Interface

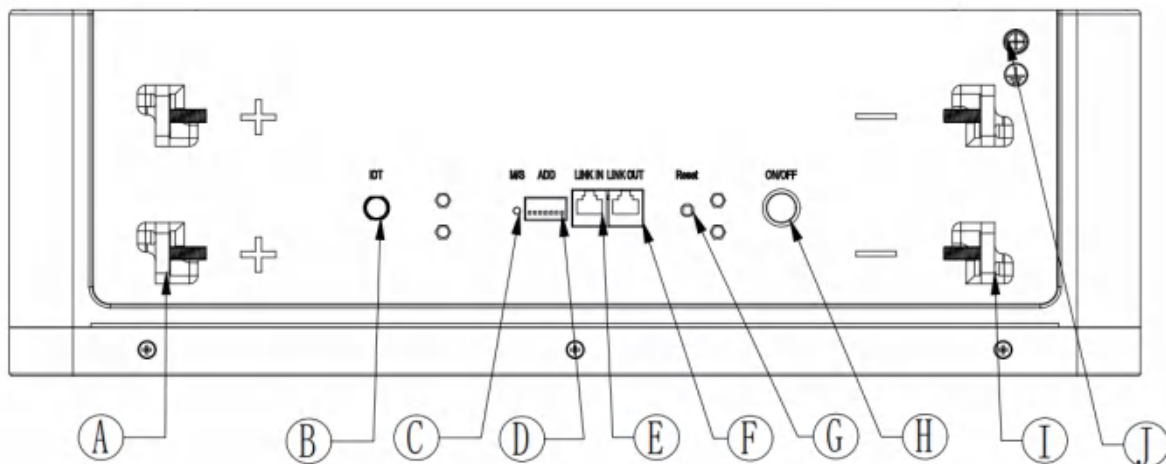

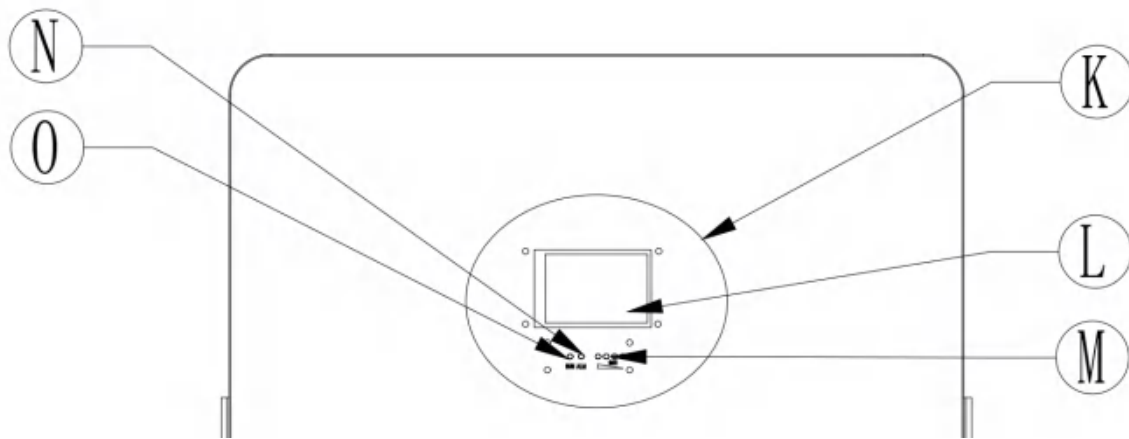

No.	Items	Usage description	Remark
A	Positive terminal	Used to connect the inverter/charger	
B	IOT	Used to connect with cloud platforms	
C	M/S	Used to indicate the module is Master or Slave battery	Single mode: OFF Parallel mode: ON- Master battery OFF- Slave battery
D	DIP	Used to set the RS485 baud rate and inverter protocol choosing	
E	Link IN	For internal and external communication	
F	Link OUT		
G	Reset	Used to sleep(3s)/awake(3s)/reset(6~10s) BMS in power on mode.	
H	Power switch	Used to Power on/off battery	
I	Negative terminal	Used to connect the inverter/charger	
J	Ground	Used to connect battery with ground	
K	PET	Decorative film	
L	LCD	Used to show battery information	
M	SOC	Used to show battery real-time SOC	Please see 3.3.3.3 for flashing specifications
N	ALM	Used to show battery Alarm/Protection status	
O	RUN	Used to show battery is in running status when lighting or flashing	

3.3.3.1 G: Link IN / Link OUT



Port	Pin No.	Definition	Remarks
Link IN	1	RS485-B1	1.Used to connect with external devices to establish communication. 2.Used to connect with upper battery pack Link OUT.
	2	RS485-A1	
	3	SGND	
	4	CAN-H	
	5	CAN-L	
	6	SGND	
	7	RS485-A1	
	8	RS485-B1	
Link OUT	1	RS485-B2	Used to connect with downward battery pack Link IN.
	2	RS485-A2	
	3	SGND	
	4	CAN-H	
	5	CAN-L	
	6	SGND	
	7	RS485-A2	
	8	RS485-B2	

3.3.3.2: DIP addressing

DIP						Remarks	
RS485 baud rate	Undefined				Protocol		
1	2	3	4	5	6	7	
ON: 115200	Reserved for multiple cluster parallel and other future function				0	0	Protocol ID0
OFF: 9600					1	0	Protocol ID1
					0	1	Protocol ID2
					1	1	reserved
Keep all batteries the same setting	Keep default setting				Master: according to inverter Brand Slave: keep default setting		

Note:







Only master battery needs to set the Protocol ID, keep all slave battery default setting, after choose the protocol ID, the battery will detect automatically the inverter information and corresponding to get into running, restart to take effect after setting new DIP sequence.

CANbus Connection		RS485 Connection		DIP setting (Master battery)
Protocol ID	INVERTER	Protocol ID	INVERTER	
CAN 1	Victron/SMA/Studer Innotec/Sofar	RS485 1	SUNGOLDPOWER SPH/Voltronic/RCT/ MPP/Alpha outback/ Phocos	 X000000
CAN 2	SUNGOLDPOWER SG/ Sol-Ark/Solis/Goodwe/Deye/ Growatt/SAJ/LUXPOWER/ Megarevo/INVT/Sermatec/ MUST/Sunsynk	RS485 2	SUNGOLDPOWER SPH	 X100010
CAN 3	Schneider	RS485 3	LUX POWER	 X010001

⚠ NOTICE

Fail to follow the DIP switch setting will cause the communication fault between battery and inverter, for more detail setting with different inverter/charger, please contact your supplier for consultation.

3.3.3.3 RUN/ALM/SOC

Mode	Status	RUN	ALM	LED indicator				Description
								
Power off	-	OFF	OFF	OFF	OFF	OFF	OFF	All OFF
Standby	Normal	FLASH1	OFF	According to battery SOC				See note
	Warning	FLASH1	FLASH3					
Charge	Normal	ON	OFF	According to battery SOC (highest SOC LED: FLASH2)				See note
	Warning	ON	FLASH3					

	COCP	FLASH1	OFF	According to battery SOC				Stop charging
Discharge	Normal	FLASH3	OFF	According to battery SOC				See note
	Warning	FLASH3	FLASH3					
	CUVP/PUVP	OFF	FLASH3	OFF	OFF	OFF	OFF	Stop discharging
	DOCP	OFF	ON	OFF	OFF	OFF	OFF	Stop discharging
Temperature	CHTP/DHTP CLTP/DLTP	OFF	ON	OFF	OFF	OFF	OFF	Stop charging/discharging
Failure	Cell/NTC failure Sensor failure MOS failure Reversed polarity /SCP	OFF	ON	OFF	OFF	OFF	OFF	Stop charging/discharging

Note: 'Warning' including items of cell imbalanced/low voltage/high current/high&low temperature.

FLASH Type	ON	OFF
FLASH1	0.25S	3.75S
FLASH2	0.5S	0.5S
FLASH3	0.5S	1.5S

3.4 Protection function

Items	Description	Remark
Charge end COVP POVP	The BMS will stop charging if any cell or PACK voltage reach the protection value and it will be auto-released only when both Pack and cell voltage back to the release voltage range or there is efficient discharge current.	
Discharge end CUVP	The BMS will stop discharging if any cell or PACK voltage is under the protection value and it will be released only when all	Can Automatic recovery. Please charge

PUVP	the cell voltage back to the release voltage range or there is efficient charge current.	timely, otherwise it may be in Low-power mode to be over-discharged and damage battery.
CHTP DHTP	The BMS will stop charging or discharging or both if any cell/environment/MOS temperature is beyond the range.	Automatic recovery when temperature falls.
CLTP DLTP	The BMS will stop charging or discharging or both if any cell/environment/MOS temperature is under the range.	Automatic recovery when temperature rise.
COCP	The BMS will stop charging when the charging current is higher than the protection value. And it will release from the protection when the system delays time is met.	Automatic recovery. If locked after three consecutive times, manual intervention is required.
DOCP	The BMS will stop discharging when the discharging current is higher than the protection value. And it will release from the protection when the system delays time is met	Automatic recovery. If locked after three consecutive times, manual intervention is required.
SCP Reversed polarity	The BMS will stop charging when detect short circuit or reversed polarity.	Charge to release. Manual press reset.
Temperature, Voltage, Current sensor failure	Enter the failure mode, manual intervention is required no charging and discharging.	Manual intervention.
Sleep mode	After reaching a certain condition, BMS will enter dormancy mode to reduce BMS consumption	Charge, press reset or restart to activate.

CAUTION

Please re-charge the battery via MPPT, grid/generator or other energy source within 24h if the battery is over discharged, otherwise, it may be damaged.

NOTICE

Manually short-circuit and reverse the battery will void the warranty.

4 Installation

4.1 Preparation

4.1.1 Safety Compliance







The system installation must be finished by qualified person(s), During the whole installation process, please strictly follow the local safety regulations and related operating procedures.

4.1.2 Environment

The operating environment shall meet the following requirements:

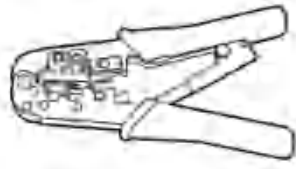
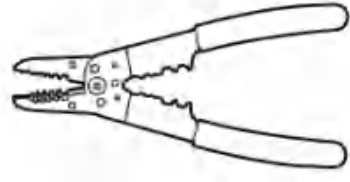
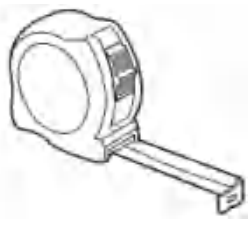
Category	Description
Working temperature	14°F (-10°C) -122°F (50°C) (maximum operating range) 59°F (15°C) -86°F (30°C) (optimal temperature)
Relative humidity	5%~90%, No condensation
Altitude	<3000m
Safety requirement	<ul style="list-style-type: none"> • Do not expose the battery to direct sunlight, rain and snow. • Do not place the battery within children/pet touchable area. • Do not place the battery near heat source and flammable material • Do not drop, deform, impact, cut or spearing with a sharp object. • Do not put heavy things on battery. • Do not disassemble the battery without Manufacturer's permission. • No conductive dust and water or other liquid to contact battery. • Follow the emergency measure if there is water invasion or electrolyte and gas leakage. • Contact your supplier within 24 hours if any product failure happens.

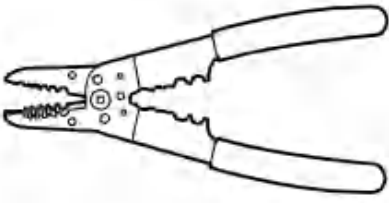
4.1.3 Tools

Tools	
<p>Torque screwdriver</p> 	<p>Multi-meter</p> 
<p>Torque wrench</p> 	<p>Cable crimper</p> 
<p>Wire stripper</p> 	<p>Tape measure</p> 
<p>Flat-head screwdriver</p> 	<p>Phillips-head screwdriver</p> 
<p>Wire stripper</p> 	<p>Drill</p> 
<p>Phillips-screwdriver bit</p> 	



4.2 Inspection









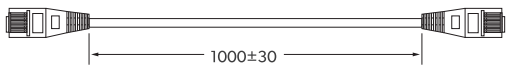

4.2.1 Unpacking

- Please load and unload it in accordance with the specified requirements to prevent sun and rain when you receive the equipment.
- Please check and confirm the goods (such as quantity, appearance, etc.) according to the "scope of delivery " before unpacking.
- Do light take and put during unpacking process to protect the surface coating of the object;
- Please record and feedback to the manufacturer if the inner packing is damaged after unpacking.

4.2.2 Scope of delivery

Check the scope of delivery for completeness and any externally visible damage. Contact your supplier for supplementary delivery if the listed material is incomplete or damaged.

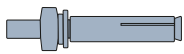
General materials <i>(Battery unit)</i>	
	
Battery Pack *1pcs	Manual *1pcs

Type	Detail	Qty.
Power cable		1PCS
		1PCS
Grounding cable		1PCS
Battery to battery communication cable		1PCS
Floor to wall fixed bracket		2PCS
Expansion screw	 M6*50	2PCS
Wall mounted installation (optional)		
Wall mounted bracket		1PCS
Battery Wall mounted bracket		2PCS
Wall mounted limit bracket		2PCS
Expansion screw	 M10*80	4PCS
Screw	 M6*16	12PCS

For inverter communication PIN definition detail, please check **Appendix I**

 **NOTICE**

Keep the unused cable pins NULL to avoid affecting the closed loop communication.

 **NOTICE**

A ground connection of communication cable may be required from some inverters, please follow the rules from inverter manufacture.

4.3 Start Installation

 **Qualified person**

4.3.1 Remainder

Please check again the following conditions or equipment whether meet the requirements before installation:

- Check if there's enough space for installation, and if the load-bearing capacity of the bracket or cabinet meets the weight requirements.
- Check whether the power cable pair(s) used meets the maximum current requirement for operation.
- Check whether the overall layout of power supply equipment and batteries at the construction site is reasonable.
- Check whether the installer is wearing anti-static wristband.
- Check whether there're two people on the construction site for installation work.
- Check if there's potential risks at location of installation site, e.g flooding, sun exposure, corrosion, and salt spray.

4.3.2 Procedures



⚠ CAUTION

Injuries may result if the product is lifted incorrectly or dropped while being transported or mounted.
Wear suitable personal protective equipment for all work on the product.

⚠ CAUTION

Ensure that no lines are laid in the wall which could be damaged when drilling holes.

4.3.2.1 Floor mounted installation

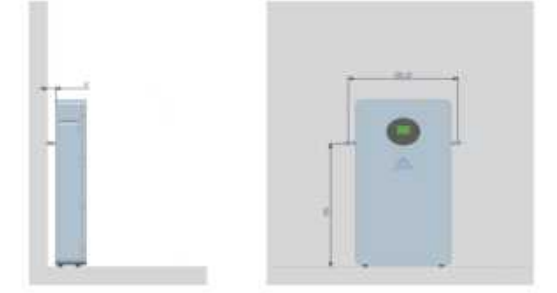
<p>i. Take the battery pack out from package.</p>	
<p>ii. Fasten the two wall mount brackets together</p>	
<p>iii. Fix the assembled bracket in the corresponding position of the battery as shown in the figure</p>	
<p>iv. Attach the battery with the assembled stand to the wall</p>	

<p>v. The installation is completed and the final minor changes are shown on the right</p>	
<p>vi. Finish the cable connection</p>	

⚠ CAUTION

Please fix the parallel cable between batteries with the wall or other part to avoid enduring the gravity of conductor for long time, resulting in an increase in the internal resistance of the connection.

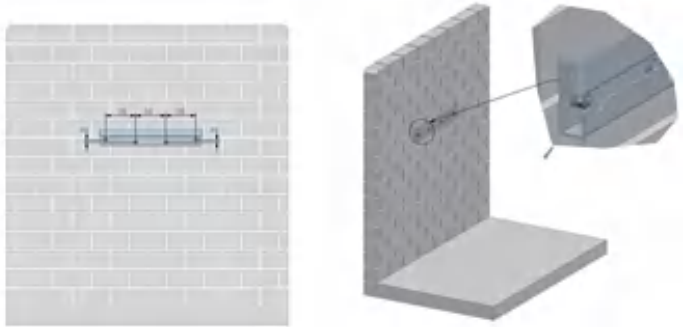

4.3.2.2 Wall mounted installation(optional)

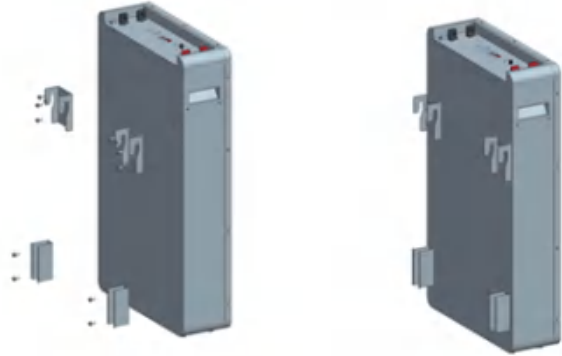
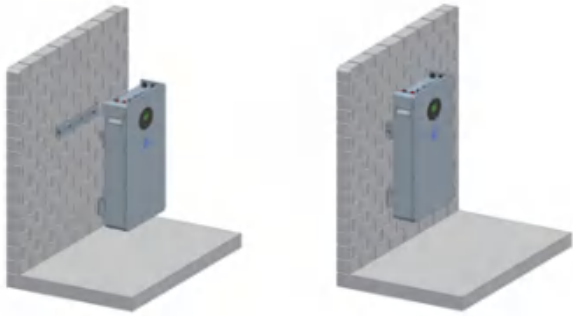
<p>i. Take the battery pack out from carton.</p>	
<p>ii. Take out the wall mounting bracket, place it onto the wall horizontally and mark the hole position on the panel.</p>	
<p>iii. Drill holes in the wall for the M10 expansion bolt. The drilling depth should be at least 60 mm, insert the bolt.</p>	

<p>iv. Fix the breaket with the nut</p> <p>v. Use combination screws to secure wall mount components to the battery</p>	
<p>vi. Hang the battery on the wall bracket</p>	
<p>vii. Finish the cable connection</p>	

4.3.3 Tips

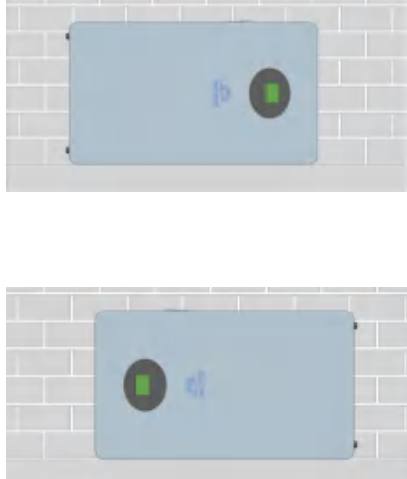
4.3.3.1 Installation not allowed

Direct upside down	Left/Right side flip	Floor side flip
 <p style="text-align: center; color: red; font-weight: bold;">X</p>	 <p style="text-align: center; color: red; font-weight: bold;">X</p>	 <p style="text-align: center; color: red; font-weight: bold;">X</p>
<p>Direct upside down</p>	<p>side flip</p>	<p>Front side down</p>

5. Cable connection and commissioning

5.1 Get battery ready

5.1.1 Ensure all the battery is in OFF mode, check and confirm the installation is tighten and stable.

5.1.2 Check the number and specification of cable kit accessories are correct according to the Scope of delivery item, if you are making cable yourself, please follow manufacturer's requirements.

5.1.3 Switch on all battery individually before wiring, check whether there is any alarm/protection information, if yes, turns to troubleshooting. Then switch off all batteries.

5.2 Grounding cable connection

5.2.1 Take out the grounding screw on the battery panel, and get the cable conductor through it.

5.2.2 Fix them together, with a cylinder screwdriver and tighten it.

5.2.3 Connect the grounding cable with next battery module.

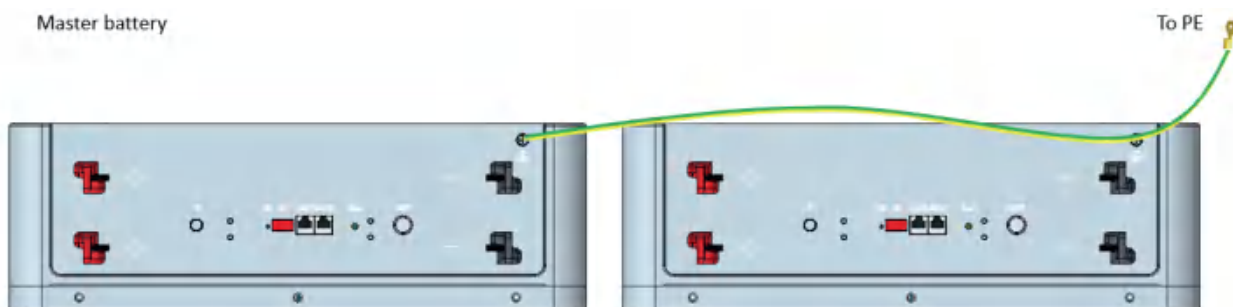

5.3 Communication cable connection

5.3.1 Take out battery to battery communication cable.

5.3.2 Confirm the location of Master battery, insert the RJ45 plug into the Link Out port and connect the other side to next battery Link IN port, daisy chained all batteries.

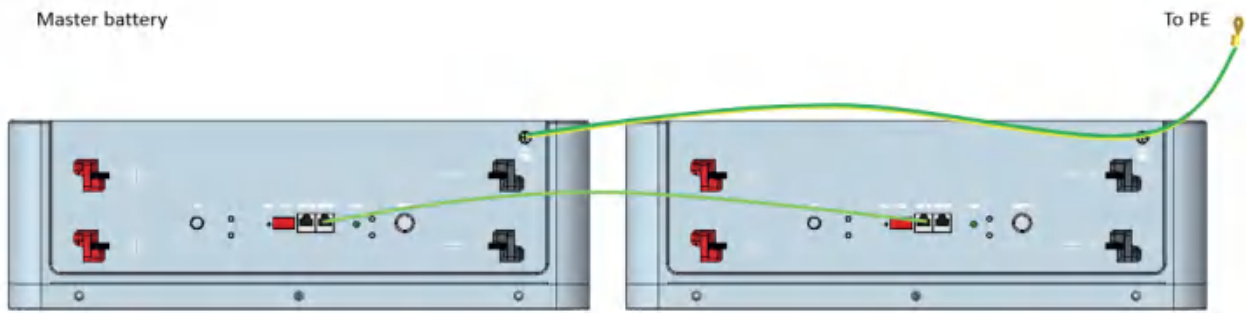

Note: the module with empty Link IN port is Master battery

⚠ NOTICE

The BMS inside the battery pack will automatically terminate BOTH end of CANBUS pins, DO NOT need to plug the 120 Ω terminator again.

5.4 DC power cable connection

5.4.1 Take out battery to battery power parallel cable.

5.4.2 Lock the terminals on the battery terminals and secure tightly with nuts.

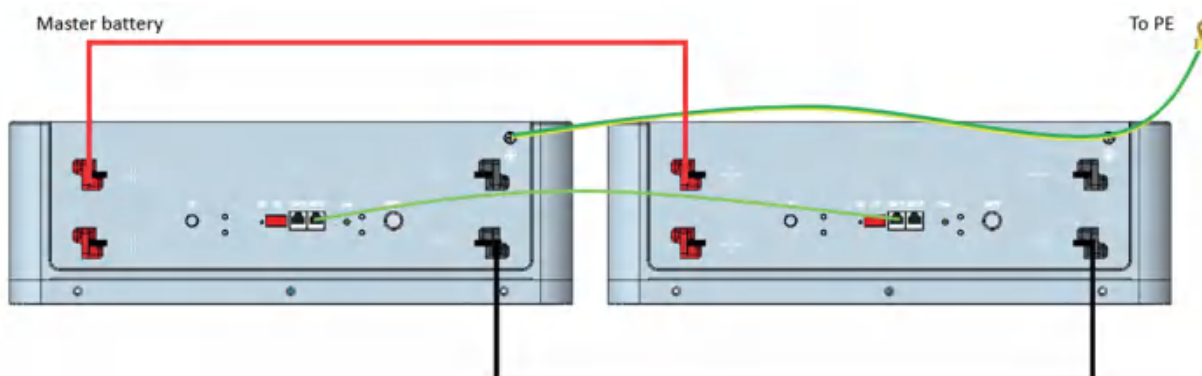

5.5 Connecting with inverter

⚠ CAUTION

Confirm inverter AC input and PV input is disconnected before wiring connection, and the DC/ signal switch of inverter/charger is in off status.

5.5.1 Connecting Master battery Link IN port with inverter CAN or RS485 communication port via inverter communication cable (*Version I/II/III or customized*).

5.5.2 Connecting battery OUTPUT (+) with inverter battery INPUT (+), battery OUTPUT (-) with inverter battery INPUT (-), an external disconnection breaker between battery system and inverter is recommended, choose the corresponding power cable pair and wiring them correctly.

Note:

! NOTICE

Choose the suitable disconnection breaker considering the inverter power/current, rated voltage, tripping characteristic etc.

Wiring diagram allowed:

i. Single pair cable wiring----200A, 10KW rating

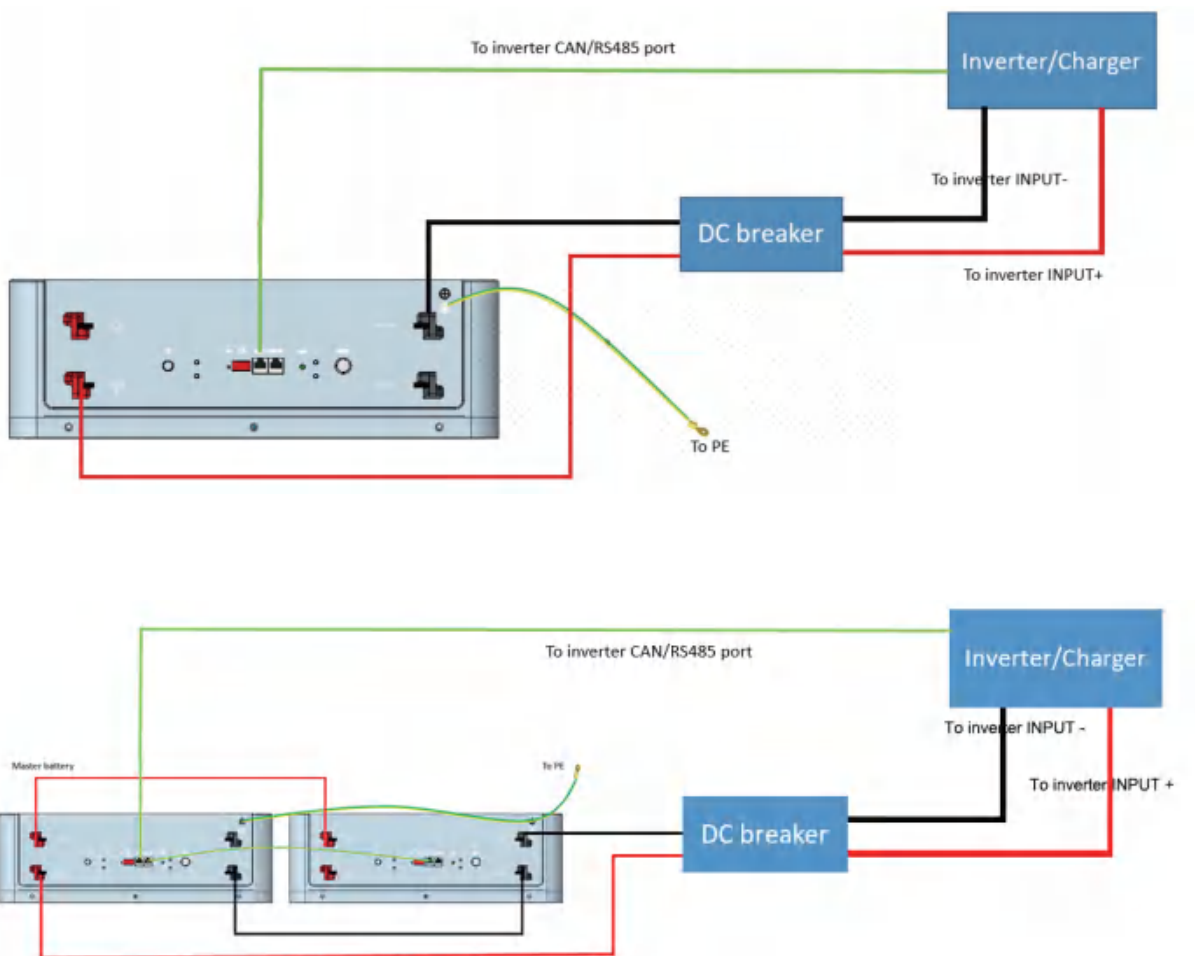

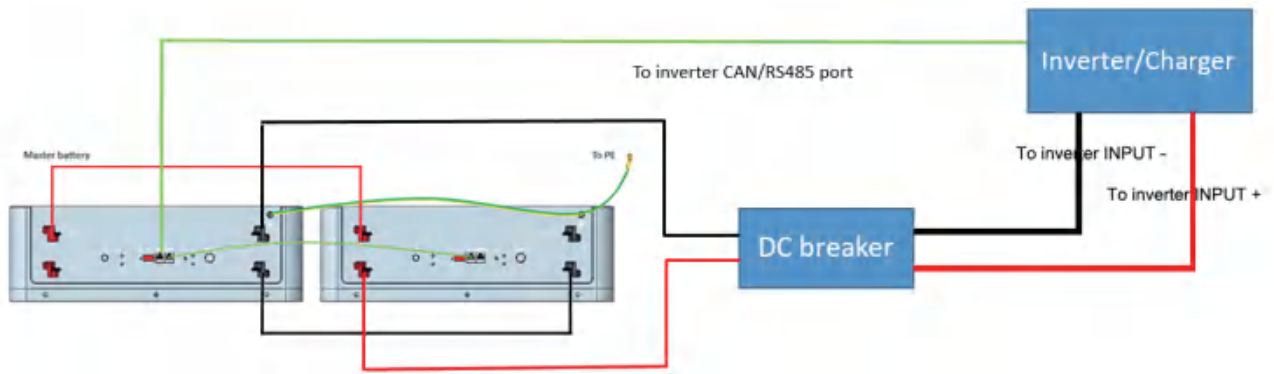

ii. Double pairs cable wiring----300A, above 10KW

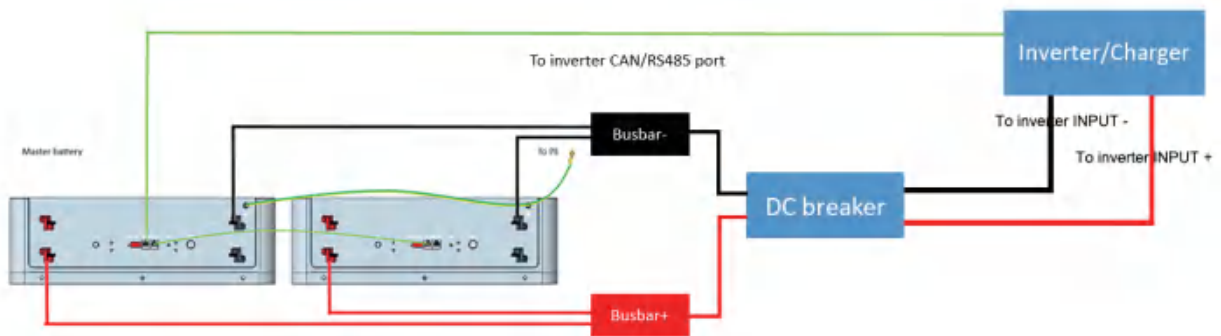

iii. Multiple towers and inverters cable wiring

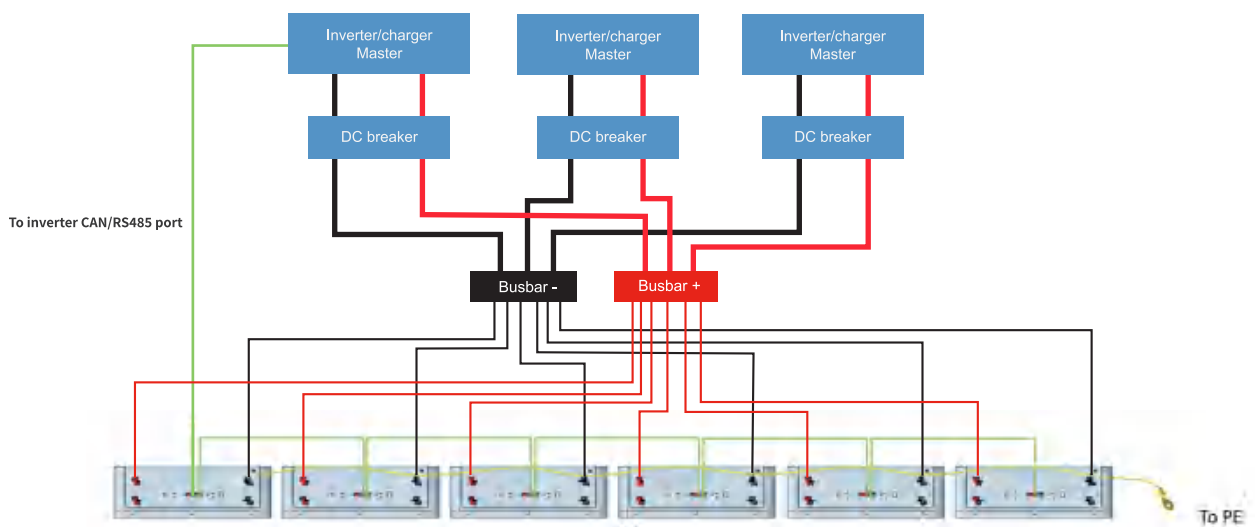

Considering system stability, when you install multiple batteries, please always keep a certain capacity

margin of 30~50%. it is recommended to configure the inverter capacity with battery energy in 1: 2 proportion, for instance, if you have a 10KW rated inverter, connect 2 pieces(20KWh) or more batteries.

Wiring diagram not allowed:

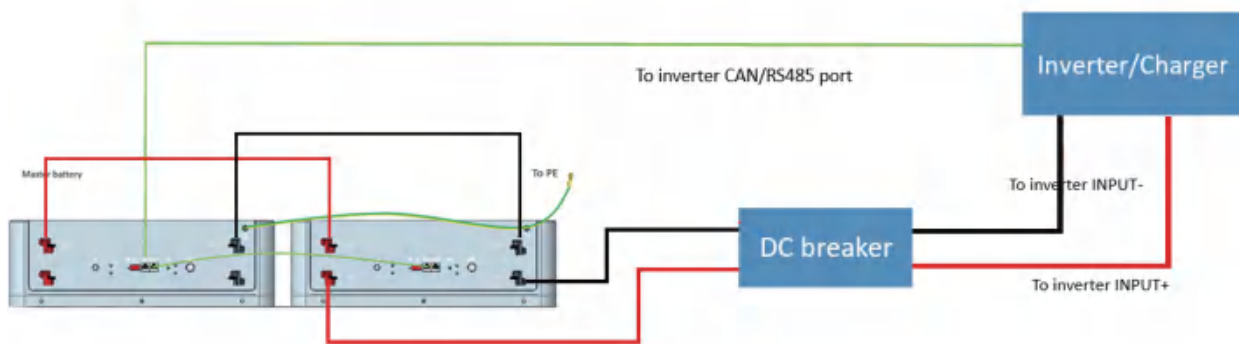

⚠ NOTICE

The maximum communication cable length is required to be less than 15m between inverter/charge and battery.

The maximum power cable length is suggested to be less than 10m between inverter/charge and battery.

⚠ CAUTION

The maximum allowable current per power cord is 200A, with 150A recommended for continuous use, and the maximum allowable current for the battery terminals is 200A, with 150A recommended for continuous use. Please use the appropriate number of power cord pairs according to the site configuration and local connection requirements, standards and directives.

5.6 Commissioning

5.6.1 Set the DIP address of the Master battery (and the Slave battery if there is any RS485 baud rate changed).

5.6.2 Switch on all battery modules, wait for 10s, make sure that only M/S led is on Master battery.

5.6.3 Turn on the breaker between the inverter and battery if there is any, then turn on the inverter/charger isolator.

5.6.4 Finish the setting on inverter/charger or any other control devices, if everything is correct, you are ready to use the system.

No.	Inverter setting parameters	Detail
1	Absorption voltage	56.0V
2	Float voltage	54.6V
3	Re-charge/Generator start voltage	$\geq 50V$
4	Re-start voltage	52V
5	Low SOC limit (Grid-tied)	10/20% (differ from inverter brand)
6	Low SOC cut-off (Off-grid)	4%
7	Low Voltage cut-off	48.0V
8	Rated charging current limited value	100A*N (N is the Quantity of the battery pack)
9	Rated discharging current limited value	100A*N (N is the Quantity of the battery pack)
10	Max. charging current limited value	200A*N (N is the Quantity of the battery pack)
11	Max. discharging current limited value	200A*N (N is the Quantity of the battery pack)
12	Force charge/ Activate	Enable

For more information to connect with different inverter/charger, please contact your supplier for technical support.

CAUTION

If your system is a back-up or off-grid system, make sure your configuration can cover the worst situation to avoid battery to be over-discharged.

5.7 Switch off battery

5.7.1 Turn off the inverter.

5.7.2 Turn off the disconnection breaker if there is any.

5.7.3 Turn off all batteries signal switch.

6 Troubleshooting and FAQ

Items	Solution	Measure
Unable to start	<ol style="list-style-type: none"> 1. Power on battery and press RESET 6s to observe whether the battery can be started. 2. Charge the battery use a charger or inverter to provide 54~57.6V voltage and observe it can be started. 	<p>If the abnormal status still alive after above steps, please contact your supplier.</p> <p>If there is any other situation(s) excluding in this table, turn off the fault battery, contact your supplier.</p>
Unable to charge	<ol style="list-style-type: none"> 1. Check whether the cable connection between the battery and the inverter/charger is correct. 2. Check whether the inverter/charger setting is correct. 3. Check whether the battery is in charge protection mode, if yes, try to discharge the battery. 	
Unable to discharge	<ol style="list-style-type: none"> 1. Check whether the cable connection between the battery and the inverter/charger is correct 2. Check whether the battery occurs short circuit, reverse connection, pre-charge failure during connection inverter etc. 3. Check whether the battery is in discharge protection mode, if yes, try to charge the battery. 	
High/Low temperature	<ol style="list-style-type: none"> 1. Stop the battery system for a while, check whether the installation location temperature meet the requirement. 2. Avoid continuous full charging and discharging. 	
High current	Check the configuration and parameters setting on the inverter/charger is correct.	
ALM always on	<ol style="list-style-type: none"> 1. Check the fault information on the inverter APP or display if possible. 2. Ask your supplier to offer BMS monitoring software to locate the reason and back to them for solution. 	
Communication fail	<ol style="list-style-type: none"> 1. Check the communication cable type is correct and is contacted well. 2. Check the DIP switch setting is correct. 3. Check the inverter protocol related setting is correct. 4. Check both battery and inverter are working properly. 	
LCD Display		
●HV	<ol style="list-style-type: none"> 1. Stop charging the battery. 2. Try to discharge the battery. 	
●LV	<ol style="list-style-type: none"> 1. Stop discharging the battery. 2. Try to charge the battery. 	
●COC	<ol style="list-style-type: none"> 1. Lower the charge current 	
●DOC	<ol style="list-style-type: none"> 1. Lower the discharge current 	
●CHT& ●DHT	<ol style="list-style-type: none"> 1. Stop the battery system for a while, check whether the installation location temperature meet the requirement. 2. Avoid continuous full charging and discharging. 	

●SL	1. Stop discharging the battery. 2. Try to charge the battery.	
●AFE	1. please contact your supplier to replace the BMS.	

Q1: Battery maximum SOC is 98~99% and never goes to 100%SOC during daily cycle use, why?

This is normal and have no influence on capacity, usually BMS will calibrate the SOC to 100% when reached cut-off current or trigger HVP, however, to avoid battery from being overcharged and to extend the cycle life as longer as possible, we left a room and set a charging profile to let battery charge slowly near full, please float the battery about 0.5~1 hour to calibrate the SOC.

Q2: 'High voltage' and 'cell unbalance' warning and alarm in rare cases, does it mean battery is damaged?

No. This is not unusual and happened on new batteries that are not balanced yet, please lower the maximum charge voltage (54.6V) and float the battery via grid or generator. If not solved, please contact your supplier.

Q3: When having multiple batteries in parallel connection, the battery on the end can't be fully charged.

Pay attention to your wiring diagram, please always follow the manual wiring advises and choose proper cable size and pair.

Q4: The current is 0A when connecting with a very small load at the situation that having multiple batteries in parallel connection, how to solve it?

Each BMS has a threshold current of 0.5A (~25W) before it begins to report, this leads the inaccurate display of the current.

Q5: SOC is not accurate or suddenly jumps to 100% during charging.

This mostly happen in off-grid applications on batteries that have not been calibrated SOC for a long time or situations that are similar to Q4 that with inverter in Idle mode or a small DC load or store the battery for a long time, we suggest fully charging at once the batteries per month refer to Q1.

Q6: The system is still running when the inverter log shows 'internal failure' Warning.

This is our logic and this warning flag indicates there is 1 or more module(s) is in communication offline from the system, the system will derating and until communication is recovered.

Q7: Inverter pulling power from Grid to charge batteries in self-consumption mode.

When reached certain conditions such as low state of charge etc., battery will send charge request to ask inverter to charge the batteries, to avoid this, please discharge DOD as manual suggested.

7. Transport, Storage

- Do not violently shake, impact or squeeze, and prevent sun and rain during the transportation.
- Do light take and put and strictly prevent falling, rolling, and heavy pressure during loading and unloading.
- The battery should be placed in a dry, clean, dark, and well-ventilated indoor environment for long-term storage, and the recommended storage temperature range is 15~30°C.
- No harmful gases, flammable and explosive products and corrosive chemical substances in the storage location.
- The batteries should be stored and transported in close to 50% SOC, do not store over 80%SOC for long time.
- If do not use for a long time, the battery needs to be charged every 6 months.
- No fall down, no pile up over 6 layers, and keep face up.

8. Disposal of battery

Disposal of battery must comply with the local applicable disposal regulations for electronic waste and used batteries, please review your local Battery recycling or management regulations or contact your supplier for more information.

Appendix I

Connect with SUNGOLDPOWER SPH/SG inverter/charger

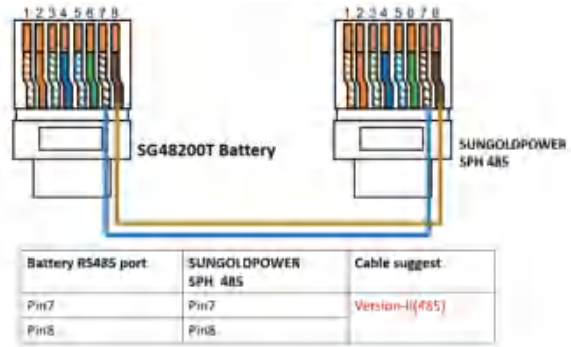
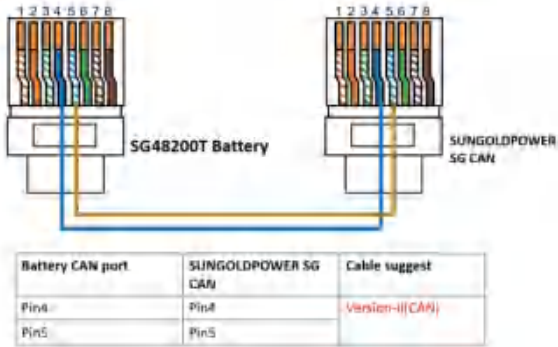

Connect with Victron GX & inverter/charger

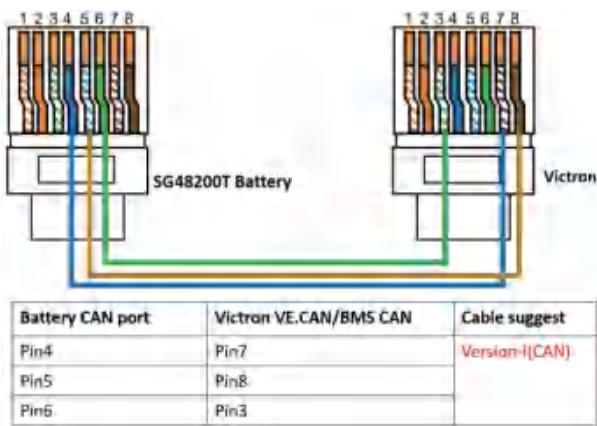

Connect with SMA inverter/charger

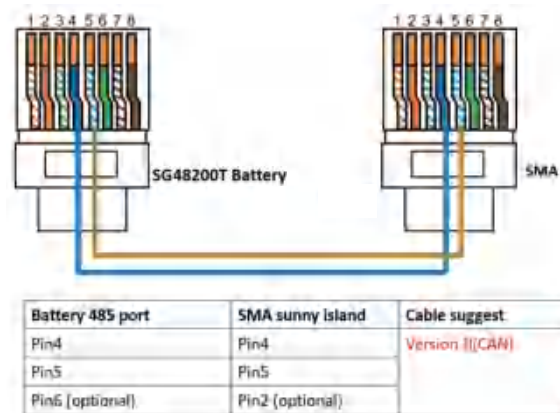

Connect with Schneider inverter/charger

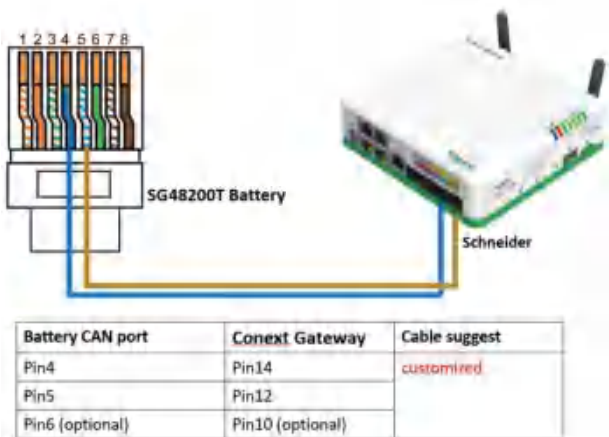

Connect with Studer inverter/charger

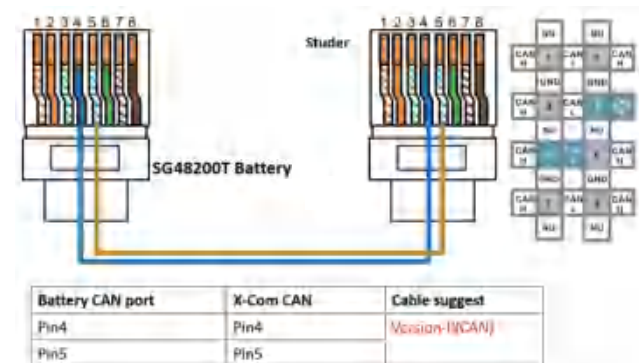

Connect with GOODWE hybrid inverter

Connect with Sol-Ark hybrid inverter

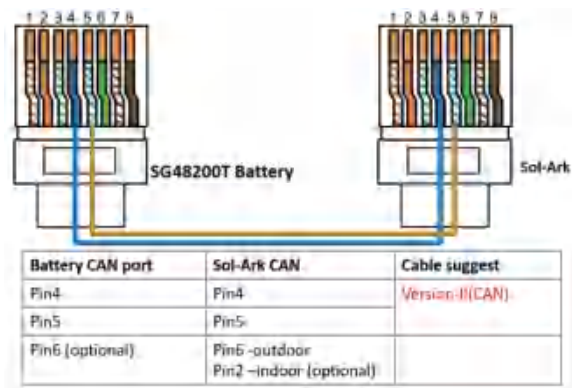
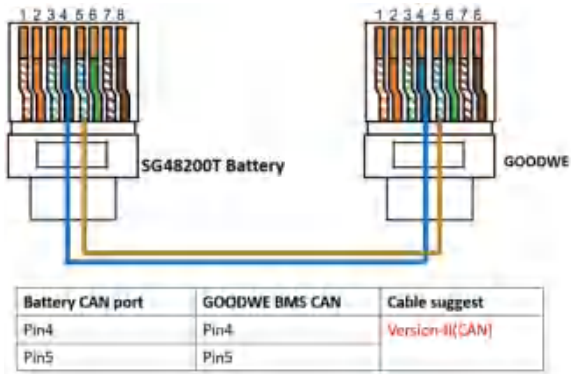

Connect with Growatt inverter

Connect with Solis inverter

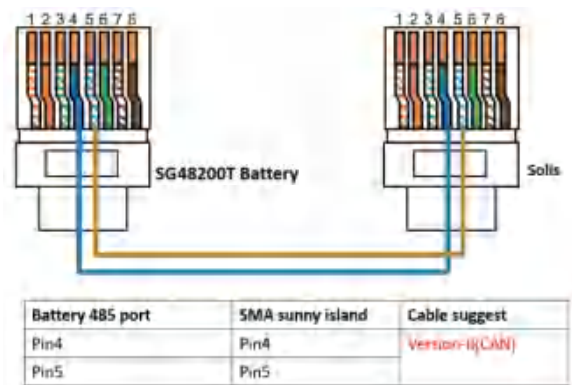
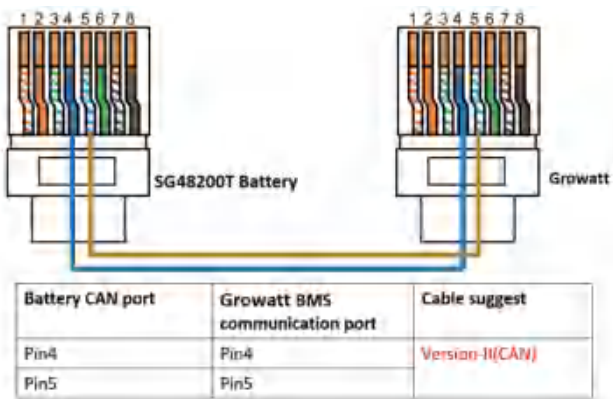

Connect with Solark hybrid inverter

Connect with SUNSYNK hybrid inverter

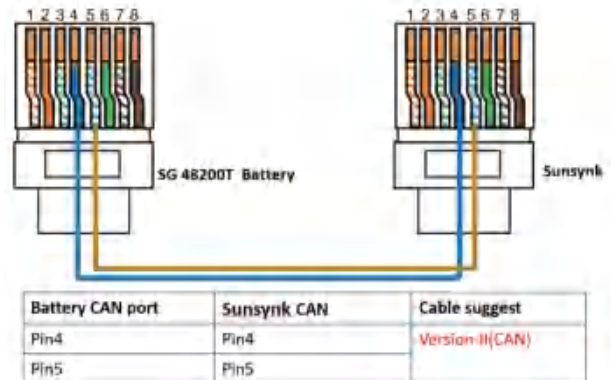
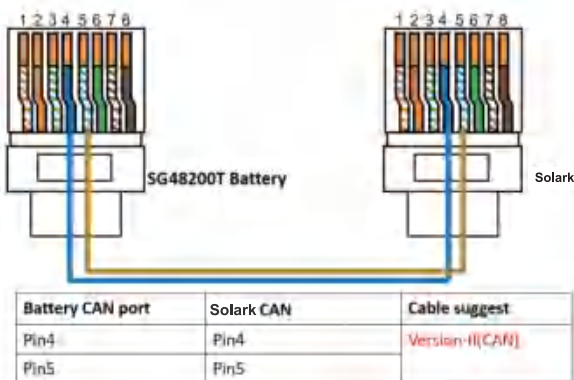

Connect with SAJ hybrid inverter

Connect with LUXPOWER inverter

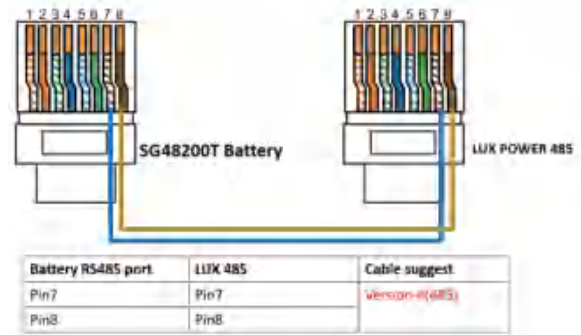
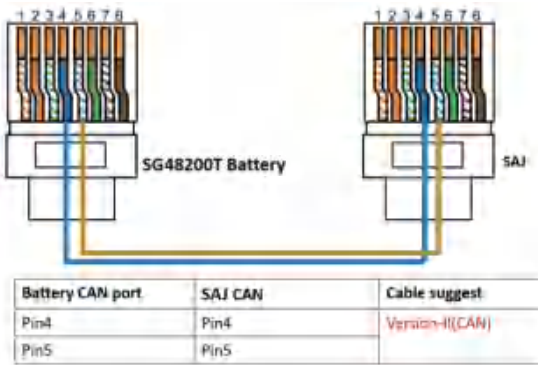

Connect with Megarevo/INVT inverter

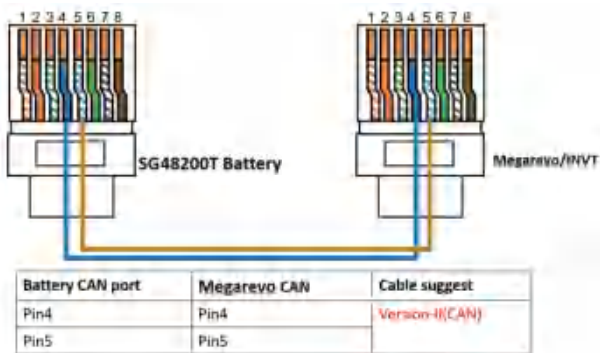

Connect with MUST inverter

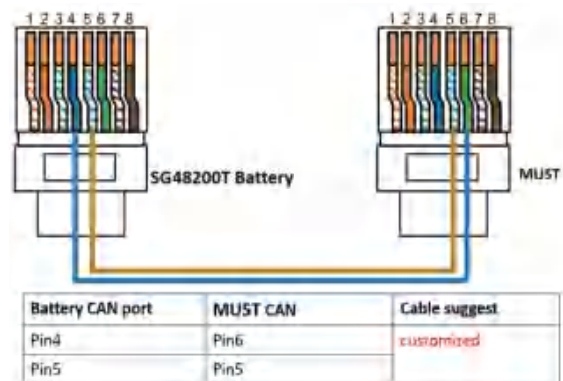

Connect with Alpha & Outback energy inverter

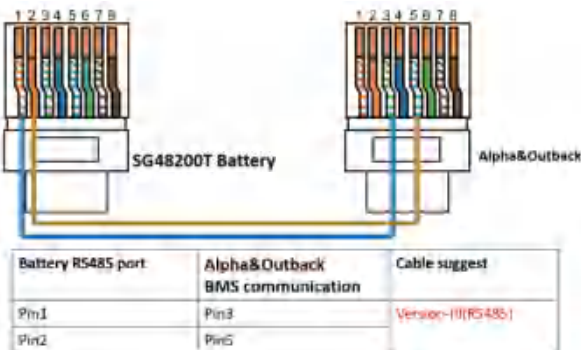

Connect with Voltronic inverter

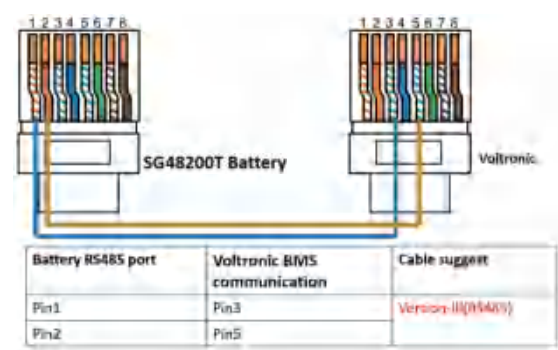

Connect with Phocos inverter

Connect with Mpp solar inverter

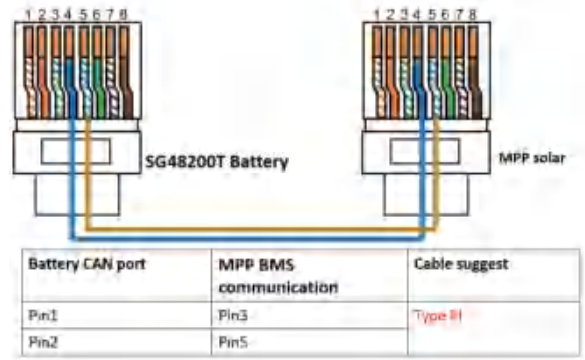
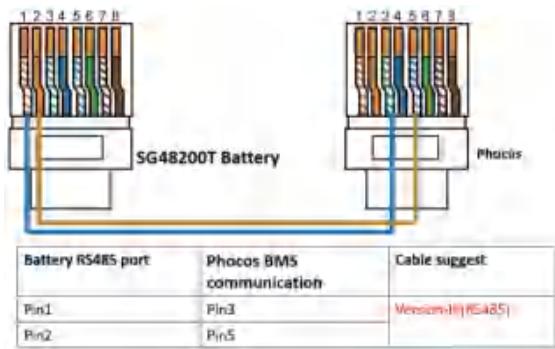

USER MANUAL



All-in-one solar charge inverter

SPH8K48SP

SPH10K48SP

Table of Contents

1. Safety	4
1.1、 How to use this manual.....	4
1.2、 Symbols in this manual.....	4
1.3、 Safety instructions.....	4
2. Production Instructions	5
2.1、 Instructions	5
2.2、 Features.....	5
2.3、 System connection diagram	6
2.4、 Production Overview	7
3. Installation	8
3.1、 Select the mount location	8
3.2、 Mount the inverter	9
3.3、 Remove the terminal protection cover and insect screen	9
4. Connection	10
4.1、 Connection Overview	10
4.2、 Cable & circuit breaker requirement.....	14
4.3、 AC input & output connection	16
4.4、 Battery Connection	16
4.5、 PV connection.....	17
4.6、 Dry contact connection	17
4.7、 Grounding connection.....	18
4.8、 Final assembly.....	18
4.9、 Start up the inverter.....	18
5. Operation	19
5.1、 Operation and display panel	19
5.2、 Setting.....	23
5.3、 AC output mode	29
5.4、 Battery charging mode.....	30
5.5、 Time-slot charging/discharging function	31
5.6、 Battery parameter.....	32
6. Communication	34
6.1、 Overview	34
6.2、 USB-B port.....	34
6.3、 WIFI port.....	35





6.4、 CAN/RS485 port.....	35
6.5、 Dry contact.....	36
7. FaultandRemedy	37
7.1、 Fault code.....	37
7.2、 Troubleshooting.....	38
8. ProtectionandMaintenance.....	40
8.1、 Protection features.....	40
8.2、 Maintenance.....	41
9. Datasheet	42

1. Safety

1.1、 How to use this manual

- This manual contains important information、 guidelines、 operation and maintenance for the following products: SPH series **8K48SP**, **10K48SP**
- The manual must be followed during installation and maintenance.

1.2、 Symbols in this manual

Symbol	Description
	DANGER indicates a hazardous situations which if not avoided will result in death or serious injury.
	WARNING indicates a hazardous situations which if not avoided could result in death or serious injury.
	CAUTION indicates a hazardous situations which if not avoided could result in minor or moderate injury.
	NOTICE provide some tips on operation of products.

1.3、 Safety instructions

DANGER

- This chapter contains important safety instructions. Read and keep this manual for future reference.
- Be sure to comply the local requirements and regulation to install this inverter.
- Beware of high voltage. Please turn off the switch of each power sources before and during the installation to avoid electric shock.
- For optimum operation of this inverter, please follow required specification to select appropriate cable size and necessary protective device.
- Do not connect or disconnect any connections when the inverter is working.
- Do not open the terminal cover when the inverter working.
- Make sure the inverter is well grounding.
- Never cause AC output and DC input short circuited.
- Do not disassembly this unit, for all repair and maintenance, please take it to the professional service center.
- Never charge a frozen battery.
- Please keep children away from touching or mishandling the inverter.
- Please make sure that this inverter is the only input power source for the load, do not use it in parallel with other input AC power sources to avoid damage.

2. Production Instructions

2.1、 Instructions

SPH series is a new type of solar energy storage inverter control inverter integrating solar energy storage & utility charging and energy storage, AC sine wave output. It adopts DSP control and features high response speed, reliability, and industrial standard through an advanced control algorithm.

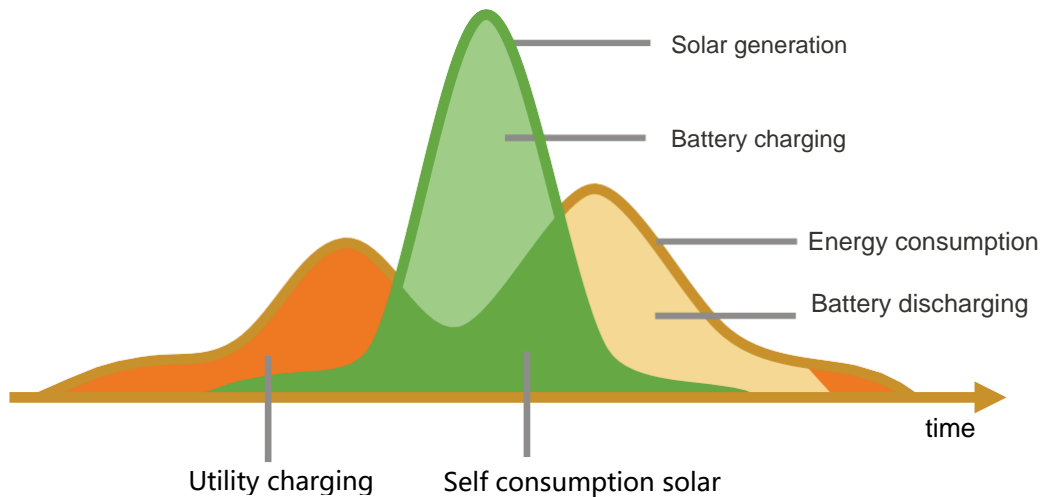

2.2、 Features

- Supports lead acid battery and li-ion battery connections.
- With a dual activation function when the li-ion battery is dormant; either mains/photovoltaic power supply access can trigger the activation of the li-ion battery.
- Support split-phase and single-phase pure sine wave output.
- Supports four different voltage levels of 100Vac, 105Vac, 110Vac, and 120Vac per phase.
- Supports two solar inputs and simultaneous tracking of two solar maximum power charging/carrying capacity functions.
- Dual MPPT with 99.9% efficiency and maximum 22A current in a single circuit, perfectly adapted to high power modules.
- 4 charging modes are available: solar only, mains priority, solar priority, and mixed mains/PV charging.
- With the time-slot charging and discharging setting function, you can set the time period for cutting in/out of mains charging and switch the time period between battery discharging and mains bypass power supply mode.
- Energy saving mode function to reduce no-load energy losses.
- With two output modes of utility bypass and inverter output, with uninterrupted power supply function.
- LCD large screen dynamic flow diagram design, easy to understand the system data and operation status.
- 360° protection with complete short circuit protection, over current protection, over under voltage protection, overload protection, backfill protection, etc.
- Support CAN, USB, and RS485 communication.

2.3、 System connection diagram

The diagram below shows the system application scenario of this product. A complete system consists of the following components:

- **PV modules:** converts light energy into DC energy, which can be used to charge the battery via an inverter or directly inverted into AC power to supply the load.
- **Utility grid or generator:** connected to the AC input, it can supply the load and charge the battery at the same time. The system can also operate generally without the mains or generator when the battery and the PV module power the load.
- **Battery:** The role of the battery is to ensure the regular power supply of the system load when the solar energy is insufficient and there is no mains power.
- **Home load:** Various household and office loads can be connected, including refrigerators, lamps, televisions, fans, air conditioners, and other AC loads.
- **Inverter:** The energy conversion device of the whole system.

The actual application scenario determines the specific system wiring method.

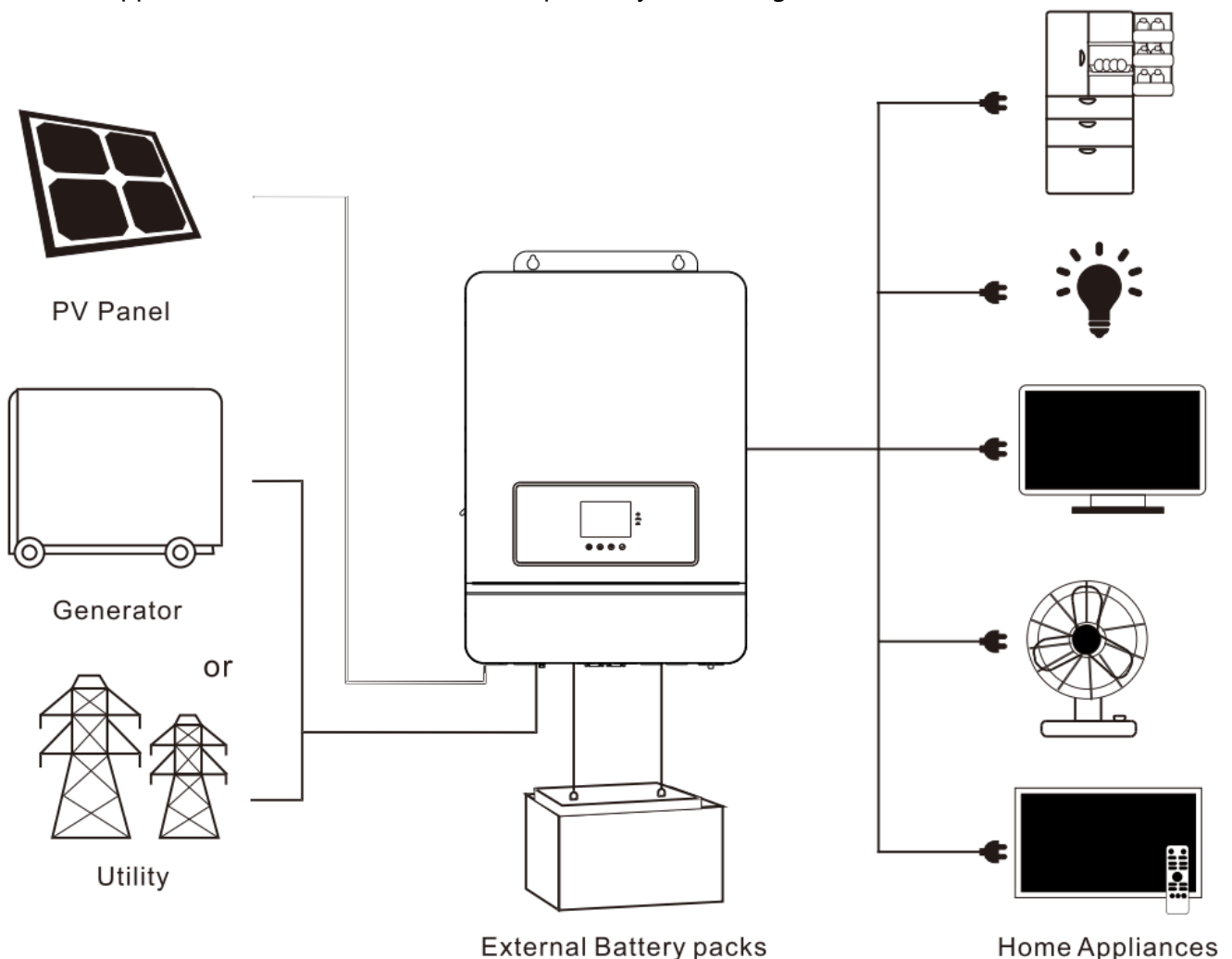

2.4、 Production Overview

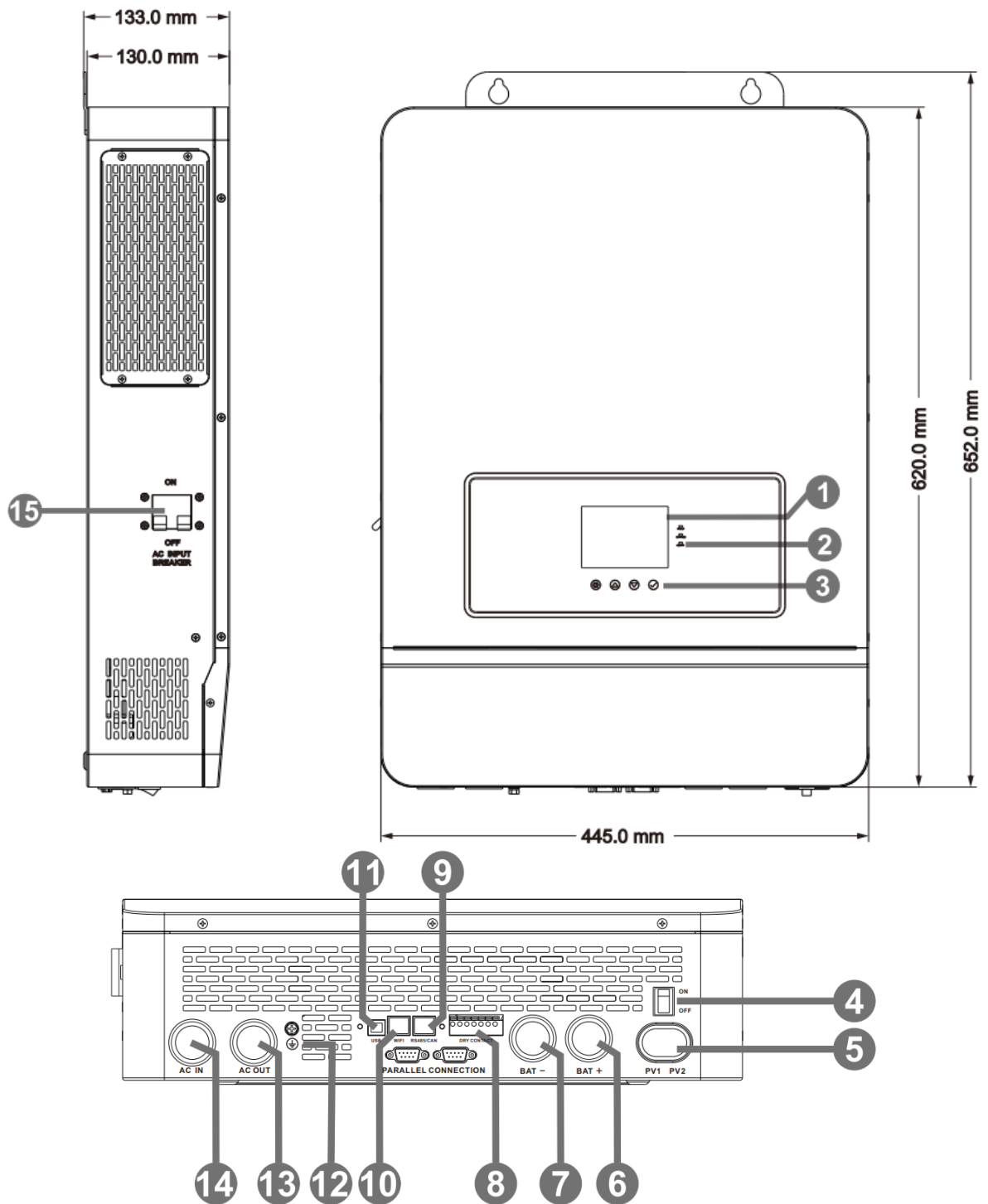

1	LCD screen	2	LED Indicators	3	Touchable key
4	ON/OFF Rocker Switch	5	PV INPUT (1/1)	6	BAT INPUT (+)
7	BAT INPUT (-)	8	Dry contact	9	RS485/CAN port
10	WIFI port	11	USB-B port	12	Grounding Screw
13	AC OUT (L+L+N)	14	AC IN (L+L+N)	15	AC INPUT breaker

3. Installation

3.1、 Select the mount location

SPH series are designed for **INDOOR USE ONLY** (IP20) . Please consider the followings before selecting the location:

- Choose the solid wall to install the inverter.
- Mount the inverter at eye level.
- Adequate heat dissipation space must be provided for the inverter.
- The ambient temperature should be between $-10\sim 55^{\circ}\text{C}$ ($14\sim 131^{\circ}\text{F}$) to ensure optimal operation.

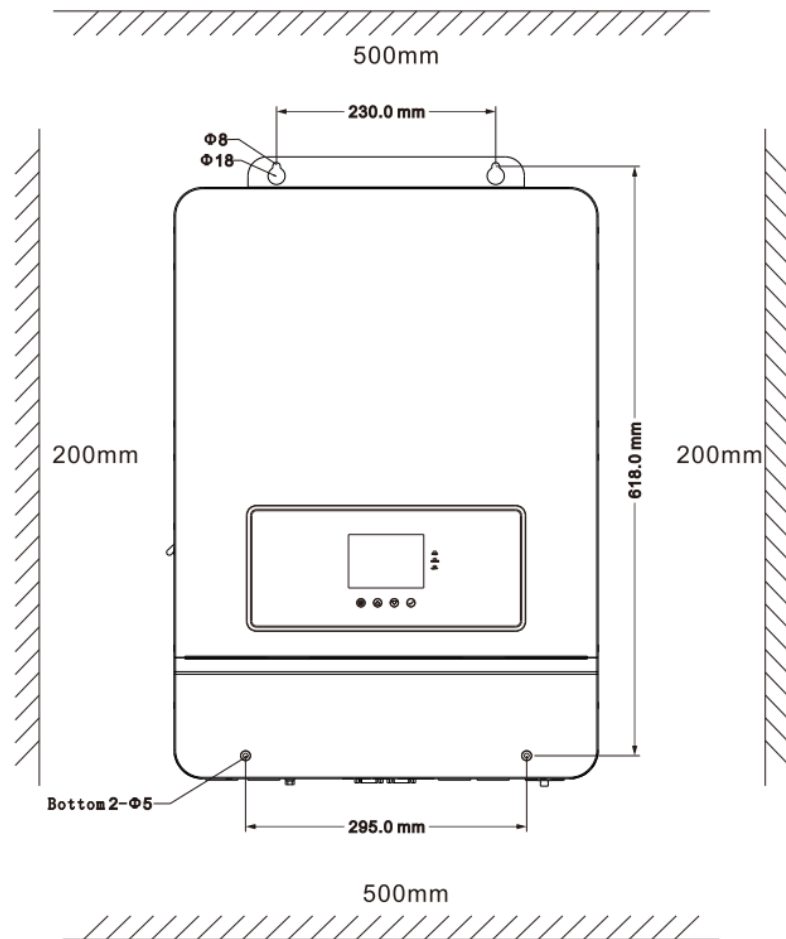

⚠ DANGER

- Do not install the inverter where highly flammable materials are near by.
- Do not install the inverter in potential explosive areas.
- Do not install the inverter with lead-acid batteries in a confined space.

⚠ CAUTION

- Do not install the inverter in direct sunlight.
- Do not install or use the inverter in a humid environment.

3.2、 Mount the inverter

Make 4 mounting holes in the wall with an electric drill according to the specified dimensions, insert 2 expansion screws above and fix the inverter with 2 M5 screws below.

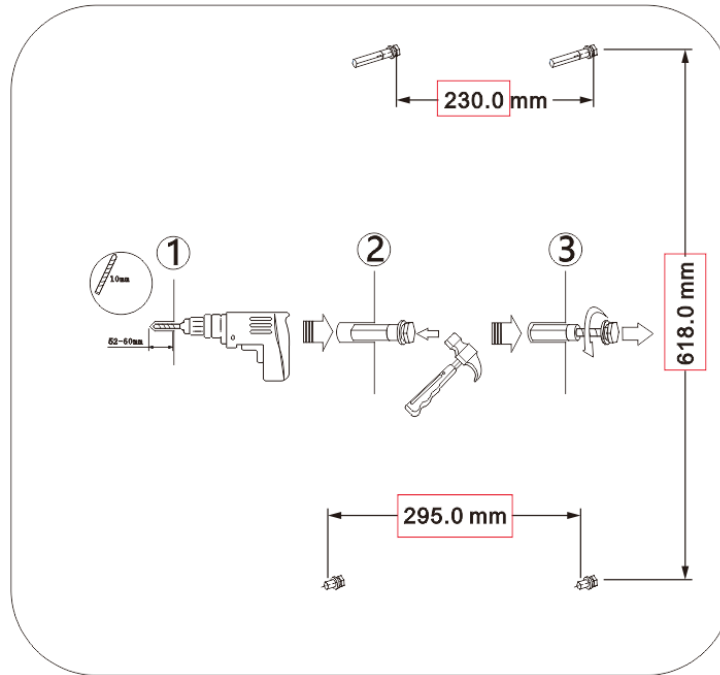

3.3、 Remove the terminal cover & anti insect net

Using a screwdriver, remove the terminal protection cover and anti insect net.

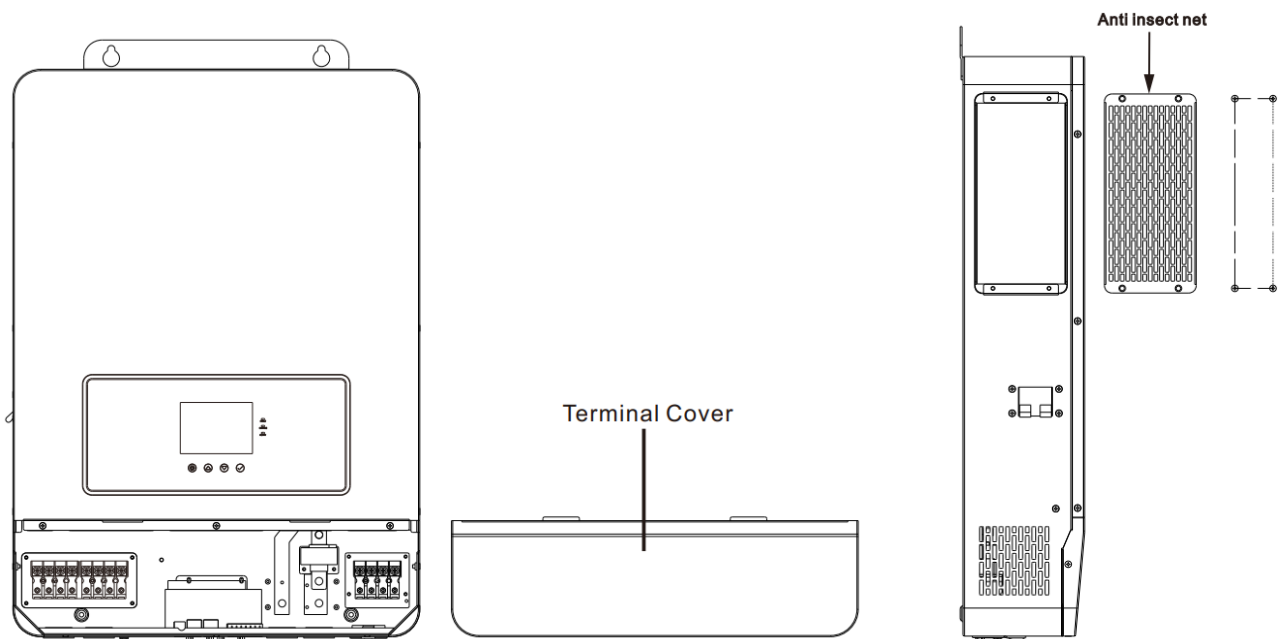

NOTICE

- When using the device in areas with poor air quality, the dust screen is easily blocked by airborne particles. Please dismantle and clean the dust screen regularly to avoid affecting the internal air flow rate of the inverter, which may trigger an over-temperature protection fault (19/20 fault) affecting the use of the power supply and the service life of the inverter.

4. Connection

4.1、 Connection Overview

- Split-phase mode (default)

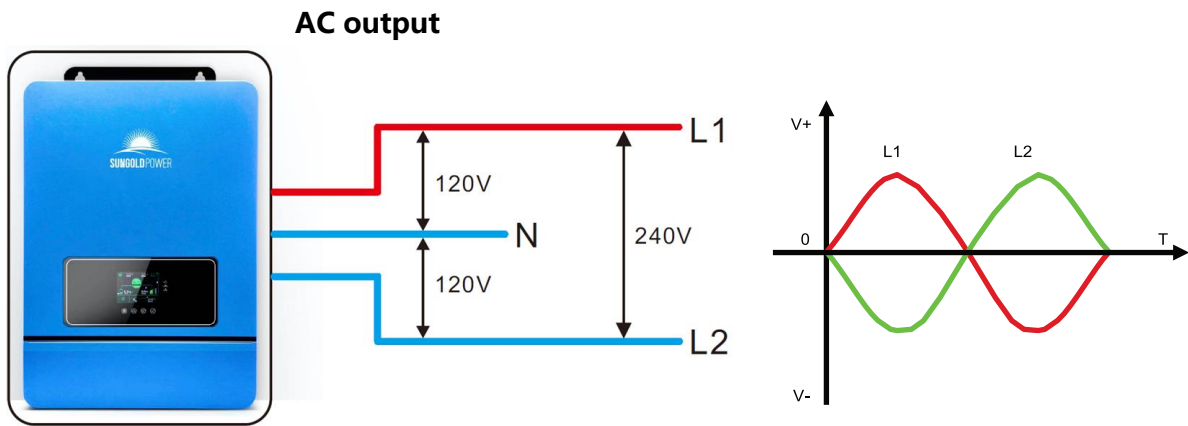

Items	Description
Applicable Model	SPH series
Output Voltage Range (L-N)	100 ~ 120Vac, 120Vac default
Output Voltage Range (L-L)	200 ~ 240Vac, 240Vac default

- Single-phase mode

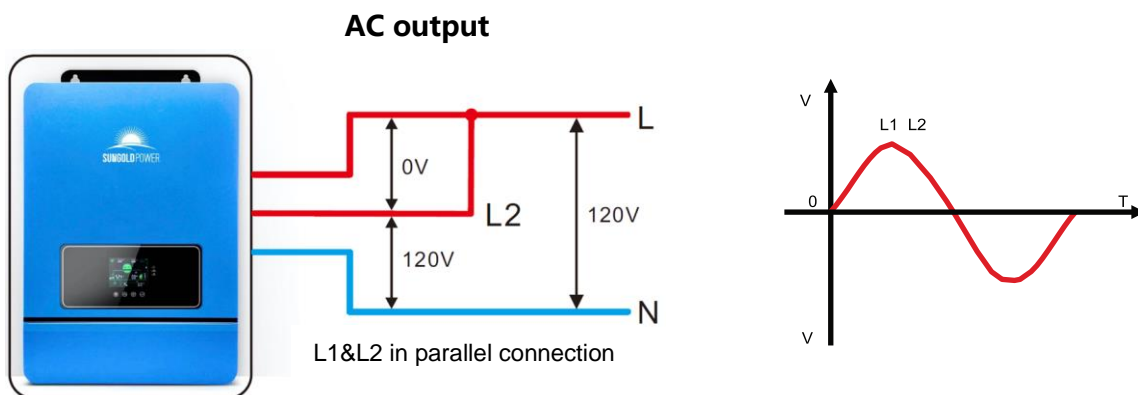

Items	Description
Applicable Model	SPH series
Output Voltage Range (L-N)	100 ~ 120Vac, 120Vac default

① NOTICE

- Users can change the output phase mode and output voltage by setup menu. Please read the chapter 5.2 Setting.
- Output phase mode corresponds parameter 39 , when option is 180 indicates split-phase, when option is 0 indicates single-phase.
- Output voltage corresponds parameter 38 , the output voltage can be set from 100V to 120V.

Split-phase Mode

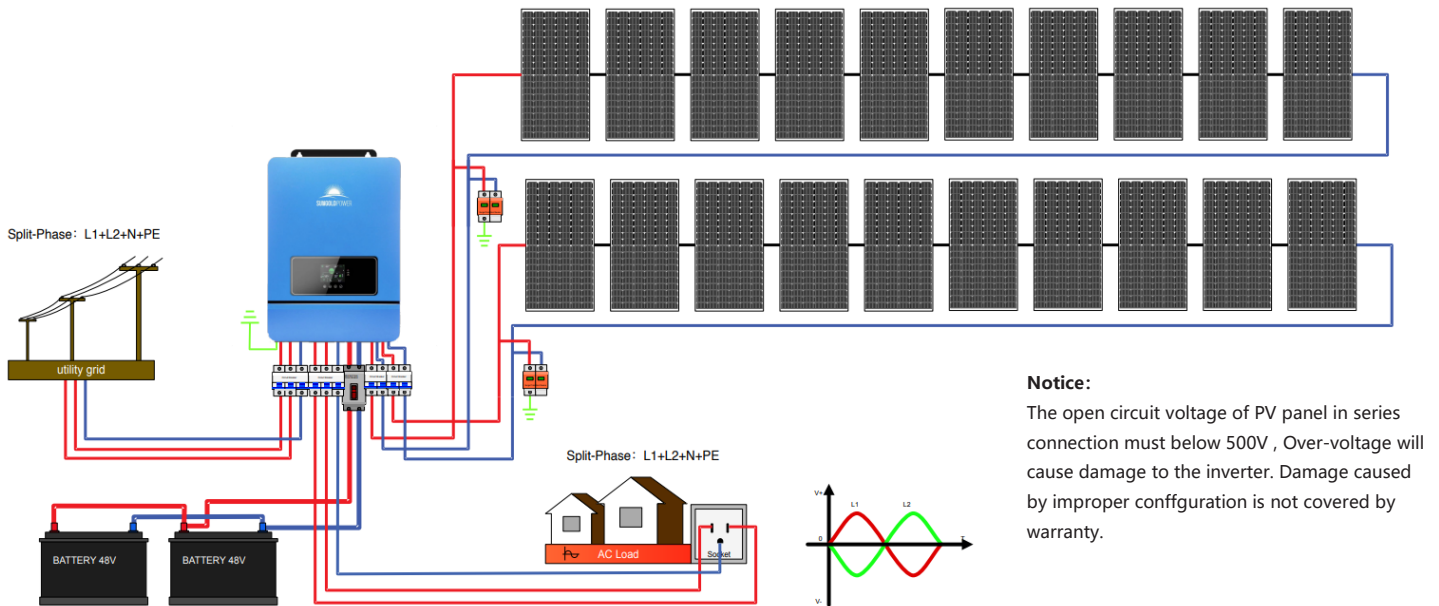

Single-phase Mode

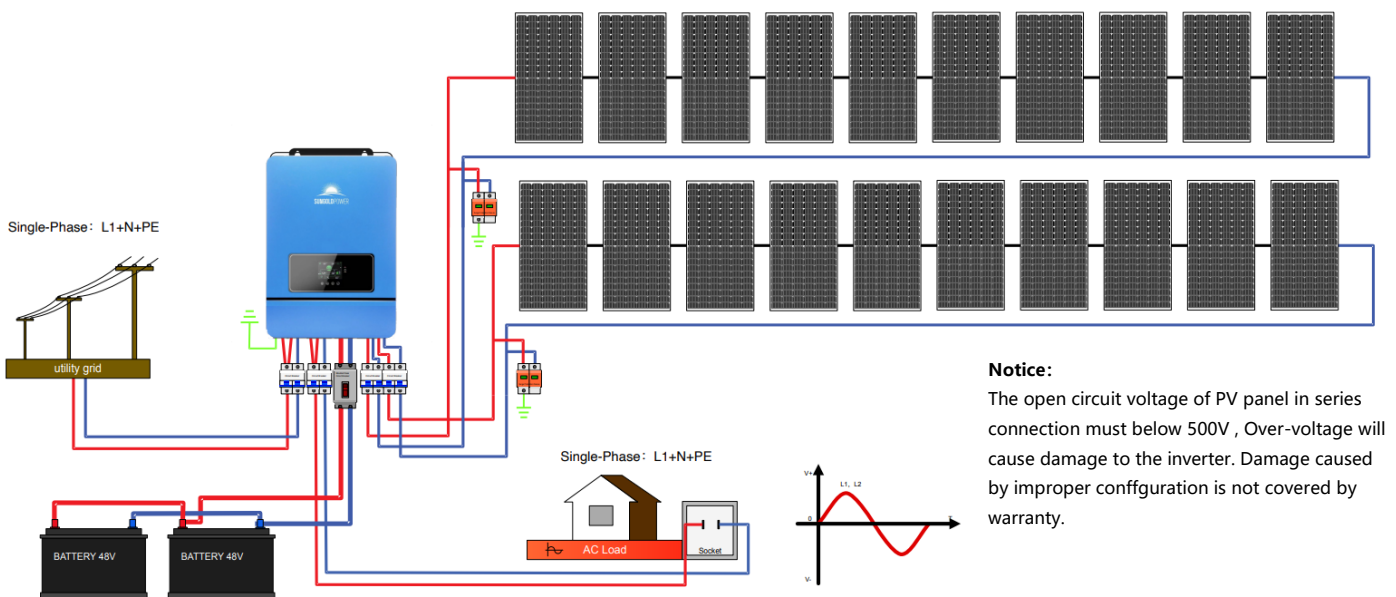

4.2、 Cable & circuit breaker requirement

• PV INPUT

Model	Cable Diameter	Max.PV Input Current	Circuit Breaker Spec
SPH8K48SP	5mm ² / 10 AWG	22A	2P-25A
SPH10K48SP	5mm ² / 10 AWG	22A	2P-25A

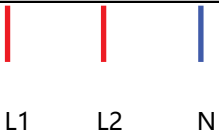
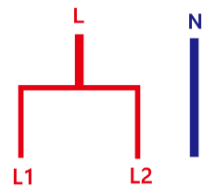
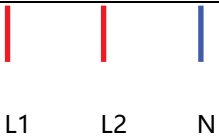
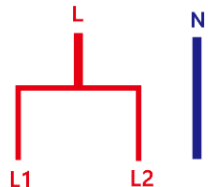

• AC INPUT

Model	Output Mode	Diagram	Max.Input Current	Cable diameter	Circuit Breaker Spec
SPH8K48SP	Split-phase	 L1 L2 N	63A(L1/L2/N)	13mm ² /6AWG (L1\L2\N)	3P-63A
	Single-phase	 L1 and L2 in same phase	63A(L1/L2) 126A(N)	13mm ² /6AWG(L1/L2) 26mm ² /3AWG(N)	2P-125A
SPH10K48SP	Split-phase	 L1 L2 N	63A(L1/L2/N)	13mm ² /6AWG (L1\L2\N)	3P-63A
	Single-phase	 L1 and L2 in same phase	63A(L1/L2) 126A(N)	13mm ² /6AWG(L1/L2) 26mm ² /3AWG(N)	2P-125A

• BATTERY

Model	Cable Diameter	Max.Battery Current	Circuit Breaker Spec
SPH8K48SP	34mm ² / 2 AWG	180A	2P-200A
SPH10K48SP	42mm ² / 1 AWG	220A	2P-250A

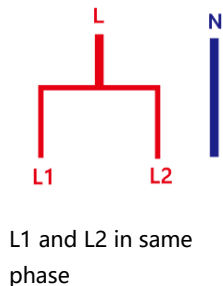
• AC OUTPUT

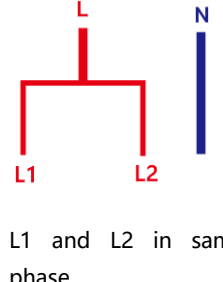
Model	Output Mode	Diagram	Max.Output Current	Cable diameter	Circuit Breaker Spec
SPH8K48SP	Split-phase	 L1 L2 N	42A (L1/L2/N)	13mm ² /6AWG (L1\L2\N)	3P-63A
	Single-phase	 L1 and L2 in same phase	42A (L1/L2) 84A(N)	13mm ² /6AWG(L1\ L2) 26mm ² /3AWG(N)	2P-125A
SPH10K48SP	Split-phase	 L1 L2 N	63A (L1/L2/N)	13mm ² /6AWG(L1\ L2\N)	3P-63A
	Single-phase	 L1 and L2 in same phase	63A (L1/L2) 126A(N)	13mm ² /6AWG (L1\L2) 26mm ² /3AWG(N)	2P-125A

NOTICE

• PV INPUT, AC INPUT, AC OUTPUT

1. Use a stripper to remove the 6~8mm insulation of the cable.
2. Fixing a ferrule at the end of the cable. (ferrule needs to be prepared by the user)

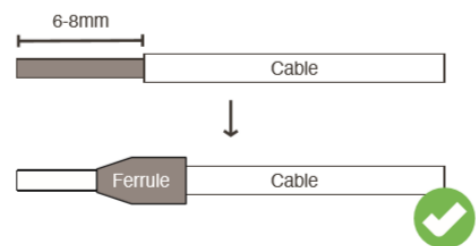

• BATTERY

1. Use a stripper to remove the 6~8mm insulation of the cable
2. Fixing cable lugs that supply with the box at the end of the cable.

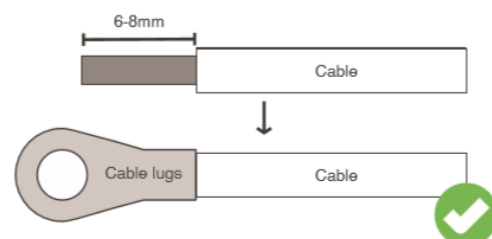

The wire diameter is for reference only. If the distance between the PV array and the inverter or between the inverter and the battery is long, using a thicker wire will reduce the voltage drop and improve the performance of the system.

4.3、 AC input & output connection

Connect the live, neutral and ground wires according to the cables' position and order shown in the diagram below.

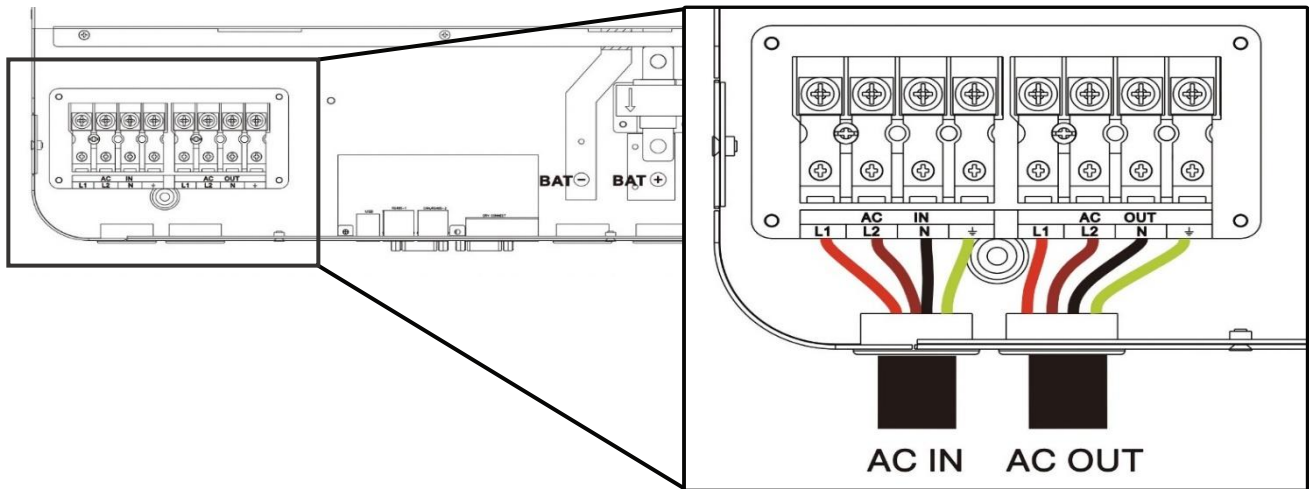

⚠ DANGER

- Before connecting AC inputs and outputs, the circuit breaker must be opened to avoid the risk of electric shock and must not be operated with electricity.
- Please check that the cable used is sufficient for the requirements, too thin, poor quality cables are a serious safety hazard.

4.4、 Battery Connection

Connect the positive and negative cable of the battery according to the diagram below.

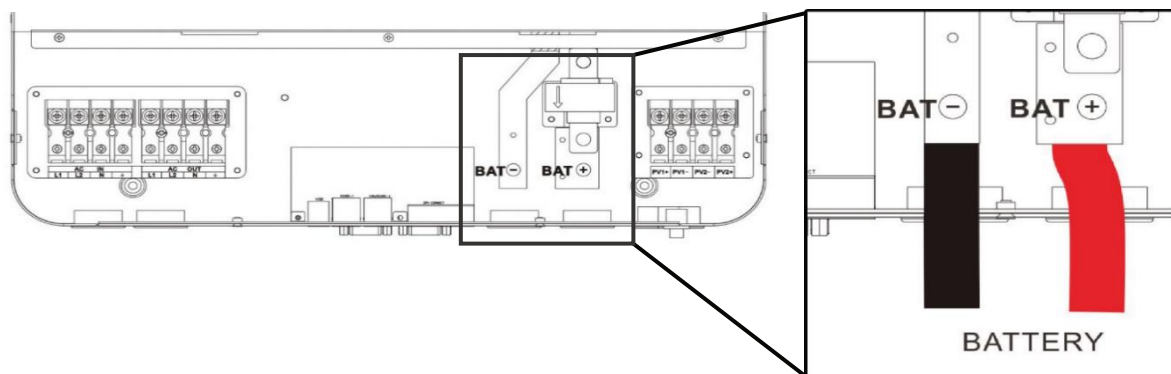

⚠ DANGER

- Before connecting battery, the circuit breaker must be opened to avoid the risk of electric shock and must not be operated with electricity.
- Make sure that the positive and negative terminals of the battery are connected correctly and not reversed, otherwise the inverter may be damaged.
- Please check that the cable used is sufficient for the requirements, too thin, poor quality cables are a serious safety hazard.

4.5、 PV connection

Connect the positive and negative wires of the two strings of PV according to the diagram below.

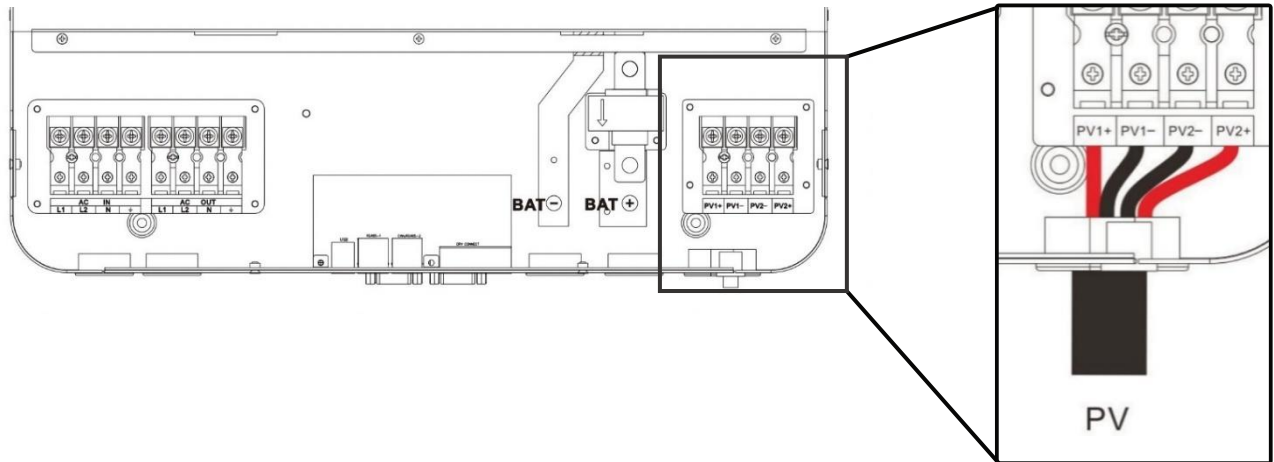

⚠ DANGER

- Before connecting PV, the circuit breaker must be opened to avoid the risk of electric shock and must not be operated with electricity.
- Please make sure that the open circuit voltage of the PV modules in series does not exceed the **Max.OpenCircuitVoltage** of the inverter (In the SPH series, this value is 500V), otherwise the inverter may be damaged.

4.6、 Dry contact connection

Use a small screwdriver to push back the direction indicated by the arrow, then insert the communication cable into the dry junction port. (Communication cable diameter 0.2~1.5mm²)

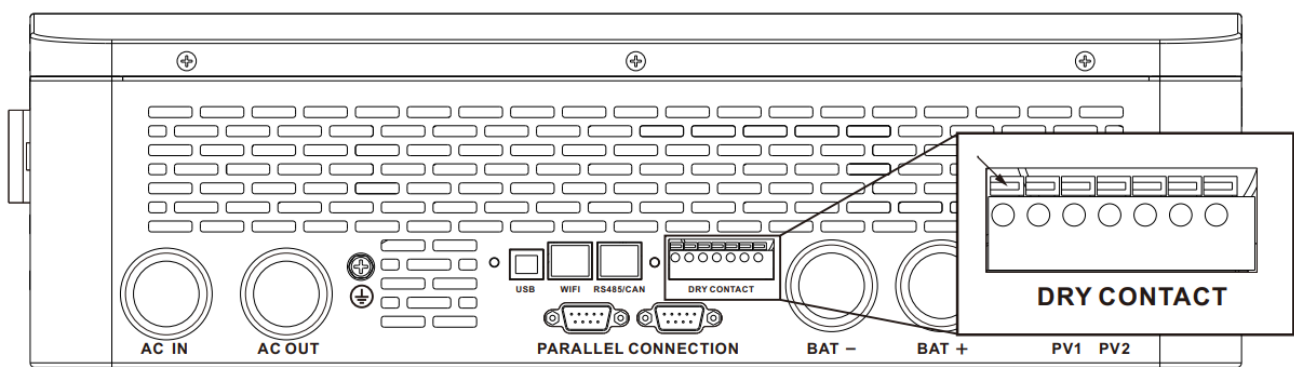

4.7、 Grounding connection

Please make sure the grounding terminal connect to the Grounding Bar.

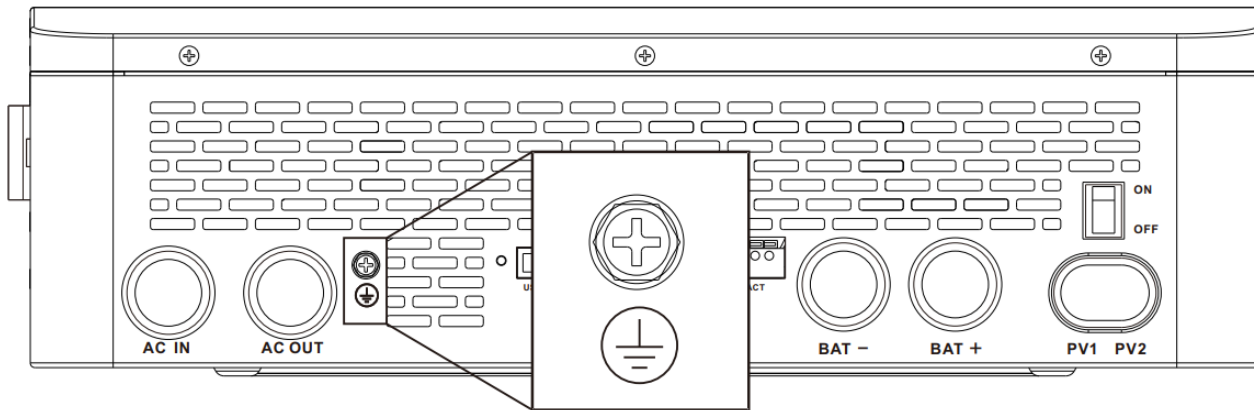

NOTICE

- The grounding cable should have a diameter of not less than 4 mm² and be as close as possible to the grounding point.

4.8、 Final assembly

After ensuring that the wiring is reliable and the wire sequence is correct, install the terminal protection cover in place.

4.9、 Start up the inverter

- **Step 1** : Close the circuit breaker of the battery.
- **Step 2**: Press the rocker switch on the bottom of inverter, the screen and indicators light up to indicate that the inverter has been activated.
- **Step 3**: Sequential close of the circuit breakers for PV, AC input and AC output.
- **Step 4**: Start the loads one by one in order of power from small to large.



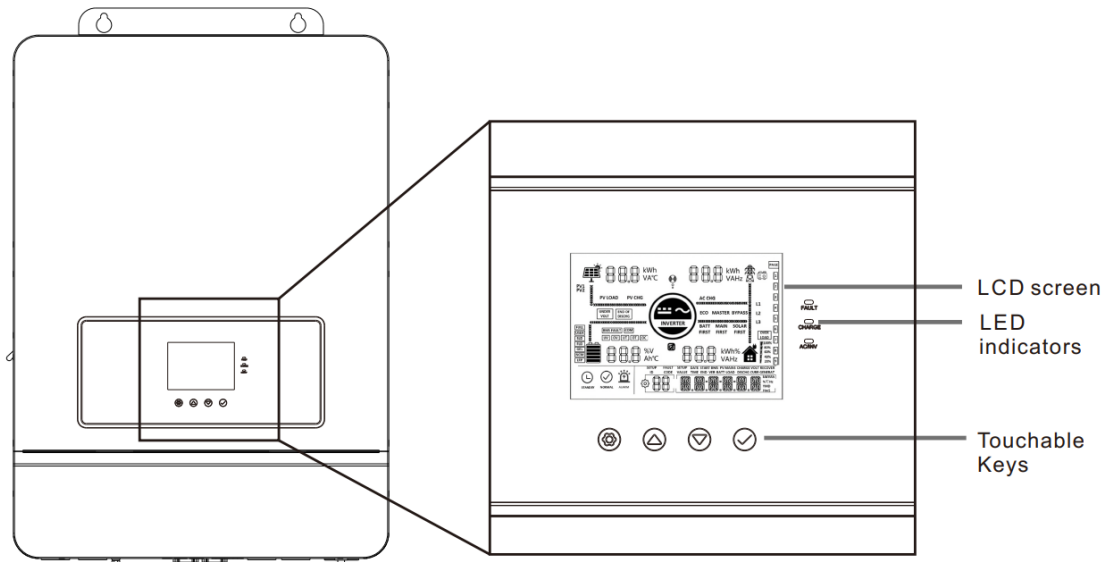

5. Operation

5.1、 Operation and display panel

The operation and display panel below includes 1 LCD screen, 3 indicators, 4 touchable keys.



- **Touchable Keys**

Touchable Keys	Description
	To enter/exit the setting menu
	To next selection
	To last selection
	To confirm/enter the selection in setting menu

- **LED Indicators**

Indicators	Color	Description
FAULT	Red	Flash: error occur
CHARGE	Green	Continued: charging complete
		Flash: charging
AC/INV	Yellow	Continued: utility grid by-pass output
		Flash: inverter output

• Display panel

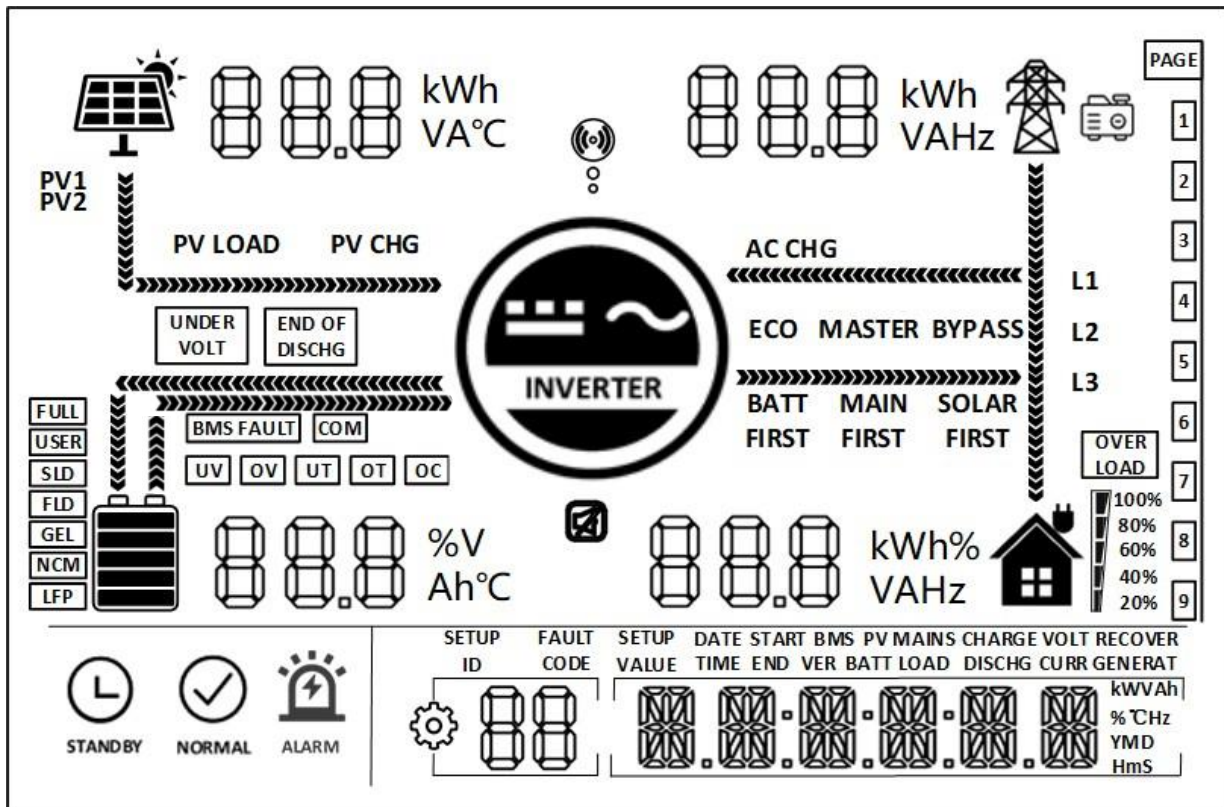

Icon	Description	Icon	Description
	Indicates the PV panel		Indicates the utility grid
	Indicates the battery		Indicates the generator
	Indicates the inverter is workin		Indicates the home load
	Indicates the inverter is communicating with data collector		Indicates the buzzer muted
	Indicates the direction of energy flow		
 STANDBY	Indicates the inverter is standby	 NORMAL	Indicates the inverter is working normally
 ALARM	Indicates error occur		Indicates setting

Icon	Description	Icon	Description
	Indicates load power 80%~100%		Indicates battery SOC 80%~100%
	Indicates load power 60%~79%		Indicates battery SOC 60%~79%
	Indicates load power 40%~59%		Indicates battery SOC 40%~59%
	Indicates load power 20%~39%		Indicates battery SOC 20%~39%
	Indicates load power 5%~19%		Indicates battery SOC 5%~19%
UNDER VOLT	Indicates battery under-voltage	END OF DISCHG	Battery over discharge
OVER LOAD	Indicates over-load	BMS FAULT	Indicates BMS fault
COM	Indicates system communication erro	UV	Indicates system under-voltage
OV	Indicates system over-voltage	UT	Indicates system undertemperature
OT	Indicates system overtemperatur	OC	Indicates system over-current
FULL	Indicates battery is full	USER	Indicates user defined battery
SLD	Indicates sealed lead-acid battery	FLD	Indicates flooded lead-acid battery
GEL	Indicates gel lead-acid battery	NCM	Indicates ternary li-ion battery
LFP	Indicates LFP li-ion battery	ECO	Indicates energy-saving mode
PV LOAD	Indicates PV energy is carrying the load	PV CHG	Indicates PV energy is charging the battery
AC CHG	Indicates AC IN energy is charging the battery	MAIN FIRST	Indicates the inverter output mode is mains power first
BYPASS	Indicates the inverter output mode is bypass	SOLAR FIRST	Indicates the inverter output mode is solar first
BATT FIRST	Indicates the inverter output mode is battery first		

• **View real-time data**

In the main screen, press the UP / DOWN keys to view the real-time data of the inverter during operation.

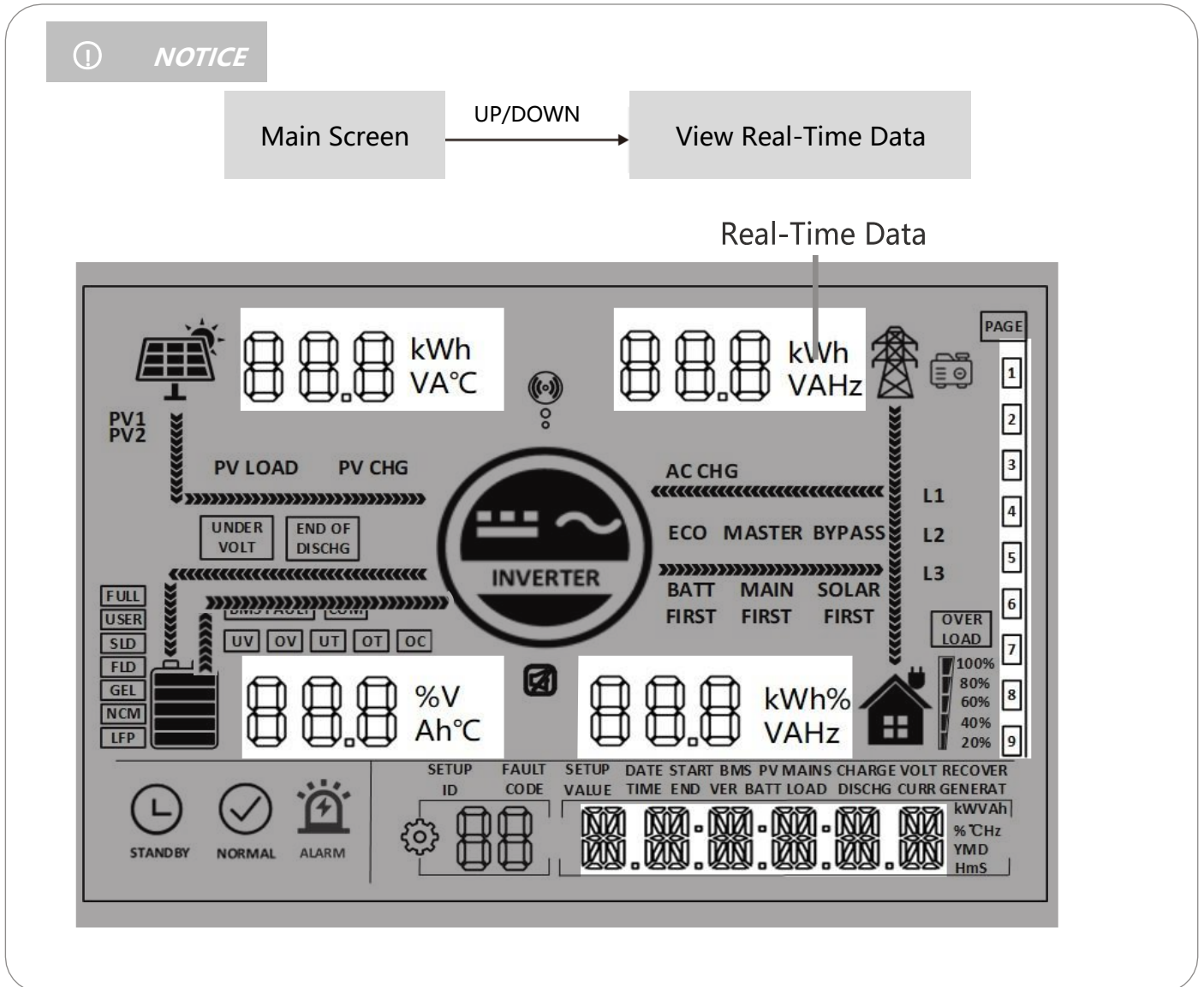

Page	PV side	BAT side	AC IN side	LOAD side	General
1	PV voltage	Batt Voltage	AC in voltage	Single phase voltage	Current Time
2	PV current	Batt Current	AC in current	Single phase Current	Current Date
3	PV power	Batt Voltage	Total AC charging power	Single phase active power	PV Total kWh
4	PV today kWh	Batt Current	Today AC charging kWh	Single phase apparent power	Load Total kWh
5	PV side heat sink temperature	INV Heat Sink Temperature	AC frequency	AC output frequency	RS485 Address
6	PV rated voltage	Batt Rated Voltage	Busbar voltage	AC output rated power	Soft Version
7	Max. PV charging current	Max. Batt charging current	Max. AC charging Current	Total AC output active power	/
8			/	Total AC output apparent power	/

5.2、 Setting

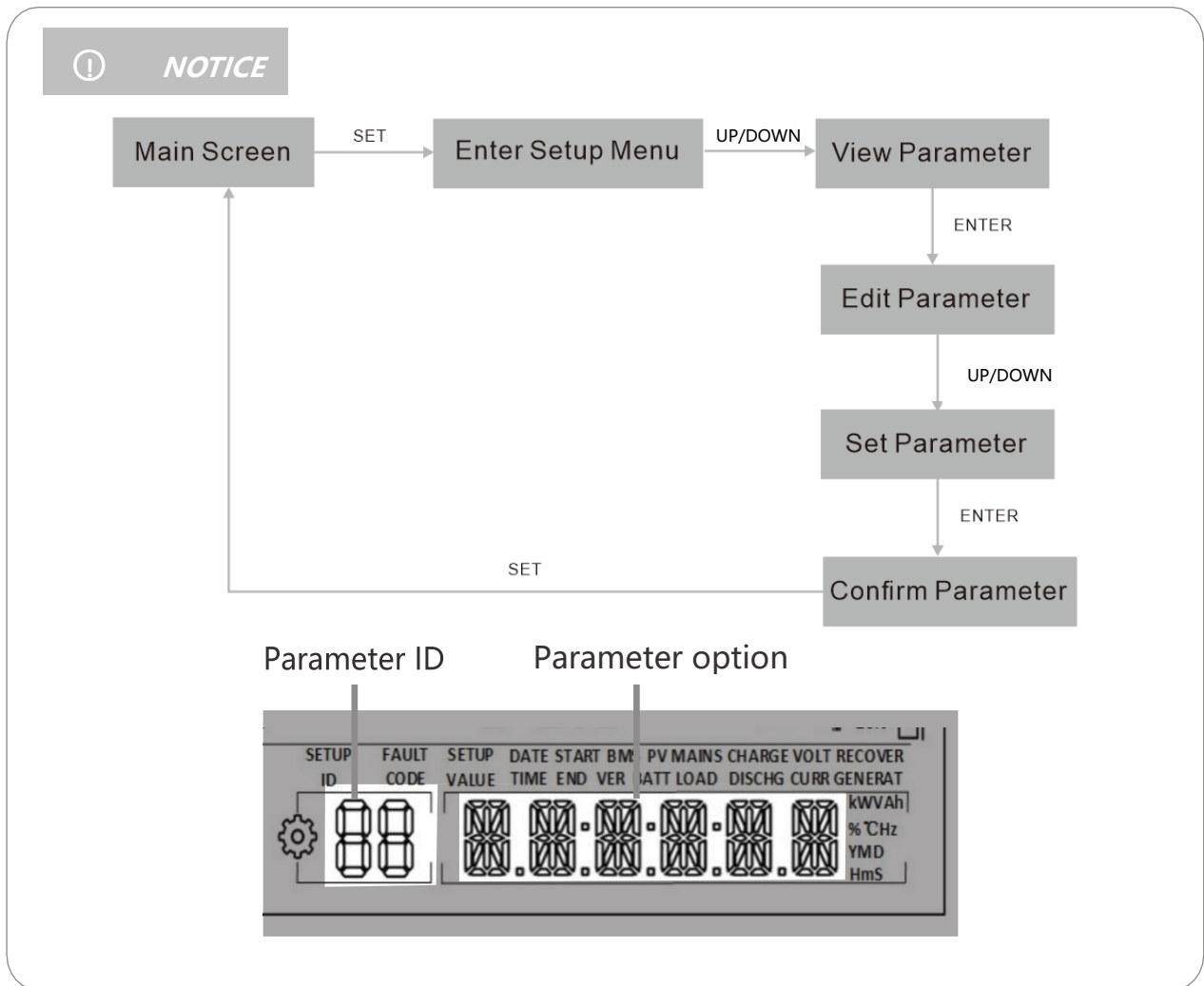

ID	Parameter Meaning	Options	Description
00	Exit	ESC	Exit the setup menu.
01	AC output source priority	UTI default	Utility at first priority, utility and solar provide power to load at the same time when solar is available, battery will provide power to load only when utility power is not available.
		SbU	Solar power and battery at first priority,Utility will provide power to load when solar power is not available and the battery voltage below parameter [04] value.
		SOL	Solar power at first priority, Utility will provide power to load when solar power is not available and the battery voltage below parameter [04] value .
02	AC output frequency	50.0	AC output frequency will adaptive utility frequency in bypass mode.Otherwise the output will follow the preset value.
		60.0 default	

ID	Parameter Meaning	Options	Description
03	AC input voltage range	UPS default	When output range is 120/110V, input voltage range 90~140V
		APL	When output range is 100/105V, input voltage range 85~140V
04	Voltage point of battery switch to utility	43.6 default	When parameter1= SBU=SOL, output source will switch to utility from battery when the battery voltage below the preset value. Setting range:40~60V
05	Voltage point of utility switch to battery	56.8 default	When parameter 1=SBU/SOL, output source will switch to battery from utility when the battery voltage above the preset value. Range:40~60V
06	Battery charging mode	SNU default	Solar and utility charging the battery at the same time, solar at the first priority, utility power as a supplement when solar power is not sufficient. Notice: Solar and utility charging the battery at the same time only in bypass mode, only solar charging can be used when the invert circuit is in operation
		CUB	Utility is the first priority in charging, Solar charging the battery only when utility is not available.
		CSO	Solar is the first priority in charging, Utility charging the battery only when solar is not available
		OSO	Only solar charging the battery.
07	Battery charging current	60 default	SPH8K48SP current setting range:0~180A.
			SPH10K48SP current setting range:0~200A.
08	Battery type	USER	User-defined, user can set all battery parameter.
		SLd	Sealed lead-acid battery.
		FLd	Flooded lead-acid battery.
		GEL default	Gel lead-acid battery.
		L14/ L15/ L16	LFP li-ion battery, L14\L15\L16 corresponds battery cells number in series.
N13/ N14	Ternary li-ion battery.		
09	Battery bulk charging voltage	57.6 default	Setting range:48V~58.4V, increment of each click is 0.4V, parameter can be set only when battery type is USER and L14/15/16,N13/14
10	Battery bulk charging delay time	120 default	Indicates the duration when battery voltage reached parameter 09 value in bulk charging procession, Setting range: 5min~900min, increment of each click is 5min, parameter can be set only when battery type is USER and L14/15/16,N13/14

ID	Parameter Meaning	Options	Description
11	Battery float charging voltage	55.2 default	Setting range: 48V~58.4V, parameters cannot be set only after successful BMS communication.
12	Battery overdischarge voltage (delay off	42 default	When the battery voltage falls below this voltage point and parameter 13 value is reached, the inverter output will be switched off. Setting range: 40V~48V, increment of each click is 0.4V, parameter can be set only when battery type is USER and L14/15/16,N13/14
13	Battery overdischarge voltage delay time	5 default	Indicates the duration when battery voltage reached parameter 12 value in over-voltage procession. Setting range: 5s~50s, increment of each click is 5s, parameter can be set only when battery type is USER and LFP14/15/16,NCM13/14
14	Battery undervoltage alarm	44 default	When the battery voltage falls below this voltage point, alarm will be displayed on the screen and indicator. Setting range: 40V~52V, increment of each click is 0.4V, parameter can be set only when battery type is USER and L14/15/16,N13/14
15	Battery undervoltage limit voltag	40 default	When the battery voltage falls below this voltage point, the inverter output is switched off immediately. Setting range is 40V~52V, increment of each click is 0.4V, parameter can be set only when battery type is USER and L14/15/16,N13/14
16	Battery equalization charging	dIS	Disable equalization charging.
		ENA default	Enable equalization charging, parameter can be set only when battery type is FLd\SLd\USER
17	Battery equalization charging voltage	58	Setting range: 48V~58V, increment of each click is 0.4V, parameter can be set only when battery type is FLd\SLd\USER
18	Battery equalization charging duration	120	Setting range: 5min~900min, increment of each click is 5min, parameter can be set only when battery type is FLd\SLd\USER
19	Battery equalization charging delay time	120	Setting range: 5min~900min, increment of each click is 5min, parameter can be set only when battery type is FLd\SLd\USER
20	Battery equalization charging interval	30	Setting range: 0~30 days, increment of each click is 1 day, parameter can be set only when battery type is FLd\SLd\USER
21	Battery equalization charging stop-start	dIS default	Stop equalization charging immediately.
		ENA	Start equalization charging immediately
22	Power saving mode	dIS default	Disable power saving mode
		ENA	Enable power saving mode, When the load power below 50W, the inverter output will switch off after a 5min delay . When the load is more than 50W, the inverter automatic restart

ID	Parameter Meaning	Options	Description
23	Over-load restart	dIS	When overload occurs and the output is switched off, the machine will not restart.
		ENA default	When overload occurs and the output is switched off, the machine will restart after a delay of 3 minutes. After it reaches 5 cumulative time, the machine will not restart automatically.
24	Over-temperature restart	dIS	When over temperature occurs and the output is switched off, the machine will not restart.
		ENA default	When overload occurs and the output is switched off, the machine will restart when the temperature drops.
25	Buzzer alarm	dIS	Disable buzzer alarm.
		ENA default	Enable buzzer alarm.
26	Power source switching reminder	dIS	Disable reminder when the status of the input power source changes.
		ENA default	Enable reminder when the status of the input power source changes.
27	Inverter overload switch to bypass	dIS	Disable switch to the bypass when the inverter is overload
		ENA default	Enable switch to the bypass when the inverter is overload.
28	Max. utility charging current	60 default	SPH8K48SP, setting range: 0~100A.
			SPH10K48SP, setting range: 0~120A.
30	RS485 address	Id:1	RS485 address setting range: 1~254.
32	RS485 communication	SLA default	Enabling PC and remote monitoring protocols
		485	Enabling BMS communication based on RS485
		CAN	Enabling BMS communication based on CAN
33	BMS communication	When item 32 is set to 485 or CAN, the corresponding communication protocol must be selected in item 33	
		PAC=PACE, RDA=Ritar, AOG=ALLGRAND BATTERY, OLT=OLITER, HWD=SUNWODA, DAQ=DAKING, WOW=SRNE, PYL=PYLONTECH UOL=WEILAN	
34	Feed back & hybrid output function	dIS default	Disable this function.
		MIX LOD	When parameter 1=UTI ,the solar energy is prioritised to charge the batteries and any excess energy will be used to power the load. With an anti-backflow function, the PV energy is not feed back into the grid.
		ON GRD	When parameter 1=UTI ,solar energy will feed back into the grid when battery is full or disconnected.
35	Battery under voltage recover point	52	Battery recover discharge from under voltage protection when voltage above this value. Setting range: 44V~54V.
37	Battery full recharge voltage point	52	Inverter stops charging when the battery is full. Inverter resumes charging when the battery voltage below this value. Setting range: 44V~54V.

ID	Parameter Meaning	Options	Description
38	AC output voltage	120	Setting range: 100/105/110/120Vac
40	1st slot start charging	00:00:00	Setting range: 00:00:00-23:59:00
41	1st slot end charging	00:00:00	Setting range: 00:00:00-23:59:00
42	2nd slot start charging	00:00:00	Setting range: 00:00:00-23:59:00
43	2nd slot end charging	00:00:00	Setting range: 00:00:00-23:59:00
44	3rd slot start charging	00:00:00	Setting range: 00:00:00-23:59:00
45	3rd slot end charging	00:00:00	Setting range: 00:00:00-23:59:00
46	Time slot charging function	dIS default	Disable this function
		ENA	Enable this function, AC output source mode will switch to SBU, utility charging the battery and carry load only in charging time slot which user set or the battery is under voltage.
47	1st slot start discharging	00:00:00	Setting range: 00:00:00-23:59:00
48	1st slot end discharging	00:00:00	Setting range: 00:00:00-23:59:00
49	2nd slot start discharging	00:00:00	Setting range: 00:00:00-23:59:00
50	2nd slot end discharging	00:00:00	Setting range: 00:00:00-23:59:00
51	3rd slot start discharging	00:00:00	Setting range: 00:00:00-23:59:00
52	3rd slot end discharging	00:00:00	Setting range: 00:00:00-23:59:00
53	Time slot discharging function	dIS default	Disable this function.
		ENA	Enable this function, AC output source mode will switch to UTI , battery discharging only in discharging time slot which user set or utility is not available.
54	Local date	00:00:00	YY/MM/DD.Setting range: 00:01:01-99:12:31
55	Local time	00:00:00	Setting range: 00:00:00-23:59:59
57	Stop charging current	2	Charging stops when the charging current is less than the set value (unit:amp)

ID	Parameter Meaning	Options	Description
58	Discharging alarm SOC	15	Triggers an alarm when the battery SOC is less than the set value (unit:%)
59	Discharging cutoff SOC	5	Stops discharging when the battery SOC is less than the set value (unit:%)
60	Charging cutoff SOC	100	Stops charging when the battery SOC is touch the set value (unit:%)
61	Switching to utility SOC	10	Switch to utility power when the battery SOC is less than this setting (unit:%)
62	Swithing to inverter SOC	100	Switches to inverter output mode when SOC is greater than this setting (unit:%)
63	N-PE bonding automatic switching function	dIS default	Allow automatic switching of N-PE bonding
		ENA	Prohibit automatic switching of N-PE bondin
68	AC output phase mode	0	0 stands for single-phase mode. Assume parameter 38=120V.The phase difference of L1-L2 is 0 degree, L1/L2 in parallel connection, therefore L1-N/L2-N voltage is 120V.Setting allowed only when output is switched off.
		180 default	180 stands for split-phase mode. Assume parameter 38=120V, The phase difference of L1-L2 is 180 degree, therefore L1-N/L2-N voltage is 120V, L1-L2 voltage is $120*2=240V$.Setting allowed only when output is switched off.

5.3、 AC output mode

The AC output mode corresponds to parameter setting item 01 and 34, which allows the user to set the AC output power source manually.

- **Utility Priority Output 01 UTI (default)**

Utility at first priority, utility and solar provide power to load at the same time when solar is available, battery will provide power to load only when utility power is not available. **(Priority: utility>solar>battery)**

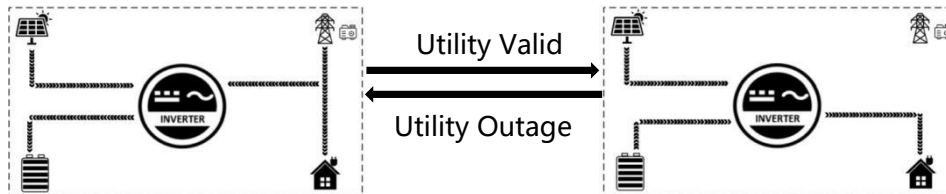

- **Solar and Utility Hybrid Output 34 MIX LOD**

In UTI mode, when not connected to the battery or when the battery is full, the solar and the utility supply power to the load at the same time. **(Priority: solar>utility>battery)**

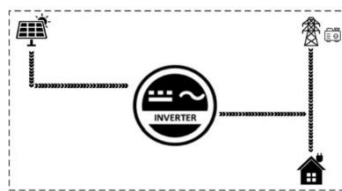

Battery disconnected

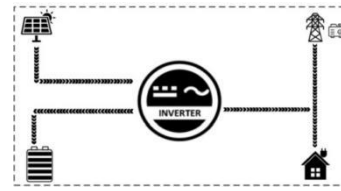

Battery Full

- **Solar Priority Output 01 SOL**

Solar provides power to the loads as first priority. If solar is not sufficient or not available, the utility will be used as a supplement to provide power to the loads. This mode maximises solar energy while maintaining battery power and is suitable for areas with relatively stable power grids. **(Priority: solar>utility>battery)**

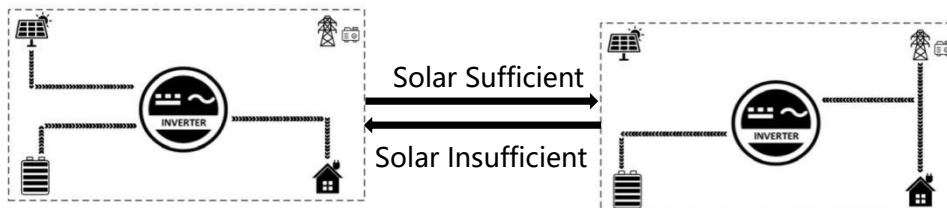

- **Inverter Priority Output 01 SbU**

Solar provides power to the loads as first priority. If solar is not sufficient or not available, the battery will be used as a supplement to provide power to the loads. When the battery voltage reaches the value of parameter 04 (Voltage point of battery switch to utility) will switch to utility to provide power to the load, This model makes maximum use of DC energy and is used in areas where the grid is stable. **(Priority: solar>battery>utility)**

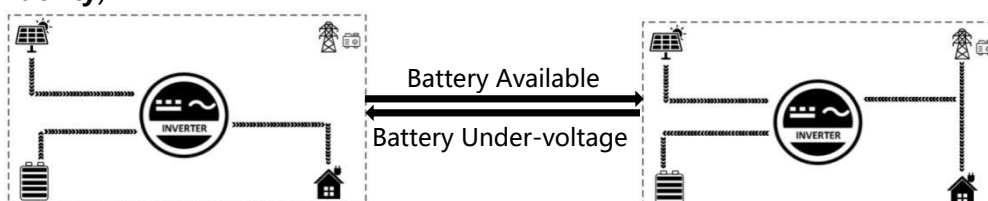

5.4、 Battery charging mode

The charging mode corresponds to parameter setting item 06, which allows the user to set the charging mode manually.

- **Hybrid Charging SNU (default)**

Solar and utility charging the battery at the same time, solar at the first priority, utility power as a supplement when solar power is not sufficient. This is the fastest way to charge and is suitable for areas with low power supply, providing customers with sufficient back-up power. **(Source priority: solar>utility)**

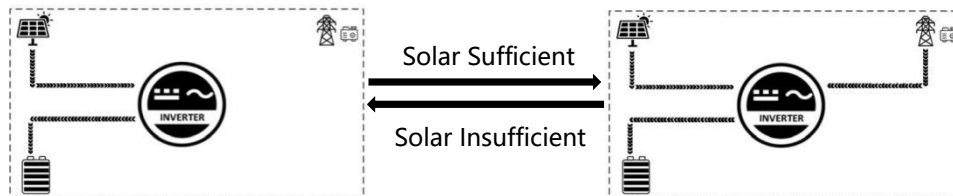

- **Utility Priority Chargin CUb**

The utility power gives priority to charging the battery, and PV charging is only activated when the utility power is not available. **(Source priority: utility>solar)**

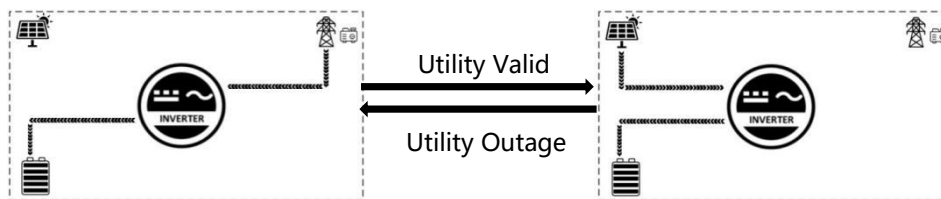

- **Solar Priority Charging CSO**

Solar priority charging, with utility charging only activated when the solar fails. By making full use of solar power during the day and switching to utility charging at night, battery power can be maintained and is suitable for applications in areas where the grid is relatively stable and electricity prices are more expensive. **(Source priority: solar>utility)**

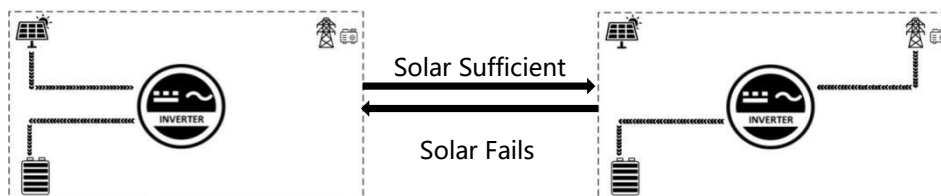

- **Only Solar Chargin OSO**

Solar charging only, no mains charging is activated. This is the most energy-efficient method, with all the battery power coming from solar energy, and is usually used in areas with good radiation conditions.

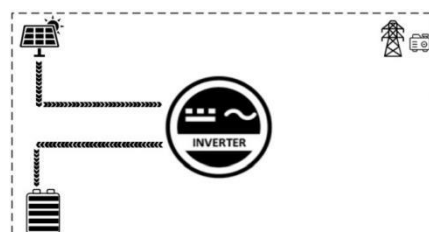

5.5、Time-slot charging/discharging function

The SPH series is equipped with a time-slot charging and discharging function, which allows users to set different charging and discharging periods according to the local peak and valley tariffs, so that the utility power and PV energy can be used rationally.

When mains electricity is expensive, the battery inverter is used to carry the load; when the mains electricity is cheap, the mains electricity is used to carry the load and charge, which can help customers to save electricity costs to the greatest extent.

The user can turn on/off the time-slot charging/discharging function in setup menu parameter 46 and 53, and set charging and discharging slot in parameter 40-45, 47-52. Below are examples for users to understand the function.

NOTICE

Before using this function for the first time, please set the local time in parameter items 54, 55, then the user can set the corresponding time slot according to the local peak and valley tariff charges.

Peak-Valley Electricity Tariff

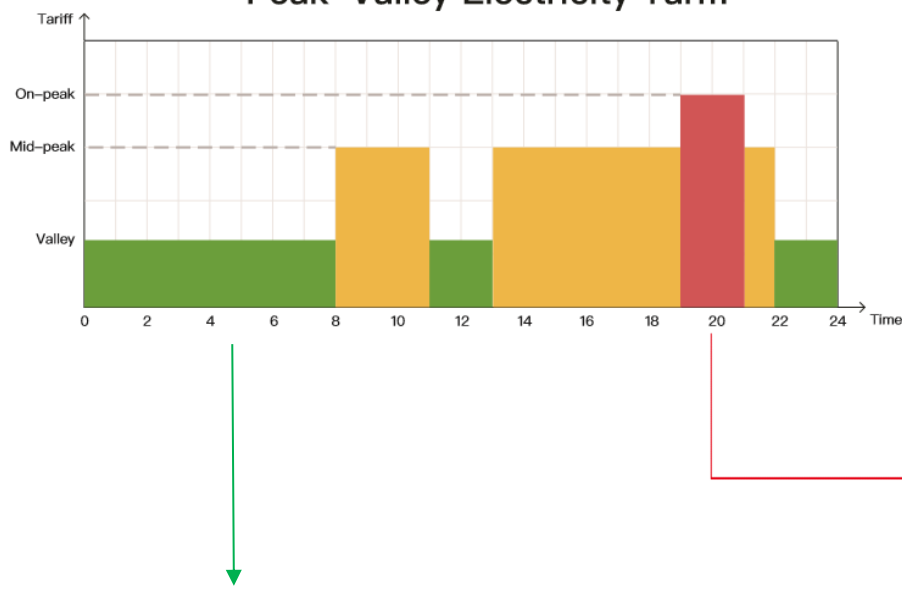

Time-slot Utility Charging/Carrying Function



With 3 definable periods, the user can freely set the mains charging/carrying time within the range of 00:00 to 23:59. During the time period set by the user, if PV energy is available, PV energy will be used first, and if PV energy is not available or insufficient, utility energy will be used as a supplement.

Time-slot Battery Discharging Function



With 3 definable time periods, users can freely set the battery discharge time within the range of 00:00 to 23:59. During the time period set by the user, the inverter will give priority to the battery inverter to carry the load, and if the battery power is insufficient, the inverter will automatically switch to mains power to ensure stable operation of the load.

5.6、 Battery parameter

• Lead-acid battery

Parameter/Battery type	Sealed	Gel	Flooded	User-defined
	SLd	GEL	FLd	USE
Over-voltage cut-off voltage	60V	60V	60V	60V
Equalization charging voltage	58V	56.8V	58V	40~60V settable
Bulk charging voltage	57.7V	56.8V	57.6V	40~60V settable
Float charging voltage	55.2V	55.2V	55.2V	40~60V settable
Under-voltage alarm voltage	44V	44V	44V	40~60V settable
Under-voltage cut-off voltage	42V	42V	42V	40~60V settable
Discharging limit voltage	40V	40V	40V	40~60V settable
Over-discharge delay time	5s	5s	5s	1~30s settable
Equalization charging duration	120m	-	120min	0~600min settable
Equalization charging interval	30d	-	30d	0~250d settable
Bulk charging duration	120m	120m	120m	10~600m settable

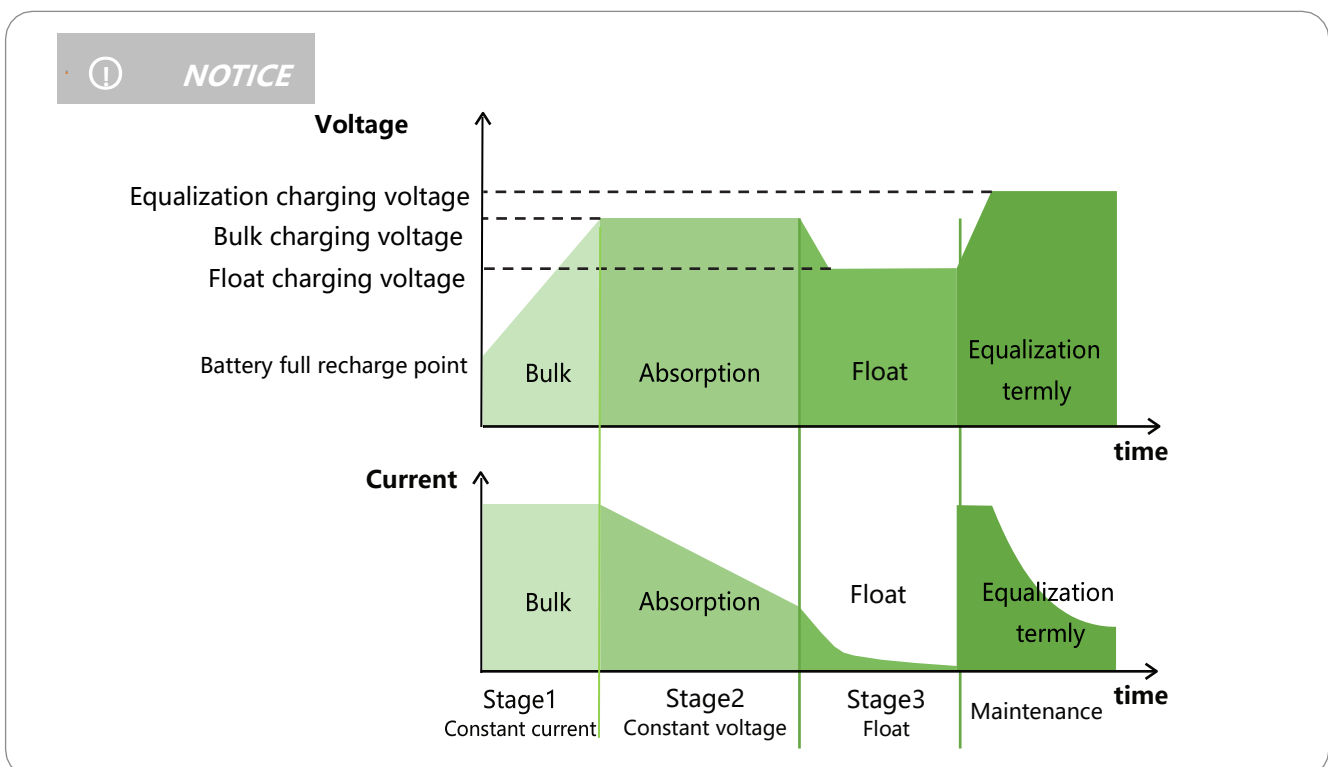

- **Li-ion batter**

Parameter/Battery type	Ternary		LFP			Userdefined
	N13	N14	L16	L15	L14	USE
Over-voltage cut-off voltage	60V	60V	60V	60V	60V	60V
Equalization charging voltage	-	-	-	-	-	40~60V settable
Bulk charging voltage	53.2V	57.6V	56.8V	53.2V	49.2V	40~60V settable
Float charging voltage	53.2V	57.6V	56.8V	53.2V	49.2V	40~60V settable
Under-voltage alarm voltage	43.6V	46.8V	49.6V	46.4V	43.2V	40~60V settable
Under-voltage cut-off voltage	38.8V	42V	48.8V	45.6V	42V	40~60V settable
Discharging limit voltage	36.4V	39.2V	46.4V	43.6V	40.8V	40~60V settable
Over-discharge delay time	30s	30s	30s	30s	30s	1~30s settable
Equalization charging duration	-	-	-	-	-	0~600min settable
Equalization charging interval	-	-	-	-	-	0~250d settable
Bulk charging duration	120min settable	120min settable	120min settable	120 m settable	120 m settable	10~600min settable

6. Communication

6.1、 Overview

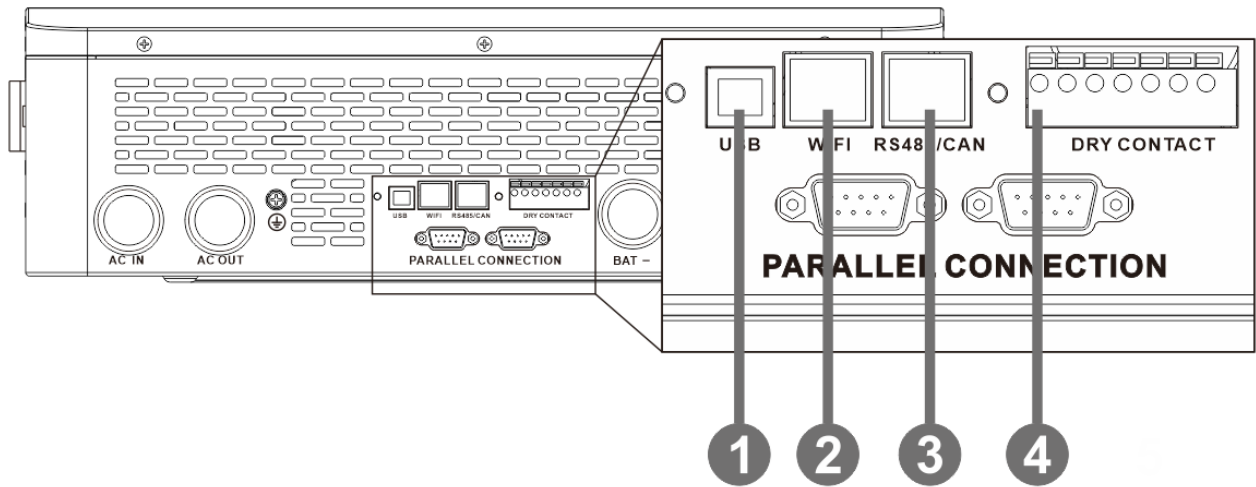

1	USB-B port	2	WIFI port
3	RS485/CAN port	4	Dry contact port

6.2、 USB-B port

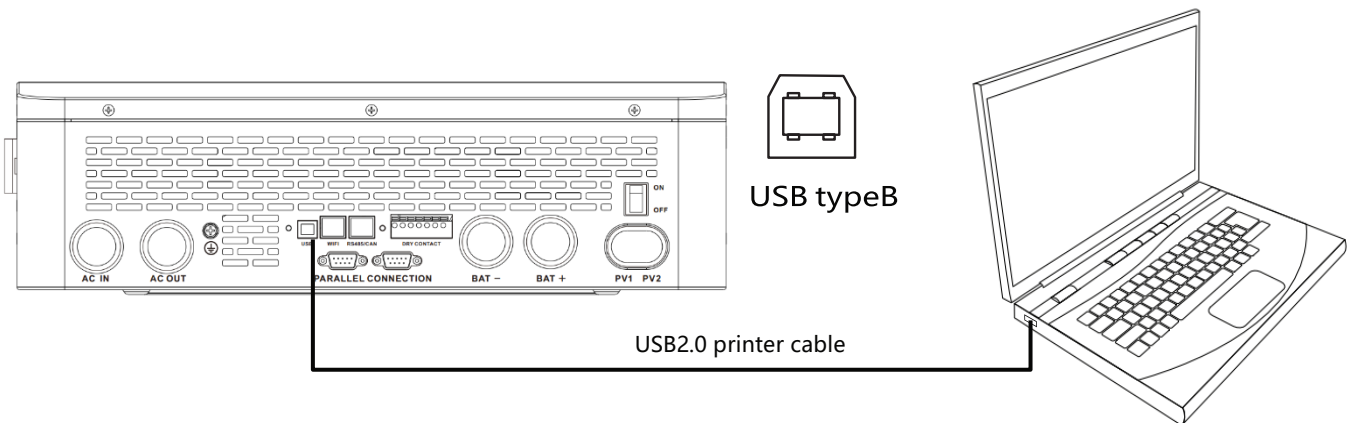

The user can read and modify device parameters through this port by using the host software. Please contact us for the host software installation package if you require one

6.3、WIFI port

The WIFI port is used to connect to the Wi-Fi/GPRS data acquisition module, which allows the user to view the operating status and parameters of the inverter via the mobile phone APP.

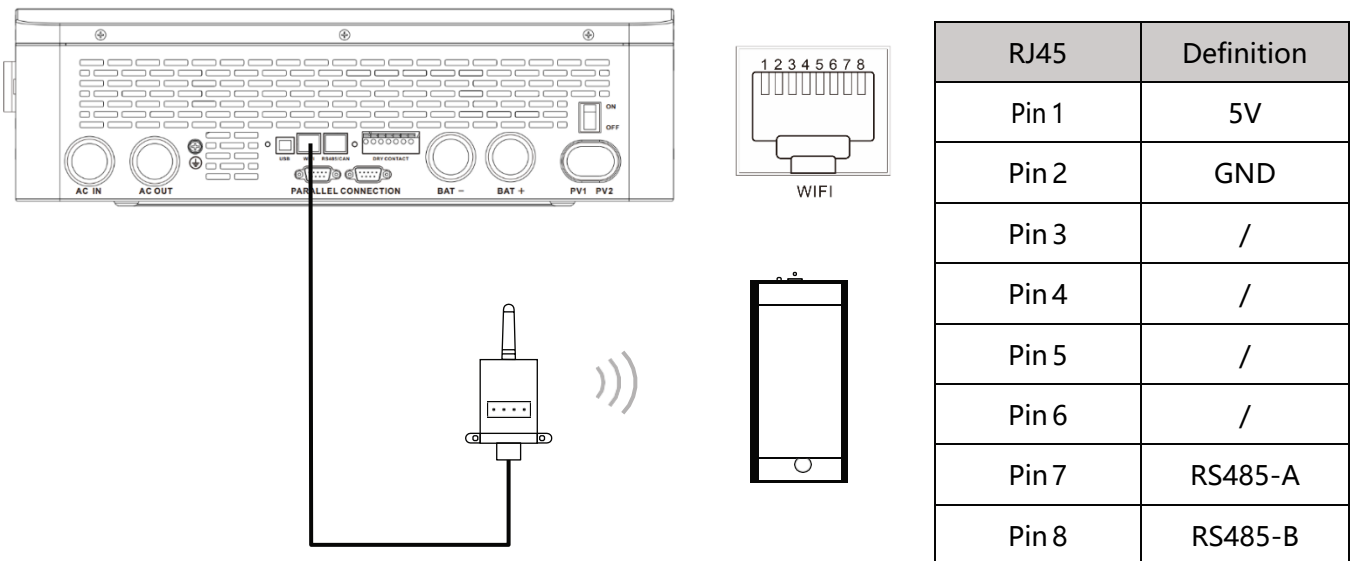

NOTICE

The Wi-Fi/GPRS data acquisition module need to be purchased separately. User can scan the QR code to download the mobile APP.



6.4、RS485/CAN port

The RS485/CAN port is used to connect to the BMS of Liion battery.

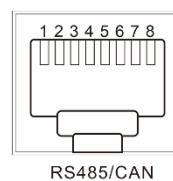

RJ45	定义
Pin 1	5V
Pin 2	GND
Pin 3	/
Pin 4	CANH
Pin 5	CANL
Pin 6	/
Pin 7	RS485-A
Pin 8	RS485-B

NOTICE

If you need the inverter to communicate with the lithium battery BMS, please contact us for the communication protocol or to upgrade the inverter to the corresponding software program. If you use a normal RJ45 network cable, please check the pin assignment, pin 1 & pin 2 usually need to be cut off for normal use.

6.5、 Dry contact

Dry contact port with 4 functions:

1. Remote switch on/off ;
2. Switching signal output;
3. Battery temperature sampling
4. Generator remote start/ stop

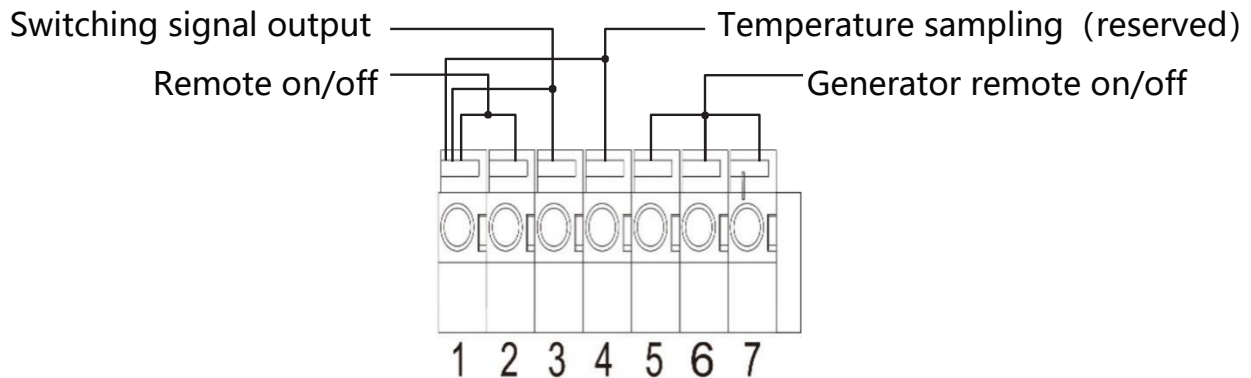

Function	Description
Remote switch on/off	When pin 1 is connected with pin 2, the inverter will switched off the AC output. When pin1 is disconnected from pin2, the inverter outputs normally.
Switching signal output	When the voltage of battery reaches the under-voltage limit voltage (parameter 15) , pin 3 to pin 1 voltage is 0V, When the battery charging/discharging normally pin 3 to pin 1 voltage is 5V.
Temperature sampling (reserved)	Pin 1 & Pin 4 can be used for battery temperature sampling compensation.
Generator remote start/stop	When the voltage of battery reaches the under-voltage alarm voltage (parameter 14) or voltage point of utility switch to battery (parameter 04), pin 6 to pin 5 normal open, pin 7 to pin 5 normal close. When the voltage of battery reaches the voltage point of battery switch to utility (parameter 05) or battery is full. pin 6 to pin 5 normal close, pin 7 to pin 5 normal open. (Pin 5/6/7 outputs 125Vac/1A, 230Vac/1A, 30Vdc/1A)



NOTICE

If you need to use the remote start/stop function of the generator with dry contact, ensure that the generator has ATS and supports remote start/stop.

7. Fault and Remedy

7.1. Fault code

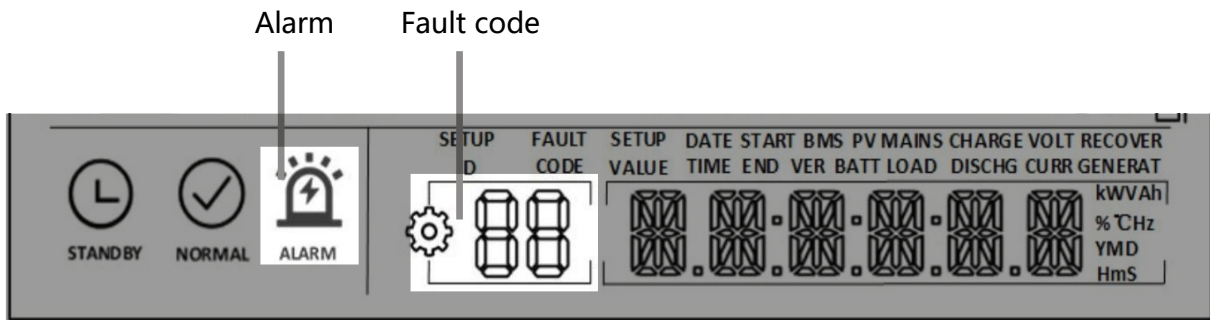

Fault Code	Meaning	Does it Affect the outputs	Instructions
01	BatVoltLow	Yes	Battery under-voltage alarm
02	BatOverCurrSw	Yes	Battery discharge over-current, software protection
03	BatOpen	Yes	Battery disconnected alarm
04	BatLowEod	Yes	Battery under-voltage stop discharging alarm
05	BatOverCurrHw	Yes	Battery over-current hardware protection
06	BatOverVolt	Yes	Battery over-voltage protection
07	BusOverVoltHw	Yes	Busbar over-voltage hardware protection
08	BusOverVoltSw	Yes	Busbar over-voltage software protection
09	PvVoltHigh	Yes	PV input over-voltage protection
10	PvBoostOCSw	NO	Boost circuit over-current software protection
11	PvBoostOCHw	NO	Boost circuit over-current hardware protection
12	SpiCommErr	Yes	Master-slave chip SPI communication failure
13	OverloadBypass	Yes	Bypass overload protection
14	OverloadInverter	Yes	Inverter overload protection
15	AcOverCurrHw	Yes	Inverter over-current hardware protection
16	AuxDspReqOffPWM	Yes	Slave chip request switch off failure
17	InvShort	Yes	Inverter short-circuit protection
18	Bussoftfailed	Yes	Busbar soft start failure
19	OverTemperMppt	NO	MPPT heat sink over-temperature protection
20	OverTemperInv	Yes	Inverter heat sink over-temperature protection
21	FanFail	Yes	Fan failure
22	EEPROM	Yes	Reservoir failure

Fault Code	Meaning	Does it Affect the outputs	Instructions
23	ModelNumErr	Yes	Wrong model
24	Busdiff	Yes	Busbar voltage imbalance
25	BusShort	Yes	Busbar short circuit
26	Rlyshort	Yes	Inverter output back flow to bypass
28	LinePhaseErr	Yes	Utility input phase fault
29	BusVoltLow	Yes	Busbar under-voltage protection
30	BatCapacityLow1	Yes	Battery SOC below 10% alarm (Only enable BMS take effect)
31	BatCapacityLow2	NO	Battery SOC below 5% alarm (Only enable BMS take effect)
32	BatCapacityLowStop	Yes	Battery dead (Only enable BMS take effect)
58	BMSComErr	NO	BMS communication failure
60	BMSUnderTem	NO	BMS under-temperature alarm (Only enable BMS take effect)
61	BMSOverTem	NO	BMS over-temperature alarm (Only enable BMS take effect)
62	BMSOverCur	NO	BMS over-current alarm (Only enable BMS take effect)
63	BMSUnderVolt	NO	BMS under-voltage alarm (Only enable BMS take effect)

7.2、Troubleshooting

Fault Code	Meaning	Causality	Remedy
/	Screen no display	No power input, or in sleep mode.	Closing the circuit breaker. Ensure the rocker switch is ON. Push any button on the panel to exit sleep mode.
01	Battery under-voltage	The battery voltage is lower than the value set in parameter [14].	Charge the battery and wait until the battery voltage is higher than the value set in the parameter item [14].
03	Battery not connected	The battery is not connected, or the BMS in discharge protection	Check whether the battery is reliably connected; check whether the circuit breaker of the battery is not closed; ensure that the BMS of the Li-ion battery can communicate properly.

Fault Code	Meaning	Causality	Remedy
04	Battery over-discharge	The battery voltage is lower than the value set in the parameter [12].	Manual reset: Power off and restart. Automatic reset: charge the battery so that the battery voltage is higher than the value set in the parameter item [35].
06	Battery over-voltage when charging	Battery is in over-voltage condition.	Manually power off and restart. Check to see if the battery voltage exceeds the limit. If it exceeds, the battery needs to be discharged until the voltage is below the battery's over-voltage recovery point.
13	Bypass over-load (software detection)	Bypass output power or output current overload for a certain period of time.	Reduce the load power and restart the device. Please refer to item 11 of the protection features for more details.
14	Inverter overload (software detection)	Inverter output power or output current overload for a certain period of time.	
19	Heat sink of PV input over-temperature (software detection)	Heat sink of PV input temperature exceeds 90°C for 3s.	Resume normal charge and discharge when the temperature of the heat sink has cooled to below the over-temperature recovery temperature
20	Heat sink of inversion over-temperature (software detection)	Heat sink of inversion temperature exceeds 90°C for 3s.	
21	Fan failure	Fan failure detects by hardware for 3s.	Manually toggle the fan after switching off to check for blockage by foreign objects.
26	AC Input relay shortcircuit	Relay for AC input sticking	Manually power off and restart; if the fault reappears after restarting, You need to contact the after-sales service to repair the machine.
28	Utility input phase fault	AC input phase does not coincide with AC output phase	Ensure that the phase of the AC input is the same as the phase of the AC output, e.g. if the output is in split-phase mode, the input must also be in split-phase.

**NOTICE**

If you encounter a fault with the product that cannot be solved by the methods in the table above, please contact our after-sales service for technical support and do not disassemble the equipment yourself.

8. Protection and Maintenance

8.1. Protection features

No	Protection Feature	Instruction
1	PV input current/power limiting protection	When the charging current or power of the PV array configured exceeds the PV input rated value, the inverter will limit the input power and charge at the rated.
2	PV input over-voltage	If the PV voltage exceeds the maximum value allowed by the hardware, the machine will report a fault and stop the PV boost to output a sinusoidal AC wave.
3	PV night reverse current protection	At night, the battery is prevented from discharging through the PV module because the battery voltage is greater than the voltage of PV module.
4	AC input over-voltage protection	When the AC input voltage of each phase exceeds 140V, the mains charging will be stopped and switched to the inverter mode.
5	AC input under-voltage protection	When the AC input voltage of each phase below 90V, the utility charging will be stopped and switched to the inverter mode.
6	Battery over-voltage protection	When the battery voltage reaches the over-voltage cut-off point, the PV and the utility will automatically stop charging to prevent the battery from being overcharged and damaged.
7	Battery under-voltage protection	When the battery voltage reaches the under-voltage cut-off point, the inverter will automatically stop the battery discharge to prevent damage from over-discharging the battery.
8	Battery over-current protection	After a period when the battery current exceeds that allowed by the hardware, the machine will switch off the output and stop discharging the battery.
9	AC output short-circuit protection	When a short-circuit fault occurs at the load output terminal, the AC output is immediately turned off and turned on after 1 second. If the output load terminal is still short-circuited after 3 attempts, the inverter must be manually restarted after first removing the short-circuit fault from the load before the normal output can be restored.
10	Heat sink over-temperature protection	When the internal temperature of the inverter is too high, the inverter will stop charging and discharging; when the temperature returns to normal, the inverter will resume charging and discharging.
11	Inverter over-load protection	After triggering the overload protection the inverter will resume output after 3 minutes, 5 consecutive overloads will switch off

		the output until the inverter is restarted. (102% < load < 110%) $\pm 10\%$: error and output shutdown after 5min; (110% < load < 125%) $\pm 10\%$: error and output shutdown after 10s. Load > 125% $\pm 10\%$: error reported and output switched off after 5s.
12	AC output reverse	Prevents AC back flow from the battery inverter to the bypass AC input.
13	Bypass over-current protection	Built-in AC input over-current protection circuit breaker.
14	Bypass phase inconsistency protection	When the phase of the bypass input and the phase of the inverter split do not match, the inverter disables switching to the bypass output to prevent the load from dropping out or short-circuiting when switching to the bypass.

8.2、 Maintenance

To maintain optimum and long-lasting working performance, we recommend that the following items are checked twice a year.

1. Ensure that the airflow around the inverter is not blocked and remove any dirt or debris from the radiator.
2. Check that all exposed conductors are not damaged by sunlight, friction with other surrounding objects, dry rot, insect or rodent damage, etc. The conductors need to be repaired or replaced if necessary.
3. Verify that the indications and displays are consistent with the operation of the equipment, note any faults or incorrect displays and take corrective action if necessary.
4. Check all terminals for signs of corrosion, insulation damage, high temperatures or burning/discolouration and tighten terminal screws.
5. Check for dirt, nesting insects and corrosion, clean as required, Clean the insect screen regularly.
6. If the lightning arrester has failed, replace the failed arrester in time to prevent lightning damage to the inverter or other equipment of the user.

DANGER

- Make sure that the inverter is disconnected from all power sources and that the capacitors are fully discharged before carrying out any checks or operations to avoid the risk of electric shock.

The Company shall not be liable for damage caused by :

1. Damage caused by improper use or use in a wrong location.
2. Photovoltaic modules with an open circuit voltage exceeding the maximum permissible voltage.
3. Damage caused by the operating temperature exceeding the restricted operating temperature range
4. Dismantling and repair of the inverter by unauthorised persons.
5. Damage caused by force majeure: damage during transport or handling of the inverter.

9. Datasheet

MODEL	SPH8K48SP	SPH10K48SP	CAN BE SET
INVERTER OUTPUT			
Rated Output Power	8,000W	10,000W	
Max.Peak Power	16,000W	20,000W	
Rated Output Voltage	120/240Vac (split phase/single phase)		Y
Load Capacity of Motors	5HP	6HP	
Rated AC Frequency	50/60Hz		Y
Waveform	Pure Sine Wave		
Switch Time	10ms (typical)		
Parallel capacity	/		
Overload	<p>After triggering the overload protection the inverter will resume output after 3 minutes, 5 consecutive overloads will switch off the output until the inverter is restarted.</p> <p>(102%<load<110%) ±10%: error and output shutdown after 5min;</p> <p>(110% < load < 125%) ±10%: error and output shutdown after 10s. Load > 125% ±10%: error reported and output switched off after 5s.</p>		
BATTERY			
Battery Type	Li-ion / Lead-Acid / User Defined		Y
Rated Battery Voltage	48Vdc		
Voltage Range	40-60Vdc		Y
Max.MPPT Charging Current	200A		Y
Max.Mains/Generator Charging Current	100A	120A	Y
Max.Hybrid Charging Current	180A	200A	Y
PV INPUT			
Num. of MPP Trackers	2		
Max.PV array power	11,000W		
Max.input current	22/22A		
Max.Voltage of Open Circuit	500Vdc		
MPPT Voltage Range	125-425Vdc		
MAINS / GENERATOR INPUT			
Input Voltage Range	90-140Vac		
Frequency Range	50/60Hz		
Bypass Overload Current	63A		
EFFICIENCY			
MPPT Tracking Efficiency	99.9%		
Max. Battery Inverter Efficiency	92%		

GENERAL		
Dimensions	620*445*130mm (2*1.5*0.4ft)	
Weight	24.5kg (59lb)	
Protection Degree	IP20, Indoor Only	
Operating Temperature Range	-10~55°C, >45°C derated (14~131°F, >113°F derated)	
Noise	<60dB	
Cooling Method	Internal Fan	
Warranty	1 Years	
COMMUNICATION		
Embedded Interfaces	RS485 / CAN / USB / Dry contact	Y
External Modules (Optional)	Wi-Fi / GPRS	Y
CERTIFICATION		
Safety	IEC62109-1, IEC62109-2, UL1741	
EMC	EN61000-6-1, EN61000-6-3, FCC 15 class B	
RoHS	Yes	

PowerMax 314 Outdoor Series

Energy Storage Battery User Manual

V3.0



1. Instructions

Thank you very much for choosing the PowerMax 314 Outdoor series household energy storage system developed and produced by our company. Please read and understand all contents of the Manual carefully

before installing and using the product. If you have any suggestions during the use, please do not hesitate to give us feedback.

The product must be used in compliance with all local standards, laws, and regulations. Any non-compliant use may lead to personal injury and property loss.

The drawings provided in this Manual are used to explain the concepts related to the product, including product information, installation guide, electrical connection, system debugging, safety information, common problems and maintenance, etc.

The internal parameters of this product have been adjusted before delivery. No internal parameters can be changed without permission. Any unauthorized changes to the settings will invalidate the warranty, and the Company will not be liable for any loss resulting therefrom.

This Manual and other related documents are an integral part of the product and should be kept properly for onsite installation personnel and related technical personnel to consult.

In order to continuously improve customer satisfaction, both this product and the Manual are continuously being improved and upgraded. If there is a discrepancy between the received manual and the product, it may be due to a product version upgrade. Please refer to the actual product.

The Manual will be continuously updated and revised, but it is inevitable that there may be slight discrepancies or errors with the actual product. Please refer to the actual product purchased by the user. The pictures mentioned in this document are for reference only and the actual product shall prevail.





1.1 Meaning of Abbreviations

AC	Alternating Current
DC	Direct Current
PV	Photovoltaic
BMS	Battery Management System
PCS	Power Conversion System
RJ45	Registered Jack 45
SOC	State Of Charge
C	Charge C-rate
RS485	RS485 Communication Interface
CAN	Controller Area Network

1.2 Symbol Stipulations

There may be following symbols herein, and their meanings are as follows.











Symbols	Description
---------	-------------



	<i>Indicate a hazard with a high level of risk which, if not avoided, will result in death or serious injury.</i>
	<i>Indicate a hazard with a medium level of risk which, if not avoided, could result in death or serious injury.</i>
	<i>Indicate a hazard with a low level of risk which, if not avoided, could result in minor or moderate injury.</i>
	<i>Warning information about device or environment safety. If not avoided, equipment damage, data loss, performance degradation or other unanticipated results may be resulted in. The "NOTICE" does not involve any personal injury.</i>

2 Safety Precautions

2.1 Safety Symbols

This product contains the following symbols, please pay attention to identifying.

Symbols	Description
	<i>Observe enclosed documentation</i>
	<i>Danger. Risk of electric shock!</i>
	<i>Danger of high voltages. Danger to life due to high voltages in the Energy storage system</i>
	<i>Hot surface</i>
	<i>CE certification</i>
	<i>Do not touch the product in 5mins after shutdown</i>
	<i>Comply with RoHS standard</i>
	<i>The Energy storage system should not be disposed together with the household waste.</i>
	<i>Flammability risk</i>
	<i>Electric shock hazard</i>
	<i>Keep the battery away from open flame or ignition sources</i>

	<p>Keep the battery away from electric sparks</p>
	<p>Recycling</p>
	<p>Rainproof and moisture-proof</p>

2.2 General Safety



2.2.1 Important Notice







Before installing, operating, and maintaining the device, please read this Manual first and follow the symbols on the device and all the safety precautions in this Manual.

The "DANGER", "CAUTION", "ATTENTION", and "NOTICE" indicators in this manual are not exhaustive of all safety considerations but serve as supplements to all safety precautions. The Company will not be liable for any violation of general safety operating requirements, or any violation of safety standards for the design, production, and use of the device. The device must be used in an environment that meets the requirements of the design specifications. Otherwise, the device may fail, and the abnormal device function or component damage, personal safety accident, and property loss arising from this are not covered within the quality assurance scope of the device. When installing, operating, and maintaining the device, the local laws, regulations, and codes shall be followed. The safety precautions in this Manual are only supplements to local laws, regulations, and codes. The Company shall not be liable for any of the following circumstances.

- The device is not run under the conditions of operating described in this Manual.
- The installation and operating environment is beyond the requirements of relevant international or national standards.
- The product is disassembled or changed, or the software code is modified without authorization.
- The operation instructions and safety warnings related with the product and in the documents are not followed.
- Damage of the device is caused by abnormal natural environment (force majeure, such as earthquake, fire, and storm).
- Transportation damage is caused during customer's own transportation.
- The storage condition does not meet the requirements of the product related documents and causes damage.

2.2.2 General Requirements

	<p>Operating while powered on during installation is strictly prohibited.</p>
	<p>It is strictly prohibited to install, use, and operate any outdoor equipment or cables (including but</p>

	<i>not limited to transporting equipment, operating equipment and cables, plugging and removing signal ports connected to the outdoor, working at altitude, and outdoor installation) in severe weather, such as thunder, rain, snow, and gale level 6.</i>
	<i>In case of any fire, evacuate the building or equipment area and press the fire alarm bell or dial the fire call. Under any circumstances, re-entry into a burning building is strictly prohibited.</i>
	<i>Under no circumstances should the structure and installation sequence of the device be changed without the manufacturer's permission.</i>
	<i>The battery terminal components shall not be affected during transportation. And, the battery terminal bolts shall not be lifted or transported.</i>
	<i>It is strictly prohibited to alter, damage or block the marks and nameplates on the device.</i>
	<i>The composition and working principle of the entire photovoltaic power generation system, as well as the relevant standards of the country/region where the project is located shall be known fully.</i>
	<i>After the device is installed, the empty packing materials, such as cartons, foam, plastics, and cable ties, shall be removed from the device area.</i>

2.2.3 Personnel Safety

- *When operating the device, appropriate personal protective equipment shall be worn. If any fault that may lead to personal injury or damage of the device is found, immediately terminate the operation, report to the responsible person, and take effective protective measures.*
- *Before using any tools, learn the correct method of using the tool to avoid injuries and damage of the device.*
- *When the device is running, the temperature of the case is high, which may cause burns. Therefore, do not touch the case.*
- *In order to ensure personal safety and normal use, reliable grounding should be carried out before use.*
- *Do not open or damage the battery. The electrolyte released is harmful to skin and eyes, so avoid touching it.*
- *Do not place irrelevant items on the top of the device or insert them into any part of the device.*
- *Do not place flammable items around the device.*
- *Never place the battery in the fire to avoid explosion and prevent the personal safety from being endangered.*
- *Do not place the battery module in water or other liquids.*
- *Do not short-circuit the battery terminals, because short-circuiting of the battery may cause combustion.*
- *The battery may pose electric shocks and large short-circuit currents. When using the battery, the following precautions should be paid attention to:*
 - a) *The metal objects, such as watch and rings, shall be removed.*

- b) *Tools with insulated handles should be used.*
 - c) *Rubber gloves and shoes should be worn.*
 - d) *The charging power supply shall be disconnected before connecting or disconnecting terminals of the battery.*
 - e) *Check whether the battery is accidentally grounded. If the battery is accidentally grounded, remove the power supply from the ground.*
- *Do not clean the internal and external electrical components of the cabinet with water or detergent.*
 - *Do not stand, lean or sit on the device.*
 - *Do not damage any modules of the device.*

2.3 Personnel Requirements

- *The personnel in charge of installation and maintenance must be strictly trained to understand all safety precautions and master proper operation methods.*
- *Only qualified professionals or trained personnel are allowed to install, operate and maintain the device.*
- *The personnel who operate the device, including the operators, trained personnel and professionals, must have special operation qualifications required by the local country, such as high voltage operation, working high above the ground, and special equipment operation qualification.*
- *The replacement of device or components (including software) must be carried out by professionals or authorized personnel.*

2.4 Electrical Safety

2.4.1 General Requirements



Before making electrical connections, ensure that the device is not damaged; otherwise, electric shock or fire may occur.



Never install or remove any power cables when the power is on. The electric arcs or sparks may be generated at the moment when the power cable contacts with the conductor, which may cause fire or personal injuries.

- *All the electrical connections must meet the electrical standards of the country/region where the project is located.*
- *The cables prepared by users themselves shall comply with local laws and regulations.*
- *Special insulating tools should be used in high-voltage operations.*
- *Before connecting the power cord, ensure that the label identification on the power cord is correct.*
- *Operations on the device are allowed only five minutes after the device is completely powered off.*
- *The insulation layer of the cable may be aged or damaged when the cable is used in a high temperature environment. Therefore, the distance between the cable and the heat source must be at least 30mm.*

- Cables of the same type should be bundled together. Whereas the cables of different types should be routed at least 30mm apart, and shall not be wrapped together or crossed.

2.4.2 Grounding Requirements

- When installing the device to be grounded, the protective grounding wire must be installed first; when removing the device, the protective grounding wire must be removed at last.
- It is forbidden to destroy the grounding conductor.
- It is forbidden to operate the device without a grounding conductor installed.
- The device shall be permanently connected to the protective grounding wire. Before operating the device, electrical connection of the device shall be checked to ensure that the device is reliably grounded.

2.5 Installation Environment Requirements

- Do not install or use this product in an environment where the temperature is lower than -10 °C or higher than 50 °C.
- It should be installed in a dry and well-ventilated environment to ensure good heat dissipation performance.
- The product can be installed at a maximum altitude of 2,000m(6561ft).
- The installation position should be away from the fire source.
- The product should be installed and used away from children and animals.
- The installation position should be far away from water sources, such as faucets, sewer pipes, and sprinklers, to avoid entering of water.
- The device should be placed on a firm and flat supporting surface.
- Do not place any inflammable or explosive items around the device.
- When the device is running, do not block the ventilation vent or heat dissipation system to prevent fire caused by high temperature.



The operation and service life of the energy storage is related to the operating temperature. The energy storage should be installed at a temperature equal to or better than the ambient temperature.



Max+50°C



Min-10°C



RH.+5%~+95%

3 Product Introduction

3.1 Battery Specifications

Product model	PowerMax 314 Outdoor
Rated voltage	51.2V
Voltage Range	44.8~57.6Vdc

Rated capacity	314Ah
Rated energy	16.07kWh
Nameplate Energy Capacity	16.07kWh
Usable Energy	15.42kWh
Max.Depth of discharge	> 96%
Rated DC power	7.68kW
Maximum continuous Discharge Rate	7.68kW
Weight	123kg (271lb)
Dimensions (L*W*H)	1048*460*271mm (41.26*18.11*10.67inch)
Standard charge / discharge current	150A/150A
Max. Charging / discharging current	190A/190A
Peak charging current	220A (3S)
Peak discharging current	220A (3S)
Breaker Current	240A
Screen	Touch Screen
Battery type	LFP
Life cycle (80% DOD,0.5C,25℃)	8000 Cycles
Max. charging voltage	57.6V
Over discharge voltage	44.8V
Max. number of parallel	16
Communication interfaces	CAN/RS485/USB/WIFI/Bluetooth
Lithium Battery Standard	UN38.3, MSDS, EN55032, EN55024, EN61000-3-2, EN61000-3-3, UL1973,UL9540A
Storage time / temperature	6 months @25℃ (77°F) ;3 months @35℃ (95°F) ;1 months @45℃ (113°F) ;
Charging temperature range	0~55℃ (32~131°F)
Discharging temperature range	-10~55℃ (14~131°F)
Cooling method	Natural cooling
Enclosure protection rating	IP65
Operation Environment	Indoor & Outdoor

3.2 Appearance Description

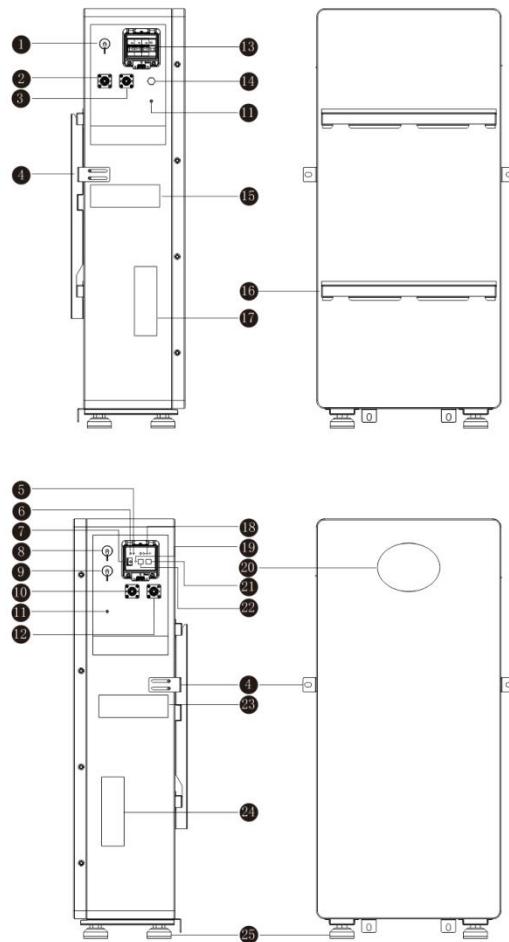

1, RS485 (Connect other battery)	2, Battery Negative	3, Battery Positive	4, Fixed accessories
5, LED(ALM)	6, LED(RUM)	7, Turn On/Off	8, RS485/CAN (Connect inverter)
9, RS485 (Connect other battery)	10, Battery Positive	11, Grounding screw	12, Battery Negative
13, Breaker	14, vent valve	15, Handle (15) plus (23) are used simultaneously	16, Mounting Frame
17, Handle (17) plus (24) are used simultaneously	18, SOC (State of Capacity)	19, Reset	20, LCD Touch Screen
21, USB (Connect PC)	22, Address	23, Handle(15) plus (23) are used simultaneously	24, (17) plus (24) are used simultaneously
25, Foot cup			

Communication interface definition

Number	Communication	Interface Type	Picture	instruction
--------	---------------	----------------	---------	-------------

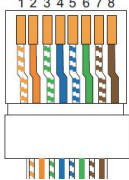
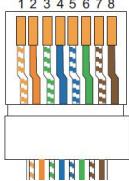
<p>①⑬</p>	<p>RS485 (Connect other battery)</p>	<p>RJ45</p>		<p>1-RS485-B 2-RS485-A 7-RS485-A 8-RS485-B</p>
<p>⑩</p>	<p>RS485/CAN (Connect inverter)</p>	<p>RJ45</p>		<p>1-RS485-B 2-RS485-A 3-GND 4-CAN-H 5-CAN-L 6-GND 7-RS485-A 8-RS485-B</p>

4 Application Scenarios

The lithium iron phosphate batteries with high performance and long service life are used in the energy storage module. Meanwhile, the modular structure design is adopted. Each energy storage module is internally integrated with the intelligent BMS system, which can be easily expanded and can be combined into 60Kwh battery pack at most.

The battery storage can be combined with inverter to form an off-grid photovoltaic system, which can solve the problem of electricity consumption in areas without electricity.

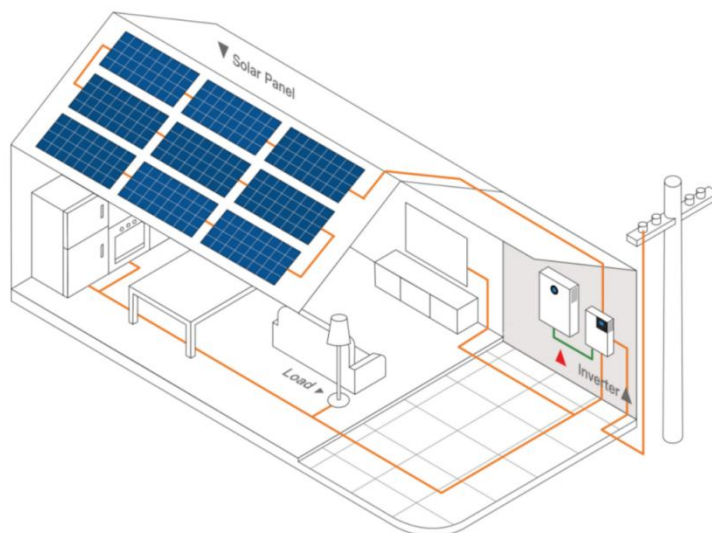

5 System Installation











5.1 Inspections before Installation

Inspection of outer package

Before opening outer package of the energy storage, check if there is any visible damage on the outer package, such as holes, cracks or other signs of possible internal damage, and check the type of energy storage. If there is any abnormality on the package or model of the energy storage is inconsistent, do not open it and contact us as soon as possible.



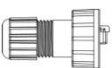





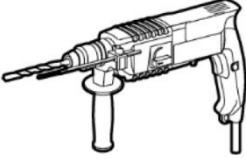

Inspection of deliverables

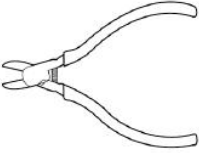
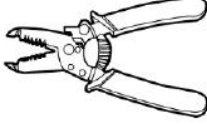
After opening outer package of the energy storage, check if the deliverable is complete and whether there is any visible external damage. If any items are missing or damaged, please contact us.

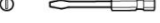
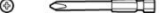
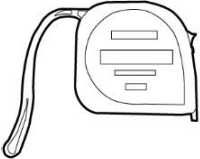
NO.	Picture	Item	Quantity	Specification
1		Battery Pack	1	16.07kWh
2		Mounting Frame	3	580*85.8*30mm
3		Mounting Frame Connecting Strip	1	375*39*12mm
4		Screw	6	M4*10
5		Mounting Frame Screw	12	M8*60 expansion bolt
6		Side fastener	2	80*40*36mm
7		Screw	4	M5*12
8		Power Cable	2	1.5m
9		Signal cable	1	RJ45, 1.5m
10		RJ45 waterproof connector	1	M25*37mm
11		Installation auxiliary board	1	500*500mm
12		Grounding Wrie	1	1.5m

5.2 Preparation of Tools and Meters

Types	Tools and meters
-------	------------------

<i>Installation tool</i>			
			  
			
<i>Personal protective equipment</i>			
			

5.3 Selection of Installation Location

5.3.1 Basic Requirements

- *When the energy storage is running, the temperature of the case and the radiator will be high. Therefore, do not install them in a place that is easy to touch.*

- *Do not install in areas where flammable and explosive materials are stored.*

- *If the energy storage is installed in areas with salt damage, it will be corroded and may cause fire.*

Therefore, do not install it outdoors in areas with salt damage. The areas with salt damage are defined as the areas which are not 500m away from shore or will be affected by sea breezes. The areas affected by the sea breezes vary depending on meteorological conditions (e.g. typhoons, monsoons) or topographical conditions (dams, hills).

- *Do not install in the place where children can touch.*

- *The energy storage cannot be installed forwardly, horizontally, inversely, backwardly or sideways.*

- *When drilling holes on walls or ground, the goggles and protective gloves shall be worn.*

- *During drilling, the device should be shielded to prevent debris from falling into the device. After drilling, the debris shall be cleaned up in time.*

- *When handling any heavy objects, you should be prepared to bear loads to avoid being crushed or sprained.*

- *When handling the device by hand, wear protective gloves to avoid injury.*

5.3.2 Installation Space Requirements

Floor Mount: The battery should be placed in the right position first, and the installation site should be smooth, and the wall should be solid, and the distance between the batteries should be greater than 200-350mm.

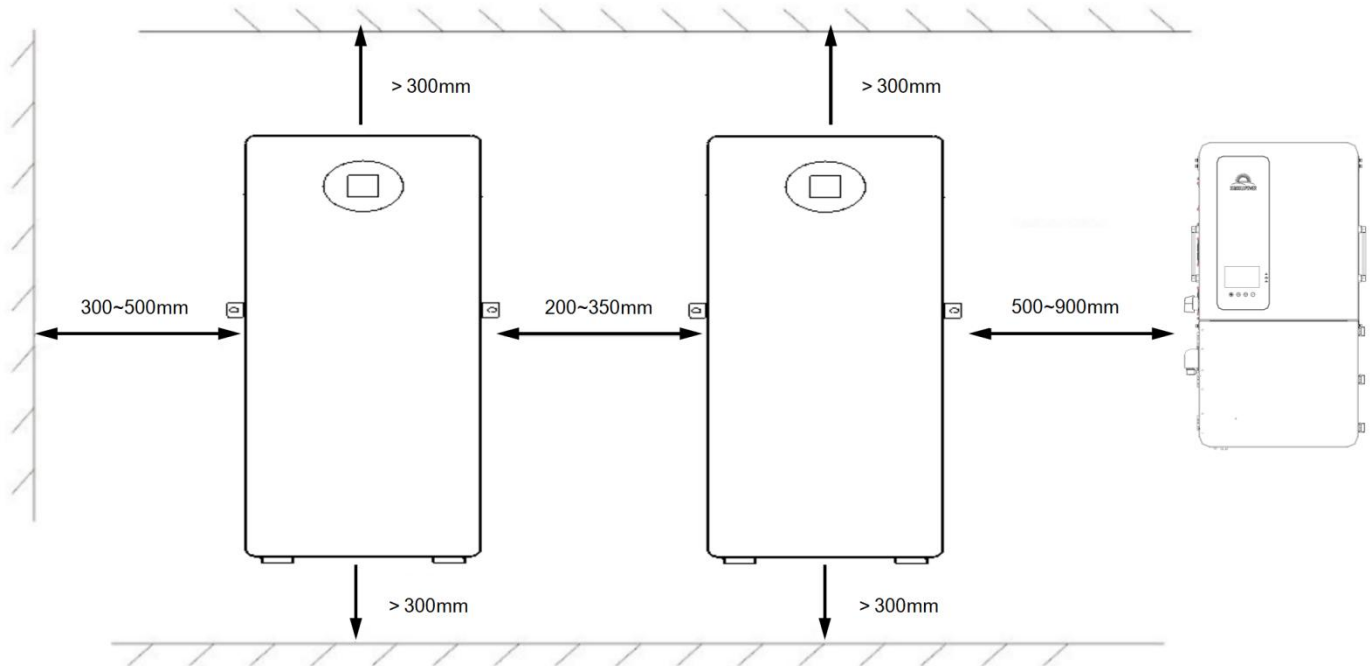

Wall mount: The battery should be placed in the right position first, and the installation site should be smooth, and the wall should be solid, and the device is 200mm away from the ground, the distance between the batteries should be greater than 200-350mm.

5.4 Device Installation

5.4.1 Wall mount

5.4.1.1 Installation Location Selection

Determine the installation position, put the installation auxiliary board in the proper position, and mark the place where the holes need to be punched.

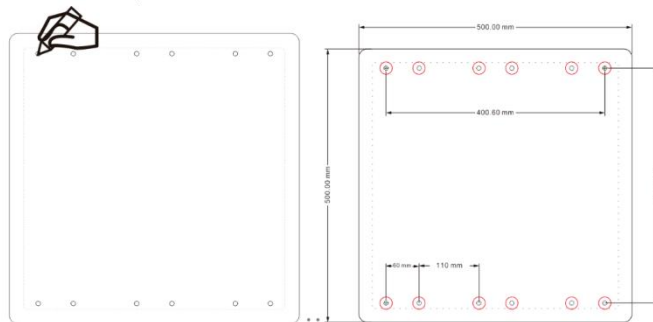

5.4.1.2 Install Expansion Bolts



To avoid electrical shock or other injury, inspect existing electronic or plumbing installations before drilling holes.



Choose suitable firm wall with thickness greater than 80mm.

Drill 12 holes according to the hole position, it is $\phi 10$ with depth of 45~50mm. Hammer the M8 screws to the above holes, and screw the nut.

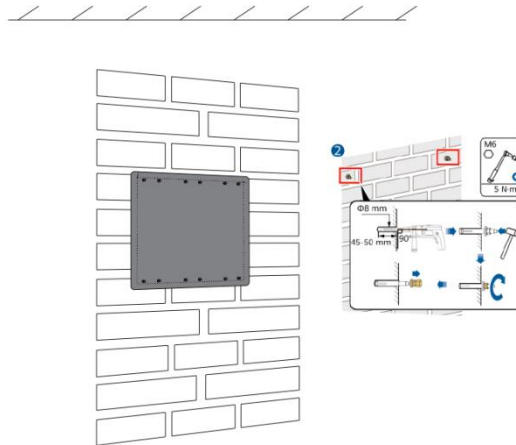

5.4.1.3 Install Bracket Screws

Secure the mounting bracket with 6 screws.

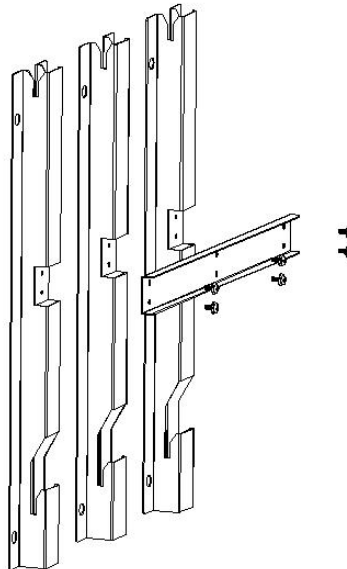

5.4.1.4 Fix Mounting Frame

Make the convex side outward and fix the mounting frame to the 12 screws.

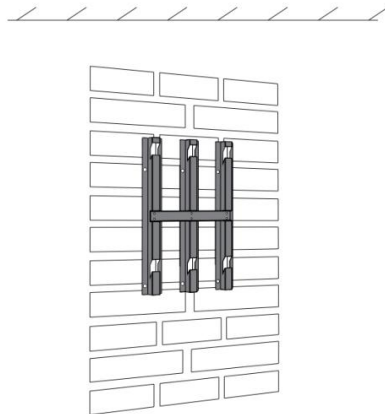

5.4.1.5 Install Battery Pack



The battery pack is very heavy, which requires multiple people to install.

Keep the battery balanced, and then slowly hang the battery on the frame through the match hooks.

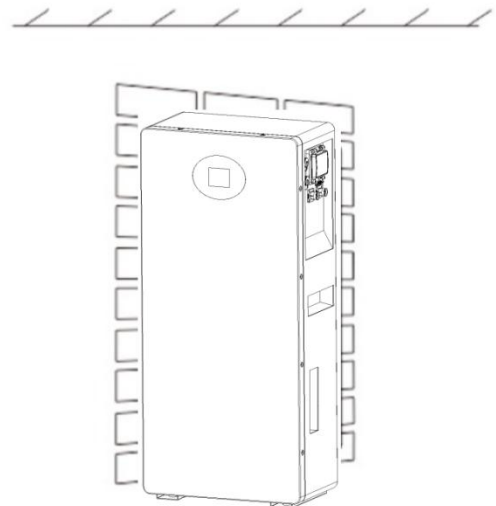
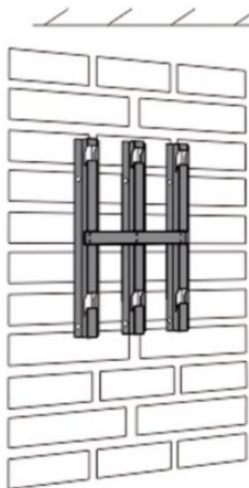

5.4.2 Floor Mount

5.4.2.1 Install Expansion Bolts



To avoid electrical shock or other injury, inspect existing electronic or plumbing installations before drilling holes.

Drill 2 holes according to the hole position, it is $\phi 10$ with depth of 45~50mm. Hammer the M8 screws to the above holes, and screw the nut.

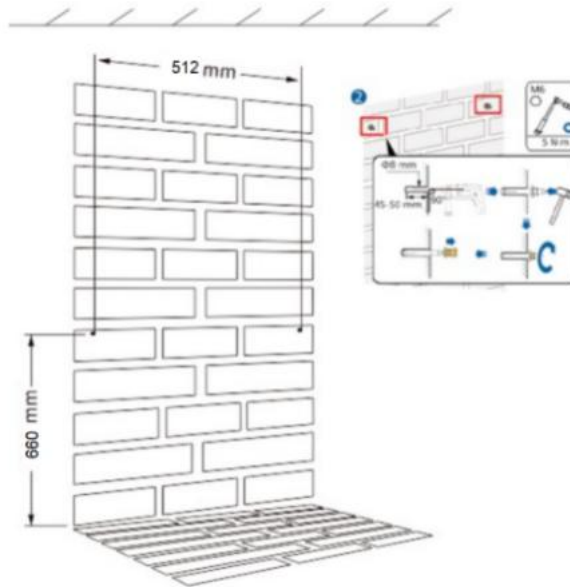

5.4.2.2 Install Battery Pack

Place the battery on a flat, firm floor and install the fixing accessories.

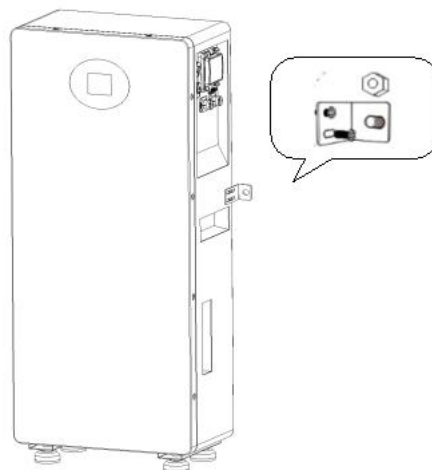

6 Electrical Connection



Before electrical connection, please ensure that the switches of the energy storage are in the "OFF" state. Otherwise, the high voltage of the device may cause electric shock.



The operations related to electrical connections must be carried out by professional electrical technicians. When carrying out electrical connections, the operator must wear personal protective articles.

6.1 Preparation of Cables

No.	Cables	Description	Recommended specifications	Source
1	Power Cable	Power cable between the storage battery and inverter		Provide with the product together
2	Signal line	Signal cable between battery modules or between battery and inverter		Provide with the product together
3	Ground wire	Ground cable between the storage battery modules		Provide with the product together
4	Photovoltaic input line	Cable between the photovoltaic panel and power module	Cable diameter 6mm ² /10AWG	Prepare by the user

6.2 Electrical Connection of One Battery Module

6.2.1 Connecting Grounding Wire

Each energy storage battery module shall relate to the grounding wire provided with the product together.

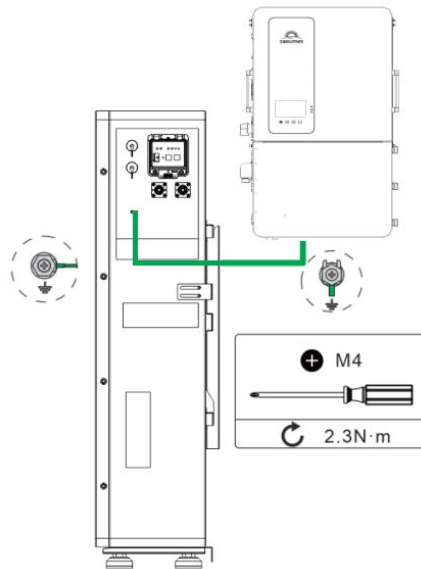

6.2.2 Connecting Power Cord

When connecting the battery wiring, please make sure that the battery switch is off and the indicator light is off. If the plug is connected properly, you will hear a "click" sound.

If you need to unplug the plug, you need to first turn off all devices and battery switches, and then wait for 5 minutes before proceeding, then press the self-locking clasp and unplug.

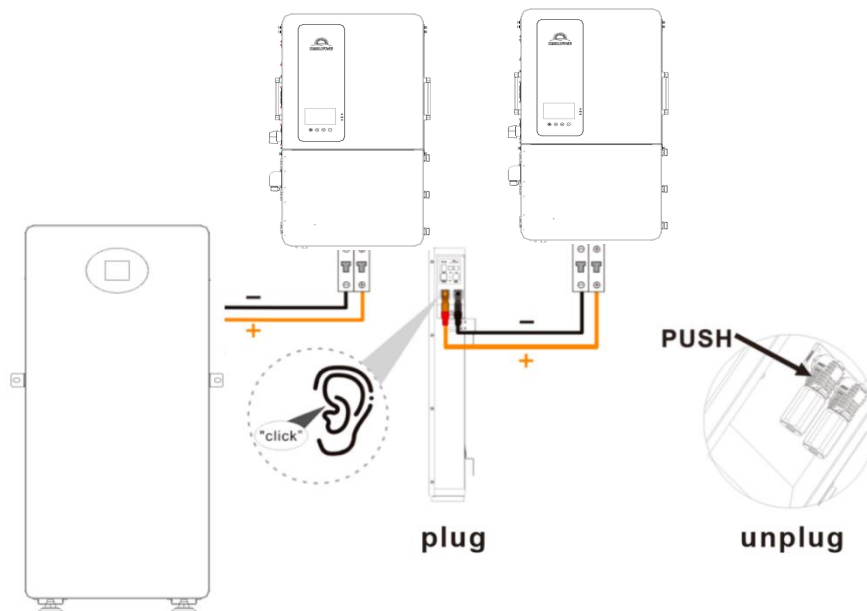

6.2.3 Connecting Signal Line

The signal line shall be used to connect RS485-Inverter interface for battery module and inverter.

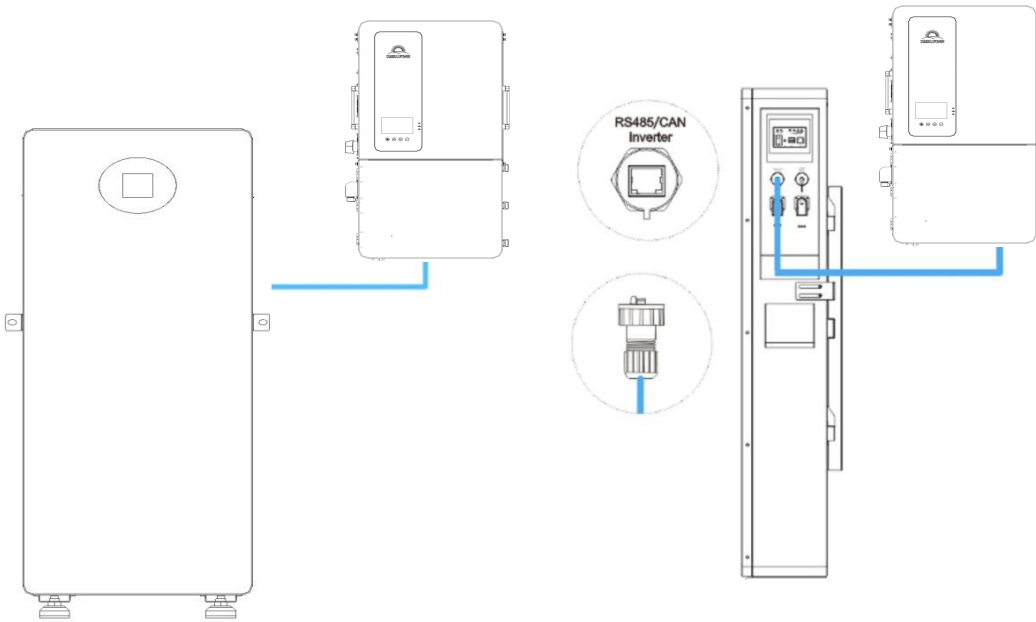

When connecting the inverter, the communication line must be connected, and the communication protocol must be consistent.



If you use a standard network cable, please cut off pins 1 and 2 for connection.

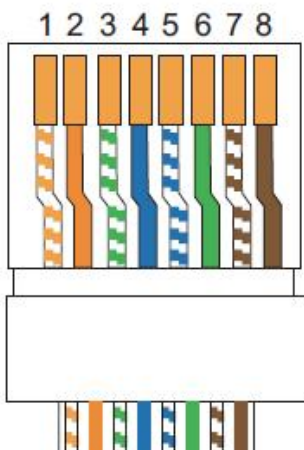

If you use a standard network cable to connect the inverter

PIN1	White-orange	RS485-B
PIN2	Orange	RS485-A
PIN3	White-green	
PIN4	Blue	CAN-H
PIN5	White-blue	CAN-L
PIN6	Green	
PIN7	White-brown	RS485-A
PIN8	Brown	RS485-B

6.2.4 Energy Storage Battery Module Address Setting

When using a single battery, please set the address to 0.

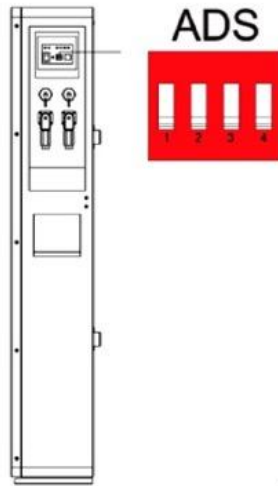

6.3 Electrical Connection of Multiple Battery Modules

6.3.1 Connecting Grounding Wire

Each energy storage battery module shall be connected with the grounding wire provided with the product together. If there are multiple batteries, you need to connect the ground wire of each battery.

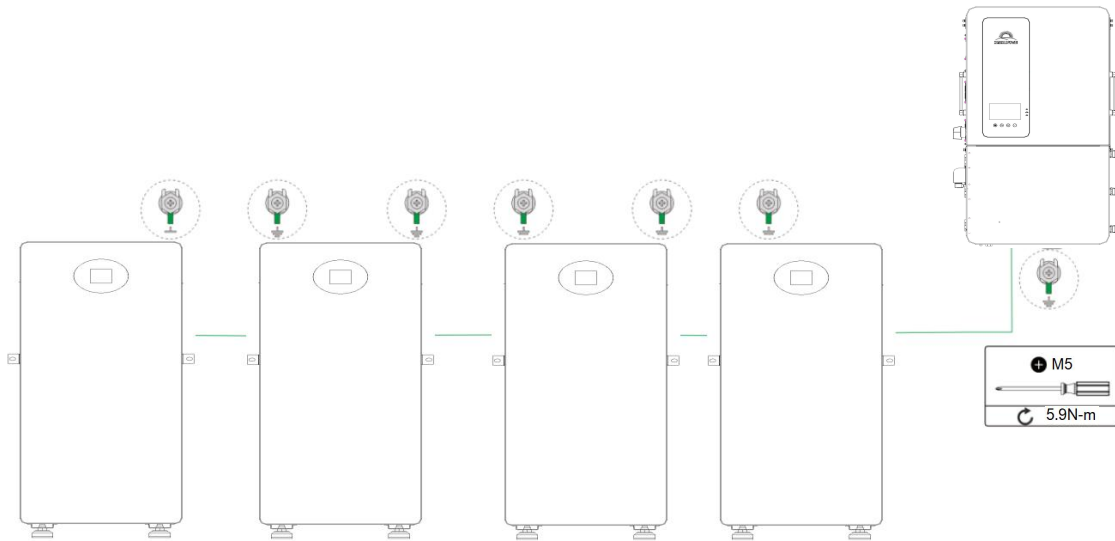

6.3.2 Connecting Power Cord

If there are 2 batteries used in parallel, you need to connect the power cord of each battery.

Parallel connection cable of battery modules are optional products. If necessary, please contact your local dealer.



If the current of the inverter exceeds the rated current of the battery, a busbar must be used and parallel connection cable cannot be used. Parallel connection cable can only expand capacity, not power.



Batteries can only be connected in parallel and cannot be used in series

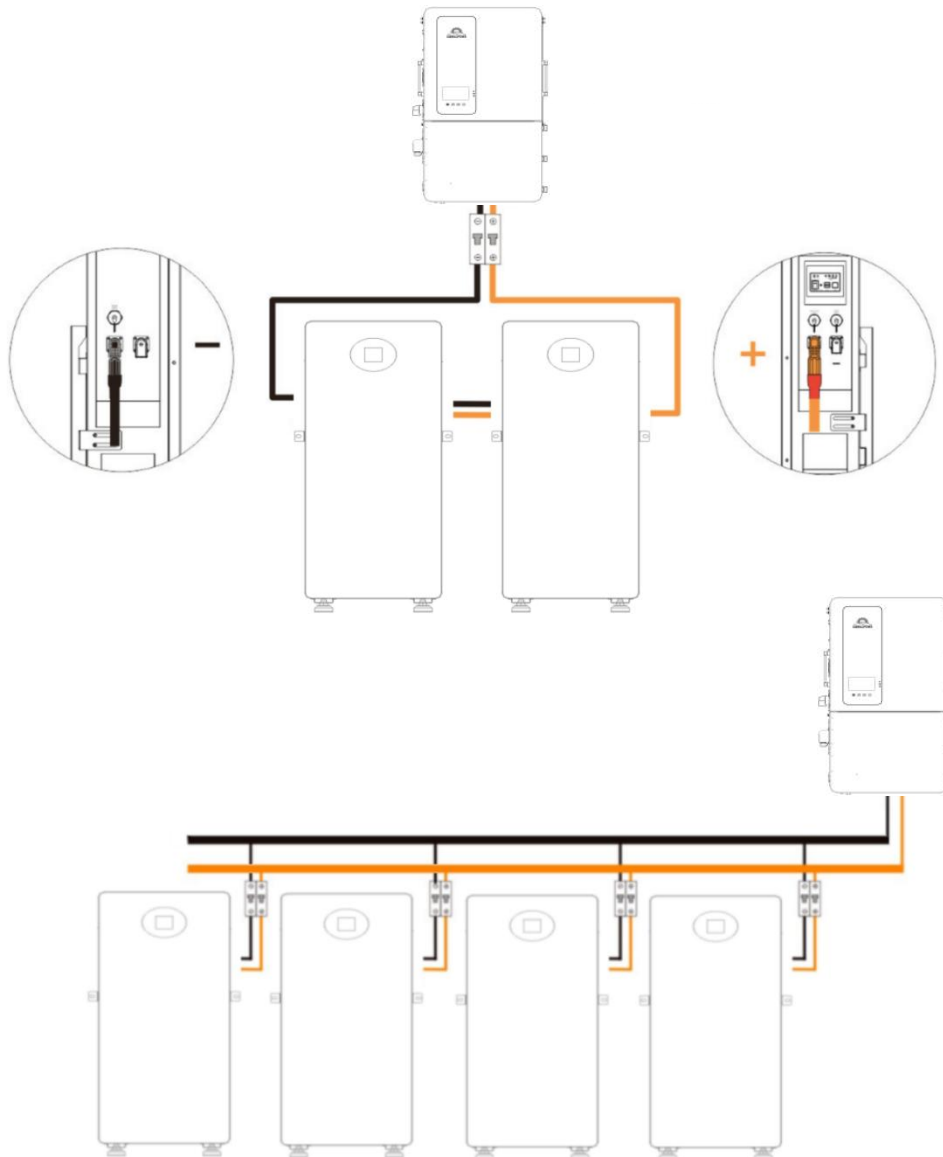

If multiple batteries are used in parallel, Bus bar is required.

6.3.3 Connecting Signal Line



If there are multiple batteries connected in parallel, the slave switch must be turned on first, and then the master switch should be turned on last.

If there are multiple batteries, you need to connect the communication line of each battery. Battery and battery connection use RS485-Battery interface, battery and inverter connection need RS485-Inverter interface.

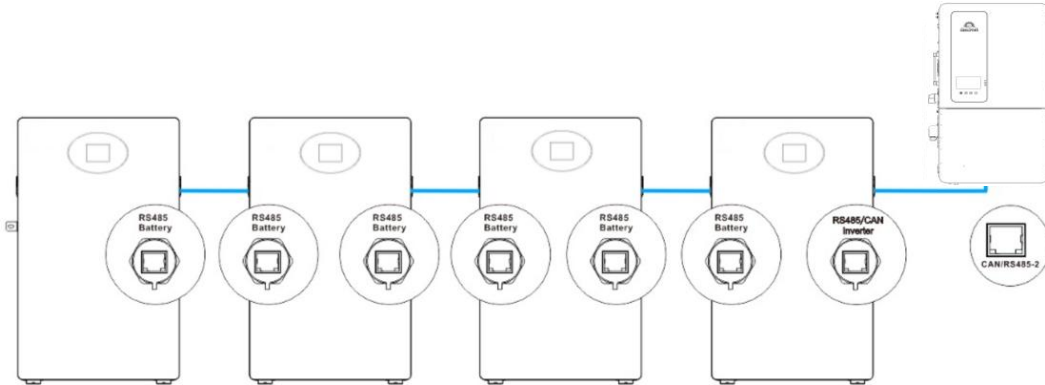

Multiple battery connections require assembly of the RJ45's waterproof connector, exploded view of RJ45 waterproof connector:



6.3.4 Energy Storage Battery Module Address Setting

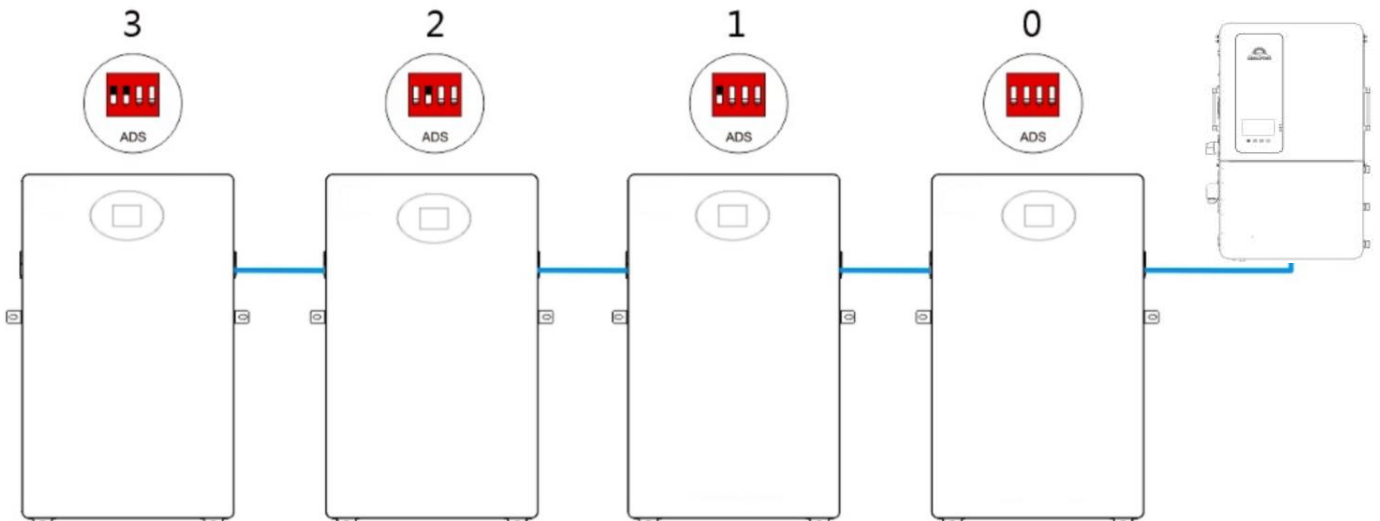

If multiple energy storage battery modules are used in parallel, the address of the energy storage battery module needs to be set. The address should be set as 0~8, and the address of each module cannot be repeated.



The address of the battery connected to the inverter must be set as 0.

Multiple batteries parallel DIP switch location description, up to 16 batteries can be used in parallel.

Addr.	DIP Switch Position	Master or Slave Battery	Connect the inverter
-------	---------------------	-------------------------	----------------------

0		Master	√
1		Slave1	×
2		Slave2	×
3		Slave3	×
4		Slave4	×
5		Slave5	×
6		Slave6	×
7		Slave7	×
8		Slave8	×
9		Slave9	×
10		Slave10	×
11		Slave11	×
12		Slave12	×
13		Slave13	×
14		Slave14	×
15		Slave15	×
 : off  : on			

7 System Debugging

7.1 Inspections Before Power-On

No	Inspection items	Acceptance criteria	Validation
1	The energy storage is installed in place	The installation is correct, secure and reliable.	<input type="checkbox"/> Yes <input type="checkbox"/> No
2	The installation environment meets requirements	The installation space is reasonable, and the environment is clean and tidy without any construction	<input type="checkbox"/> Yes <input type="checkbox"/> No
3	The power cord is correctly connected	The positive and negative terminals are connected correctly without any missing.	<input type="checkbox"/> Yes <input type="checkbox"/> No
4	The signal line is correctly connected	The signal line is connected reliably, and there is no wrong position	<input type="checkbox"/> Yes <input type="checkbox"/> No
5	The grounding is reliable	The grounding wire is correctly and reliably connected.	<input type="checkbox"/> Yes <input type="checkbox"/> No
6	The switch of the energy storage battery module is off	All switches connected to the energy storage are in the "OFF" state.	<input type="checkbox"/> Yes <input type="checkbox"/> No

7.2 Power-On of Battery Module

7.2.1 Power-up Sequence

After the battery is connected to the inverter, please power on in the following order.

First, turn on the breaker switch, if there are multiple battery modules, turn on all the breaker switches.

Secondly, turn on the battery switch button and the battery start to work. If there are multiple modules, please turn on the power switch one by one according to the address sequence.

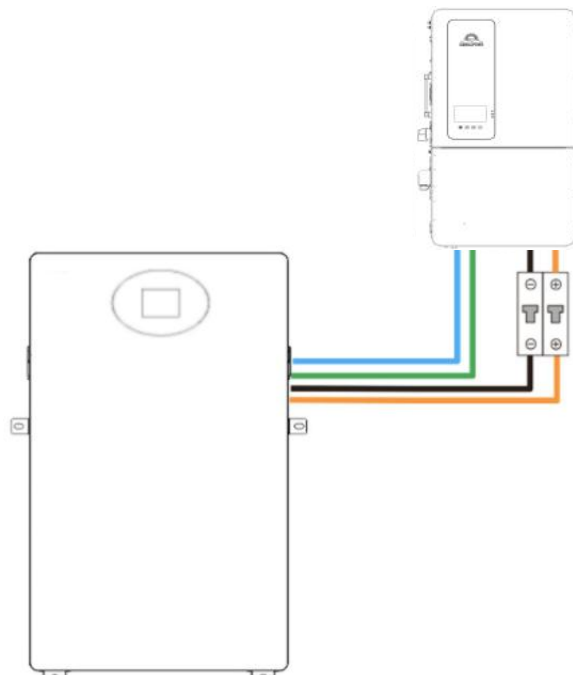

7.2.2 System Status Indication

After the battery switch button is turned on, the LED indicator will light up or flash. The meaning of the LED indicator is as follows.

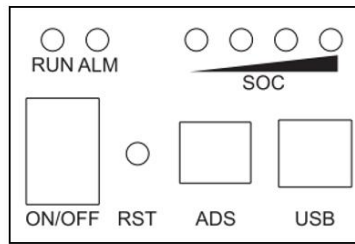

System Status	Events	RUN	ALM
POWER OFF	Power Off	OFF	OFF
Steady	Normal	Blinking1	OFF
	Alarm	Blinking1	Blinking3
Charging	Normal	ON	OFF
	Alarm	ON	Blinking3
	Over Charge Protection	ON	OFF
	High temperature, Over Current	OFF	ON
Discharging	Normal	Blinking3	OFF
	Alarm	Blinking3	Blinking3
	Over Discharge Protection	OFF	OFF
	Over Current, Short Current	OFF	ON

LED blinking description

Blinking	LED ON	LED OFF
Blinking1	0.25S	3.75S
Blinking2	0.5S	0.5S
Blinking3	0.5S	1.5S

7.2.3 Capacity indicator

Capacity indicator LED	SOC
	0~25%
	25~50%
	50~75%
	75~100%

7.2.4 LCD Touch Screen

7.2.4.1 Main Page

ID	Value
----	-------



①	Battery temperature
②	SOC
③	Charging indication
④	Discharge remain time

7.2.4.2 Warning Page



ID	Value
①	Battery voltage
②	Warning and Protection
③	Battery current

Warning and protection information is as follows.

1		Normal	
		Over voltage Warning	The battery voltage exceeds the warning value, but the BMS will not stop charging, and the inverter needs to actively stop charging.
		Over voltage Protection	The battery voltage exceeds the protection value, the BMS will actively stop charging.
2		Normal	
		Over discharge Voltage Warning	The battery voltage is lower than the warning value, but the BMS will not stop discharging, and the inverter needs to actively stop discharging.
		Over discharge Voltage Protection	The battery voltage is lower than the protection value, the BMS will actively stop discharging.
3		Normal	

		Over Temperature Warning	The battery temperature is higher than the warning value, but the BMS will not stop charging and discharging, and the inverter needs to actively stop charging and discharging.
		Over Temperature Protection	The battery temperature is higher than the protection value, the BMS will actively stop charging and discharging.
4		Normal	
		Low Temperature Warning	The battery temperature is lower than the warning value, but the BMS will not stop charging and discharging, and the inverter needs to actively stop charging and discharging.
		Low Temperature Protection	The battery temperature is lower than the protection value, the BMS will actively stop charging and discharging.
5		Normal	
		Short Circuit Protection	The battery output is short-circuit protected, and the BMS stops discharging.
6		Normal	
		Overcurrent Protection	The charging current or discharging current is too large, the BMS stops charging or discharging
7			Hardware failure, please stop using immediately, and contact a professional maintenance personnel to deal with.

7.2.4.3 Cell Voltage Page

ID	Value
①	Battery voltage

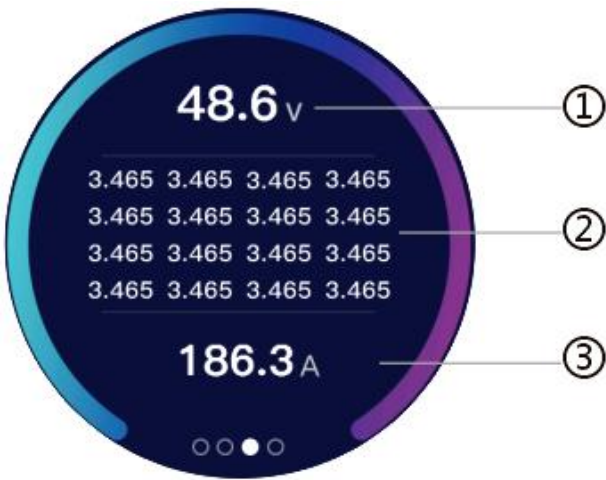

②	Cell voltage
③	Battery current

7.2.4.4 Information Page

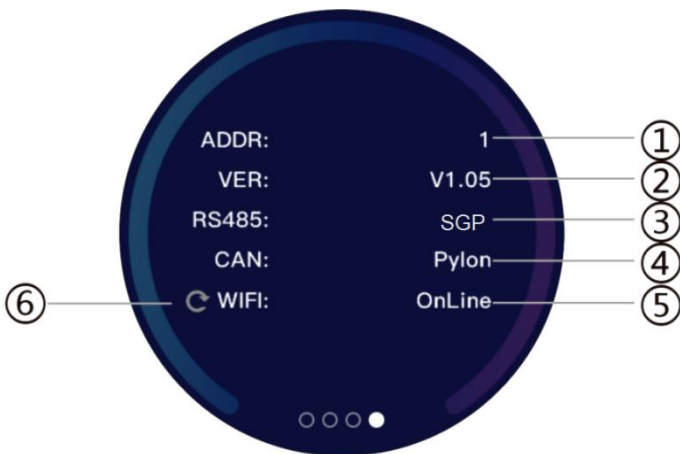

ID	Value
①	Battery address
②	Version
③	485 protocol connected with inverter
④	CAN protocol connected with inverter
⑤	WIFI status
⑥	Reset WIFI

If you can't connect to the network or need to change the network environment, please reset the WIFI.



7.3 Battery Communication Protocol

The supported inverter and battery manufacturer communication protocols are as follows, and will be continuously updated.

Battery /Inverter brand	CAN protocol	485 protocol
<i>Pylon</i>	√	√
<i>SUNGOLDPOWER</i>	√	√
<i>Growatt</i>	√	√
<i>Victron</i>	√	
<i>Goodwe</i>	√	
<i>Solis</i>	√	
<i>Luxpower</i>	√	
<i>Sofar</i>	√	
<i>KStar</i>	√	
<i>SMA</i>	√	
<i>MEGAREVO</i>	√	
<i>Afore</i>	√	
<i>Solark</i>	√	
<i>Voltronic</i>		√
<i>Paceic</i>		√

7.4 WIFI Function

7.4.1 Download App

Scan the QR code to download the APP.



7.4.2 Register and Login

You need to register an account for the first time.

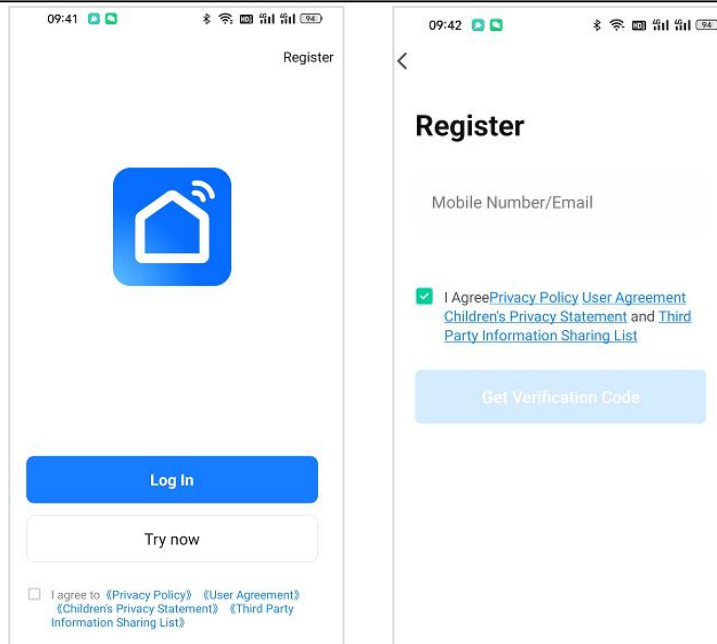

7.4.3 Add Device

Connecting the device requires turning on Bluetooth, WIFI, and location permissions.

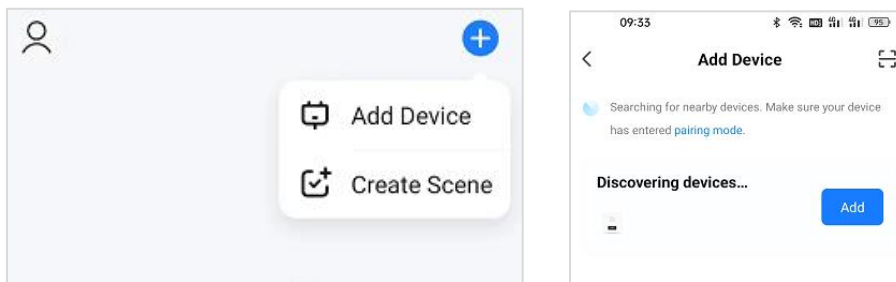

7.4.4 Connect Network

Choose WIFI and enter the password, the device starts connecting to the network.

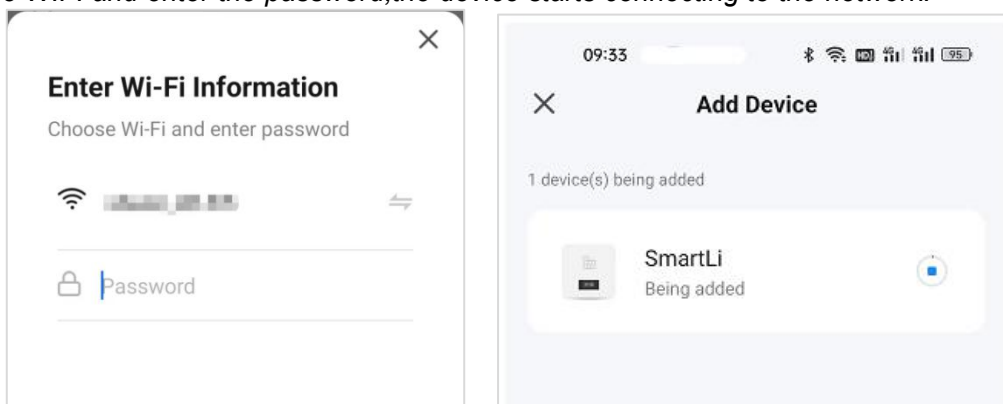

7.4.5 Reset WIFI

If you can't connect to the network or need to change the network environment, please reset the WIFI.



Only supports 2.4G band's WiFi , not supports 5G band's WiFi , please make sure that the 2.4G band of the router is turned on.

7.5 Sleep Mode

If the battery is neither charged nor discharged, it will automatically enter sleep mode after a period of time. After entering sleep mode, BMS will turn off LCD and WiFi module to save power. If you want to continue using it, please turn the power button on and off again.

8 System Maintenance

8.1 System Power-Off



After the system is powered off, the case still has residual power and heat, which may cause electric shocks or burns. Therefore, protective gloves should be worn before operating the energy storage 5 minutes after the system is powered off. Maintenance operations on energy storage should be performed only after ensuring that all indicator lights of the energy storage are off.

Power-off operation steps of the system:

Step 1 Turn off the breaker switch between the inverter and AC output (If installed).

Step 2 Turn off the breaker switch between the inverter unit and AC input (If installed).

Step 3 Turn off the breaker switch between the inverter unit and the PV string (If installed).

Step 4 Turn off the breaker switch between the inverter and battery.

Step 5 Turn off button on all storage battery modules, the energy storage is powered off successfully.

8.2 Routine Maintenance

To ensure the long-term and good operation of the energy storage system, it is recommended to perform the routine maintenance as described in this section.

Items	Methods	Maintenance interval
System cleanliness	Check if the radiator is covered or dirt on a regular basis.	Once every six months to one year.
Running status of system	<ul style="list-style-type: none"> Observe whether the energy storage appearance is damaged or deformed. Listen to whether the energy storage has any abnormal sound during running. When the energy storage is running, check whether the indicator of the energy storage battery is correct. 	Once every six months.
Electrical connection	<ul style="list-style-type: none"> Check if any cable connection is off or loose. Check if any cable is damaged, and especially if there are cuts on the sheath where the cable contacts with the metal surface. Check if the unused DC input terminals, energy storage terminals, COM ports, and covers are locked. 	Half a year after first debugging and testing, and once every six months to one year thereafter.

Grounding reliability	Check if the grounding cable is grounded reliably.	Half a year after first debugging and testing, and once every six months to one year thereafter.
-----------------------	--	--

8.3 Common Faults and Handling Methods

Faults	Handling measures
The indicator light and LCD does not work	Check whether battery is sleeping mode. If the battery is neither charged nor discharged, it will automatically enter sleep mode after a period of time.
All indicators of the battery are off	If the battery power is low, you need to charge it before using it. If the battery is not used for a long time, it will automatically sleep, and it can be used normally after restarting.
Battery overcurrent protection fault	Check whether there is a short circuit in the battery wiring. Check whether the load power exceeds the maximum
The battery cannot be charged	Check if the battery is fully charged Check whether the ambient temperature is below -10 degrees.
Communication error with inverter	Check whether the communication interface is incorrectly plugged in and Whether the wiring is secure. Whether the battery address is set correctly. Whether the protocol is secure.
WIFI communication error	Check if the router settings are correct Check whether the routing network is normal Check whether the router's 2.4G frequency band is turned on

8.4 Battery Storage and Maintenance

8.4.1 Battery Storage Requirements



Do not put the battery into fire. The battery may explode.

Do not open or damage the battery. The electrolyte flowing out from the battery is harmful to the skin and eyes. The electrolyte may also be toxic;

1. When being stored, the batteries shall be placed correctly in accordance with the marks on the packing case. Do not put them upside down or on the side.
2. When stacking up the battery packing cases, the stacking requirements on the outer package shall be met.
3. The batteries should be handled with care, and damage to batteries should be strictly prohibited.
4. Requirements for the storage environment:
 - Ambient temperature: -10°C to 55 °C, recommended storage temperature: 20°C to 30°C.
 - Relative humidity: 5%RH-80%RH.
 - Dry, well ventilated, and clean.
 - The corrosive organic solvents, gases and other substances shall be kept away.
 - Exposing to direct sunlight shall be avoided.

– The distance from the heat source should not be less than two meters.

5. When being stored, the battery shall be disconnected from the external connection. If there is an indicator light on the battery panel, the indicator light shall be off.

6. When the stored batteries are going to be delivered, the first-in first-out principle should be followed.

7. After the battery is produced and tested, it shall be recharged to at least 50% SOC before being stored. If the device will not be used for a long period of time, discharge the battery to 45% to 60% of the battery capacity and disconnect the battery output to avoid the battery runs out.

8. Do not touch the battery pack with wet hands.

9. Do not squeeze, drop, or pierce the battery.

10. The battery should always be disposed in accordance with local safety regulations.

11. The battery should be stored and recharged in accordance with this User's Manual.

12. Do not reverse polarity of the battery when storing or transporting the batteries, the batteries shall not be stacked up without protective packaging, and the number of stacked packed batteries should not exceed the number specified on the packaging.

13. All operators of the energy storage system shall comply with the user manual, installation and service manual, and quality assurance requirements. Any damage to the device resulting from neglecting or misreading of the user's manual, installation and service manual, and the quality assurance requirements will invalidate the product warranty.

8.4.2 Requirements for Charging of Battery

The batteries to be stored for a long period of time (unused, for more than 3 months) must be kept in a dry and cool place. The storage voltage is 51V~53V. The batteries should be stored in a clean environment of 23±2°C and humidity of 45%~75%. If the battery will be shelved and not used for a long period of time, it should be recharged every 3 months to ensure that the battery voltage is within the above range.

As for batteries and long-term storage, routine maintenance is required. Please charge the battery to 40% SOC at a current of 0.2C according to the requirements in the table below.

Ambient temperature for storage	Relative humidity for storage environment	Storage Time	SOC
<-10°C	/	Prohibited	/
-10~25°C	5%~70%	≤12 months	30%≤SOC≤60%
25~35°C		≤6 months	
35~45°C		≤3 months	
>45°C	/	Prohibited	/

8.5 Device Cleaning

It is recommended to clean and maintain the product from time to time. When cleaning, the dust and stains on the product shall be removed with a piece of soft dry cloth or vacuum cleaner. The product shall not be cleaned with organic solvents, corrosive liquids and other cleaning products.

9 Product Dimensions and Packaging

9.1 Product Dimensions

The external dimensions of the energy storage battery module , PowerMax 314 Outdoor is 1048*460*271mm.

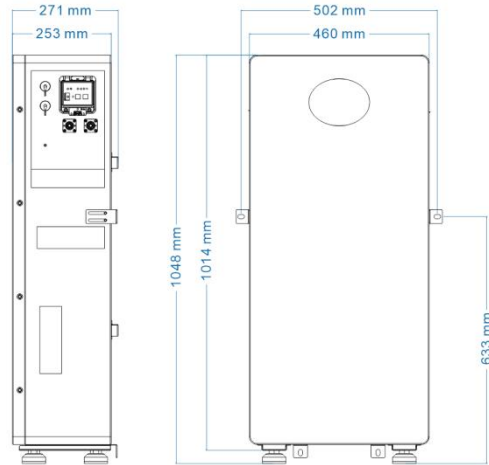

9.2 Package Dimensions

A single energy storage battery module. The packaging size of Power Max 314 Outdoor is 1170*600*510mm.

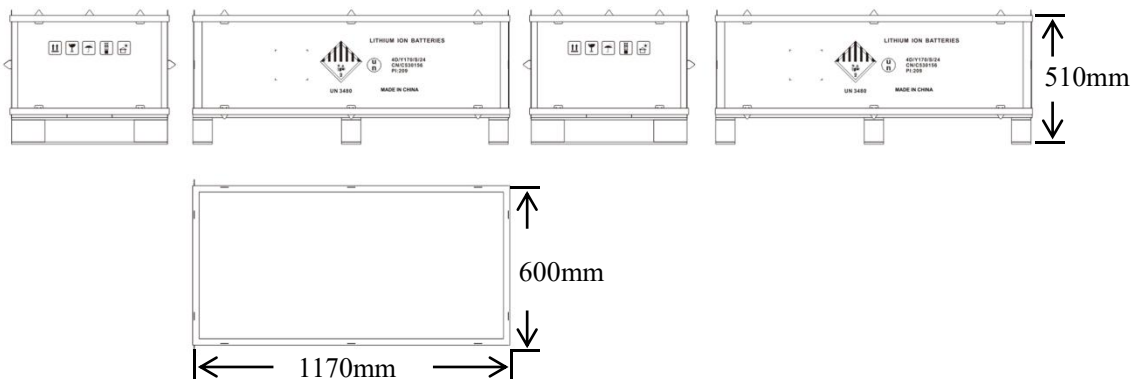



CONTACT US
(833)761-6080
support@sungoldpower.com

Mono Power: 415W
Dimensions: 1722*1134*35mm



Characteristics

- High efficiency solar cell to keep the modules efficiency reach to 21.25%.
- Positive tolerance to ensure higher output.
- Excellent performance under weak light conditions.
- Modules withstand extremely (temperature, load and impact) TUV certification.
- All modules combination and packing through stepping current to keep effectively reduce mismatch loss.
- 100% EL test to keep higher quality.

Warranty

- 5 year 95% output warranty, 10 year 90% output warranty, 25 year 80% output warranty.
- 12 years material and workmanship warranty.



Anodized aluminum frame withstand corrosion and damage, Special osculum can reduce destruction by water freeze.

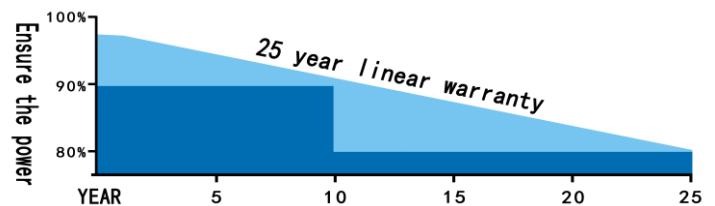

IP68 junction box long-term weather endurance.

Quality and safety

- ISO9001:2015、ISO14001:2015、ISO45001:2018 certified supplier, we provide world first class solar products for clients.
- TUV,IEC,CEC,CE,CB CA 92618 approved.
- *UL61730, CEC Listed.*



Electrical Characteristics

Model No.	SG415WM
Maximum Power (Pmax)	415W
Max-power Voltage (Vmp)	31.11V
Max-power Current (Imp)	13.34A
Open-circuit Voltage (Voc)	38.32V
Short-circuit Current (Isc)	14.09A
Module Efficiency	21.3%
Operating Temperature	-40 ℉ to 185 ℉ -40℃ ~+85℃
Maximum System Voltage	1500Vdc
Maximum Series Fuse Rating	20A
Power Tolerance	±3%

*STC condition: 1000 W/m², 1.5AM and 25℃ cell temperature.

Temperature Characteristics

NMOT	45℃±2℃
Temperature Co-efficient of Pmax	-0.35%/℃
Temperature Co-efficient of Voc	-0.27%/℃
Temperature Co-efficient of Isc	0.048%/℃

Mechanical Characteristics

Mono Power	415W
Cell Type	Mono 182*91mm
Cell Arrangement	108(6*18)
Dimensions	67.80*44.65*1.38inch(1722*1134*35mm)
Weight	48.06lb
Front Cover	3.2mm tempered glass
Frame Material	Anodized aluminium alloy
Junction Box	IP68 rated
Output Cables	4mm ² , Length: (+) 300mm/ (-) 300mm

Packing

Packing	40HC
Pieces/Pallet	32
Pieces/container	780

I-V Curve

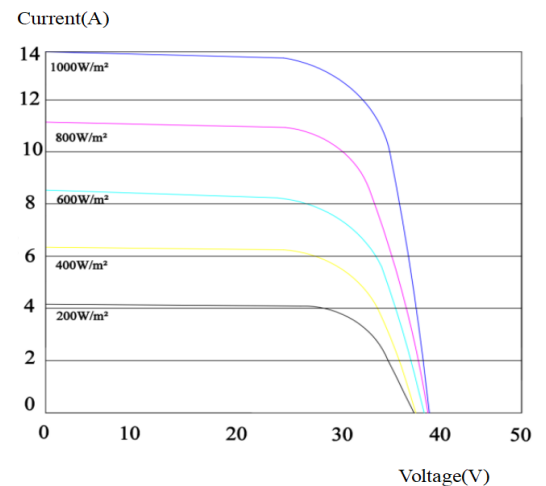

Dimensions

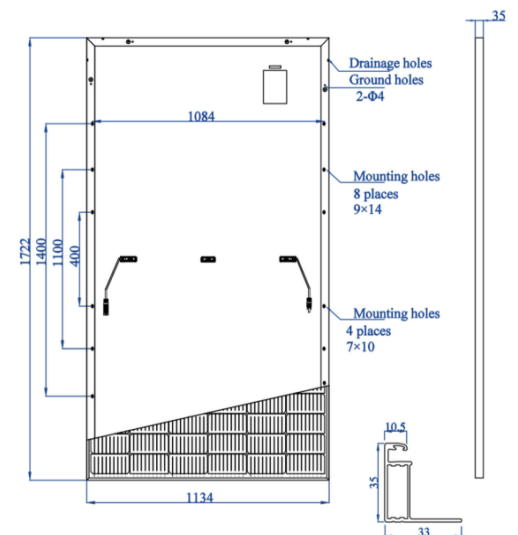

Battery system home storage series

User Manual



ProductName: 48V100Ah Lithium Battery

ProductModel: SG48100P

ProductSpecifications: 51.2V 100Ah

Catalogue

1. Document description	3
2. Definition of Terms	3
3. Battery system performance parameters	3
4. Outline and Structural Dimensions of Battery System	5
5. Definition of battery system interface	6
5.1. Panel Schematic	6
5.2. Module Panel Description	6
6. Functional block diagram	7
7. Battery Management System Specifications	7
7.1. Basic parameter settings	7
7.2. Interface	10
7.2.1. Interface diagram	10
7.2.2. Interface Definition	11
7.3. Communication description	12
7.3.1. RS232 communication	12
7.3.2. RS485 communication	12
7.3.3. CAN communication	12
8. Product function and performance description	13
8.1. Charging performance	13
8.2. Discharging performance	13
9. Using & Maintenance Suggestions	14
9.1. LED indication description	14
9.2. Buzzer action description	15
9.3. Key Description	15
9.4. Sleep and wake up	16
9.4.1. hibernate	16
9.4.2. wake	16
9.5. DIP switch settings	17
9.6. The routine maintenance of the battery part can be carried out by referring to the table	18
10. Packing List	18
11. Storage, maintenance and transportation	19
11.1. Storage	19
11.2. Transportation	19
12. Maintain	19
13. Battery usage precautions	19
14. Product Liability	20

1. Document description

This specification covers the performance indexes, technical requirements and safety issue of the 48V100Ah

2. Definition of Terms

BMS	Battery Management System
DOD	Depth Of Discharge
EOL	End Of Life
OCV	Open Circuit Voltage
SOC	State Of Charge
SOH	State Of Health
EMC	Electro Magnetic Compatibility
Nominal voltage	Appropriate voltage approximation to identify or identify a cell or an electrochemical system.
Capacity	(The amount of power a battery can provide when fully charged under specified conditions. Usually expressed in Ah.)
Energy	The energy that can be provided by a fully charged battery under specified conditions. Usually expressed in Wh or kWh.
Unit	“V” (Volt) (Voltage unit) “A” (Ampere) (Current unit) “Ah” (Ampere-Hour) (unit of charge) “Wh” (Watt-Hour) (electrical energy unit) “Ω” (Ohm) (resistance unit) “ °C” (degree Celsius) (temperature unit) “mm” (millimetre) (length unit) “s” (second) (Time unit) “kg” (kilogram) (Weight unit) “Hz” (Hertz) (Frequency unit)

3. Battery system performance parameters

No.	Item	Technical parameter	Note
1	Battery Type	Lithium iron phosphate battery	/
2	Rated capacity	100Ah	@25°C±2, 0.5C, 100%DOD
3	Nominal voltage	51.2V	
4	Recommended charging voltage	54.5V	
5	Charging Limited Voltage	42V	
6	SOC working range	0~100%	Recommended range of use: 20%~95%
7	Standard discharge current	50A	

8	Maximum continuous discharge current	100A	
9	Standard charging current	50A	
10	Maximum continuous charge current	100A	
11	Maximum cut-off voltage for charging	57.6V	
12	Charge cut-off current	5A	0.05C magnification
13	Discharge cut-off voltage	43.2V	
14	PACK cycle life	≥7000	80%DOD 25°C±2°C, 0.5C charge/0.5C discharge
15	Thermal management method	Natural heat dissipation	
16	IP protection class	IP31 battery box	
17	Flammability rating	plastic parts UL94 V-0	
18	Total system mass	Around 43KG	
19	Battery system shell material	BLACK Q235A	Color can be customized
20	Shipping SOC	SOC45-55%	
21	Dimension (L*W*H mm)	☑442*460*133 (3U) ±1mm	
22	Design life	15 Year	
23	Parallel function	Supports up to 32 batteries in parallel	
24	Anti-theft function	sensor G-sensor anti-theft function	
25	Display function	English smart display	
26	Charging current limit function	Current limit 20A	Charging current limit can be set according to customer requirements
27	Communication mode	☑RS232	Communication mode can be set according to customer requirements
		☑RS485	
		☑CAN	
28	communication protocol	Support multiple protocols	Communication protocol can be set according to customer requirements
29	Storage ambient temperature	-10~+45°C	Recommended storage temperature: 0~+30°C
30	Working temperature	Battery charging:0~45°C Battery discharging:-20~ +60°C	
31	Relative humidity of working environment	≤95	Best Use Relative Humidity: ≤85%

4. Outline and Structural Dimensions of Battery System

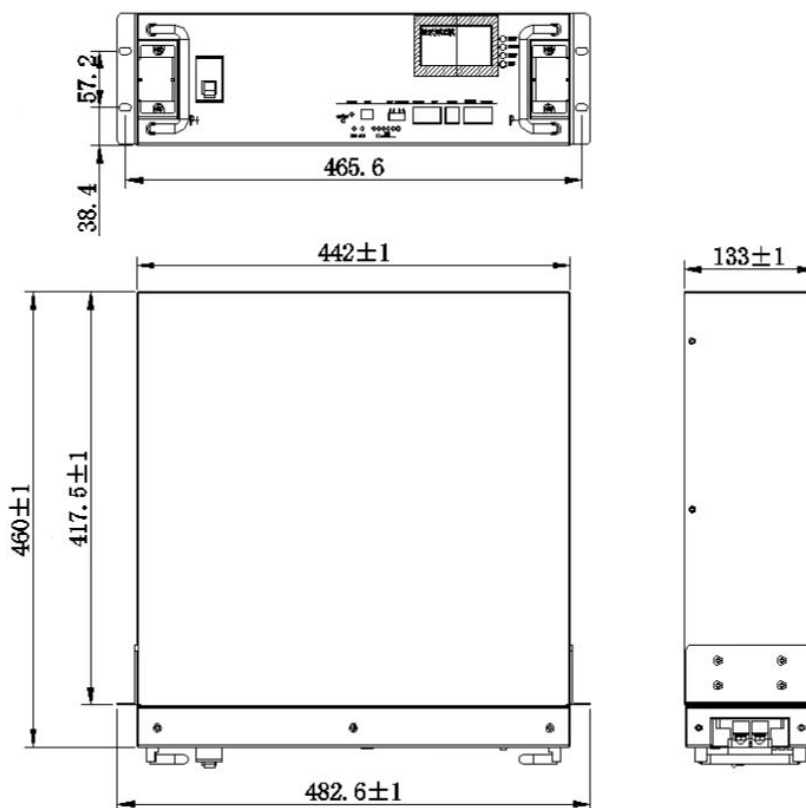

5. Definition of battery system interface

5.1. Panel Schematic

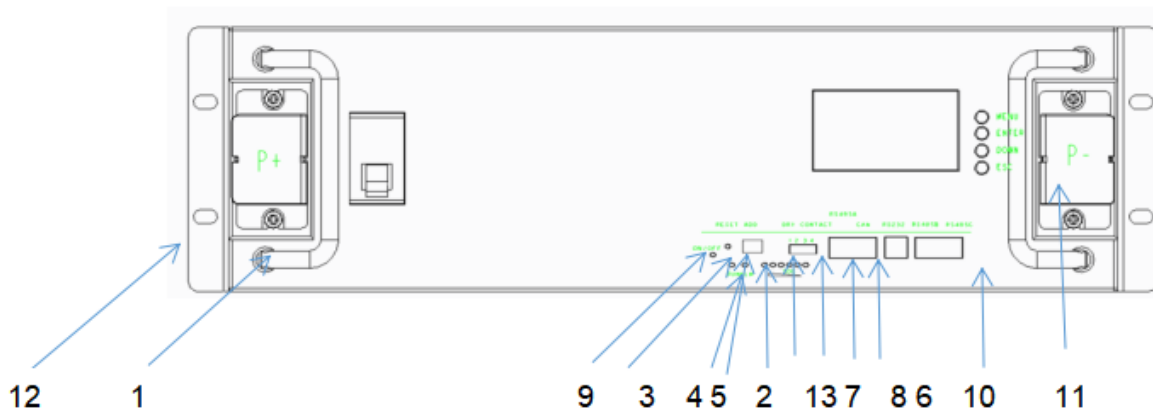

5.2. Module Panel Description

NO	Function definition	Function Description	Note
1	handle	Carrying handle	
2	SOC	Capacity status light	Six green LED lights to show the current charge of the lithium battery pack
3	ALM	Alert	Red LED light, normally off under normal conditions, always on under fault conditions, and a voice prompt
4	RUN	Run	Green light, always on when the product is running
5	ADD	DIP switch	Use 4 bit binary DIP switch (optional) to set address allocation when products are used in parallel,
6	RS232	RS232 communication	Uplink communication port, RS232 communication mode when uploading data, data content includes system parameters, system status and alarm information. The rate of 9600bps is generally used. Note: Wiring definitions are implemented in accordance with BMS product specifications
7	RS485	RS485 communication	RS485 communication method
8	CAN	CAN communic	CANcommunication method
9	RESET	Reset	When the product is in an abnormal state or in a hibernation state, the product can be restarted and woken up through the reset button to ensure the stable operation of the system
10	Main panel	Shell	Sheet metal thickness 1.5mm, galvanized frosted paint, color: black
11	Terminals	Input and output terminals	Battery positive and negative output terminals
12	Hanging ears	Mounting ears	The spacing is implemented according to the national standard
13	dry contact terminal	Load output port	example: definition: Dry contact 1-PIN1 to PIN2: normally open, closed during fault protection Dry contacts 2-PIN3 to PIN4: normally open, SOC<5%, closed for low battery alarm.

6. Functional block diagram

The functional block diagram is shown in the figure below

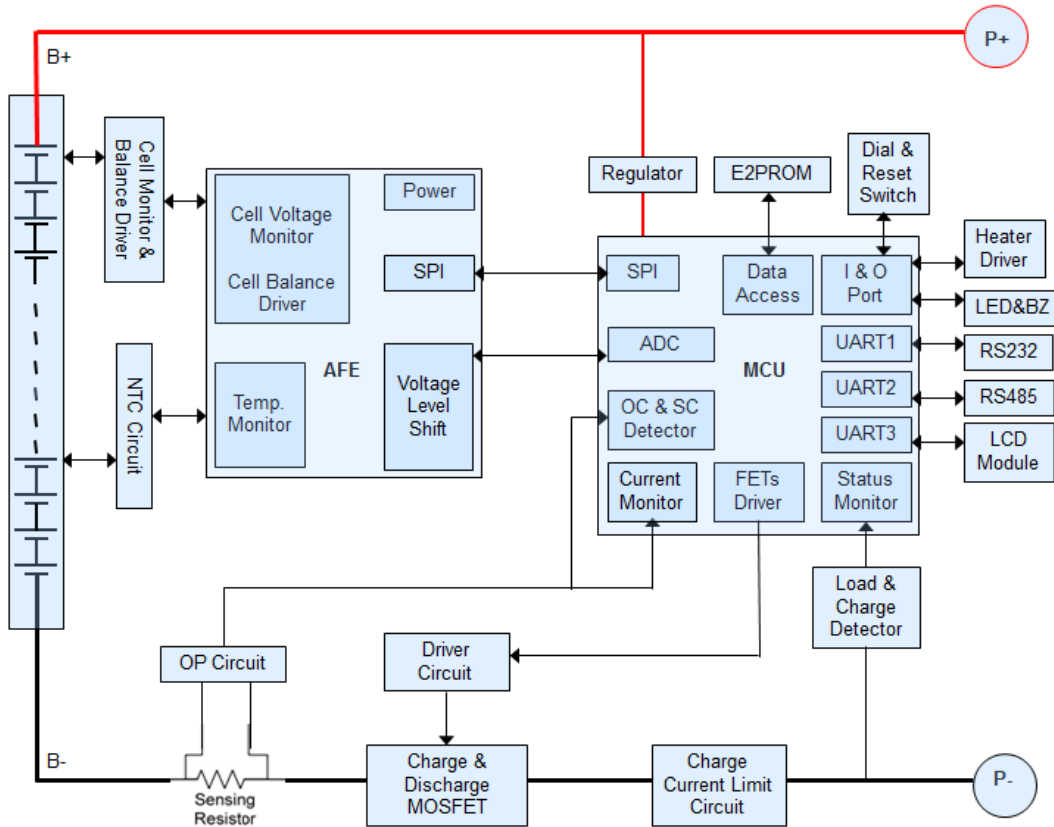

7. Battery Management System Specifications

7.1. Basic parameter settings

NO.	Indicator item		Factory default parameters	Is it possible to set	Note
1	Cell overcharge protection	Cell overcharge alarm voltage	3600mV	Can be set	
		Cell overcharge protection voltage	3650mV	Can be set	
		Cell overcharge protection delay	4.0S	Can be set	
	Single Overvoltage Protection Released	overcharge protection release voltage Cell	3380mV	Can be set	
		Capacity release	SOC < 96%	Can be set	
		Discharge release	> 1A		
2	Cell over-discharge protection	Cell over-discharge alarm voltage()	2700mV	Can be set	After 30 seconds of over-discharge protection, if it still cannot recover, it will enter low
		Cell over-discharge protection voltage	2500mV	Can be set	
		Monomer over-discharge protection delay	1.0S	Can be set	
	Cell over-discharge	Cell over-discharge protection release voltage	2800mV	Can be set	

	protection released	(Release when charging)	Plug into the charger to activate		power consumption mode
3	Overall overcharge protection	Overall overcharge warning voltage	57.6V	Can be set	
		Overall overcharge protection voltage	58.4V	Can be set	
		Overall overcharge protection delay	1.0S	Can be set	
	Overall overvoltage protection released	Overall overcharge protection release voltage	54.1V	Can be set	
		Capacity release	SOC<96%	Can be set	
		Discharge release	> 1A Discharge current > 1A		
4	Overall overdischarge protection	Overall over-discharge warning voltage	43.2V	Can be set	After 30 seconds of over-discharge protection, if it still cannot recover, it will enter low power consumption mode
		Overall over-discharge protection voltage	40V	Can be set	
		Overall over-discharge protection delay	1.0S	Can be set	
	Overall over-discharge protection released	Overall over-discharge protection release voltage	44.8V	Can be set	
		Release when charging	Plug into the charger to activate		
	Charging current limit function	Charging current limit	20A		
5	Charge overcurrent protection	Charge overcurrent 1 alarm current	105A	Can be set	Appearing 10 times in a row will lock the status and will no longer automatically release
		Charge overcurrent 1 protection current	110A	Can be set	
		Charge overcurrent 1 protection delay	1.0S	Can be set	
	Charging overcurrent 1 protection released	Automatic release)	1min Automatically cancel after 1min		
		Discharge release	> 1A Discharge current > 1A		
6	Discharge overcurrent 1 protection	Discharge overcurrent 1 alarm current)	105A	Can be set	Appearing 10 times in a row will lock the status and will no longer automatically release
		Discharge overcurrent 1 protection current)	110A	Can be set	
		Discharge overcurrent 1 protection delay	1.0S	Can be set	
	Discharge overcurrent 1 protection released	Automatic release	1min Automatically cancel after 1min		
		Charge release	> 1A Charge current > 1A		
7	Discharge overcurrent 2	Discharge overcurrent 2 protection current	≥120A	Can be set	Appearing 10 times in a row will lock the status and will no longer automatically
		Discharge overcurrent 2 protection delay	100mS	Can be set	
	Discharge	Automatic release	1min		

	overcurrent 2 protection released		Automatically cancel after 1min	release
		charge release	> 1A Charge current > 1A	
8	Short circuit protection	Short circuit protection function	(Have)	
		Short circuit protection current	/	
		Short circuit protection delay	/	
		Short circuit protection released	When there is charging, the short circuit protection is released After the load is removed, it will automatically disarm	
9	MOS high temperature protection	MOS over temperature alarm temperature)	90°C	Can be set
		MOS over temperature protection temperature)	115 °C	Can be set
		MOS protection release temperature)	85°C	Can be set
10	Cell temperature protection	Charging low temperature warning temperature)	0°C	Can be set
		Charging low temperature protection temperature)	-5°C	Can be set
		Charging low temperature protection release temperature	0°C	Can be set
		Charging high temperature alarm temperature	55°C	Can be set
		Charging high temperature protection temperature)	60°C	Can be set
		Charging high temperature protection release temperature	50°C	Can be set
		Discharge low temperature alarm temperature	-15°C	Can be set
		Discharge low temperature protection temperature	-20°C	Can be set
		(Discharge low temperature protection release temperature	-15°C	Can be set
		Discharge high temperature alarm temperature	60°C	Can be set
		Discharge high temperature protection temperature	65°C	Can be set
Discharge high temperature protection release temperature	55°C	Can be set		
11	Ambient temperature alarm	Ambient low temperature alarm temperature	-15°C	Can be set
		Ambient low temperature protection temperature	-20°C	Can be set
		Ambient cryogenic protection release temperature	-15°C	Can be set
		Ambient high temperature alarm temperature	65°C	Can be set
		Ambient high temperature protection temperature	75°C	Can be set
		Ambient high temperature protection release	65°C	Can be set

		temperature			
12	Current consumption	Self-consumption current during operation	$\leq 45\text{mA}$ ((with display)		
			$\leq 40\text{mA}$ (without display)		
		Low power mode current	$\leq 200\mu\text{A}$		
13	Equalization function	Equalization turn-on voltage	3500mV	Can be set	
		Open differential pressure	30mV	Can be set	
14	Capacity default settings	Low battery warning	SOC<5%	Can be set	(No alarm when charging)
		Full capacity setting	100AH	Can be set	
15	Sleep function	Sleep voltage	3150mV	Can be set	
		Delay	5min	Can be set	
16	Differential pressure alarm	Overpressure alarm	800mV		
		Overpressure recovery	500mV		
17	Cell failure protection	Monomer differential pressure	$> 1\text{V}$ Voltage difference $>1\text{V}$		Charge and discharge are not allowed
18	Full charge judgment	Full charge voltage	56V		
		Cut off current	5A		

7.2. Interface

7.2.1. Interface diagram

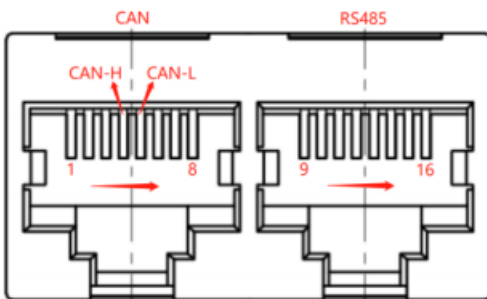

CAN and RS485 interface



1 2 3 4

dry contact

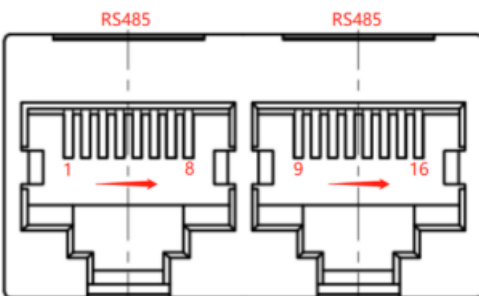

Parallel communication port

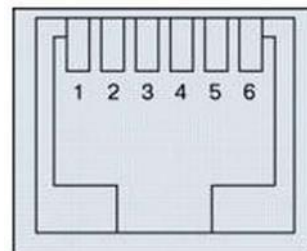

RS232 communication interface

7.2.2. Interface Definition

RS232--Using 6P6C vertical RJ11 socket	
RJ11	Definition description
1、 2、 6	NC
3	TX
4	RX
5	GND

RS485 and CAN interface

RS485--Using 8P8C vertical RJ45 socket		CAN--Using 8P8C vertical RJ45 socket	
RJ45 Pin	Definition description	RJ45 Pin	Definition description
9、 16	RS485-B1	1、 2、 3、 6、 8	NC
10、 15	RS485-A1	4	CAN-H
11、 14	GND	5	CAN-L
12、 13	NC	7	GND

Parallel communication port

RS485--Using 8P8C vertical RJ45 socket		RS485--Using 8P8C vertical RJ45 socket	
RJ45Pin	Definition description	RJ45 Pin	Definition description
1、 8	RS485-B	9、 16	RS485-B
2、 7	RS485-A	10、 15	RS485-A
3、 6	GND	11、 14	GND
4、 5	NC	12、 13	NC

7.3. Communication description

7.3.1. RS232 communication

The BMS can communicate with the host computer through the RS232 interface, so as to monitor various information of the battery on the host computer side, including battery voltage, current, temperature, status, SOC, SOH and battery production information, etc. The default baud rate is 9600bps.

7.3.2. RS485 communication

With dual RS485 interface, you can view the information of PACK, the default baud rate is 9600bps. To communicate with the monitoring device through RS485, the monitoring device is used as the host to poll data according to the address, and the address setting range is 2~15.

7.3.3. CAN communication

CAN communication, baud rate 500K.

8. Product function and performance description

8.1. Charging performance

- ◆ Standard charging current (25°C) : example:0.2C (20A)
- ◆ Standard charging voltage: 54V
- ◆ Standard charging mode and charging curve:

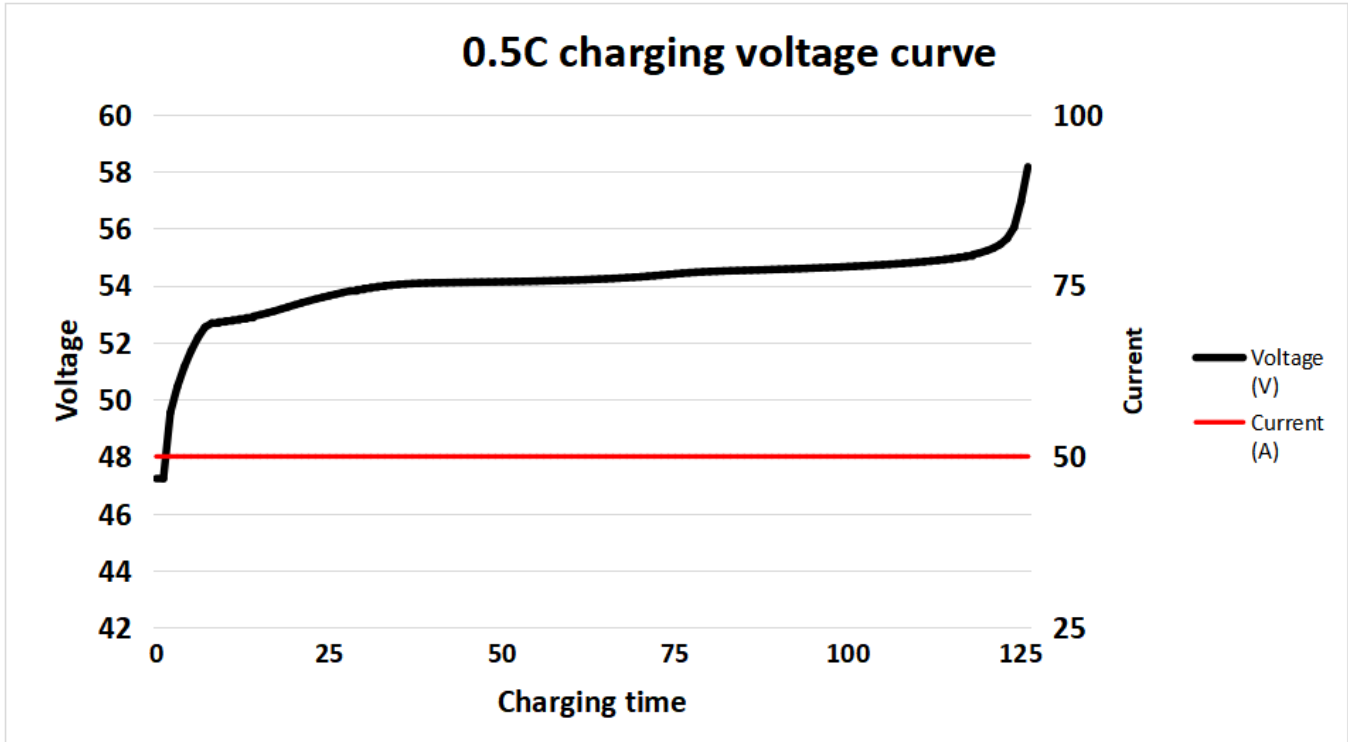

8.2. Discharging performance

Discharge curve at different magnification

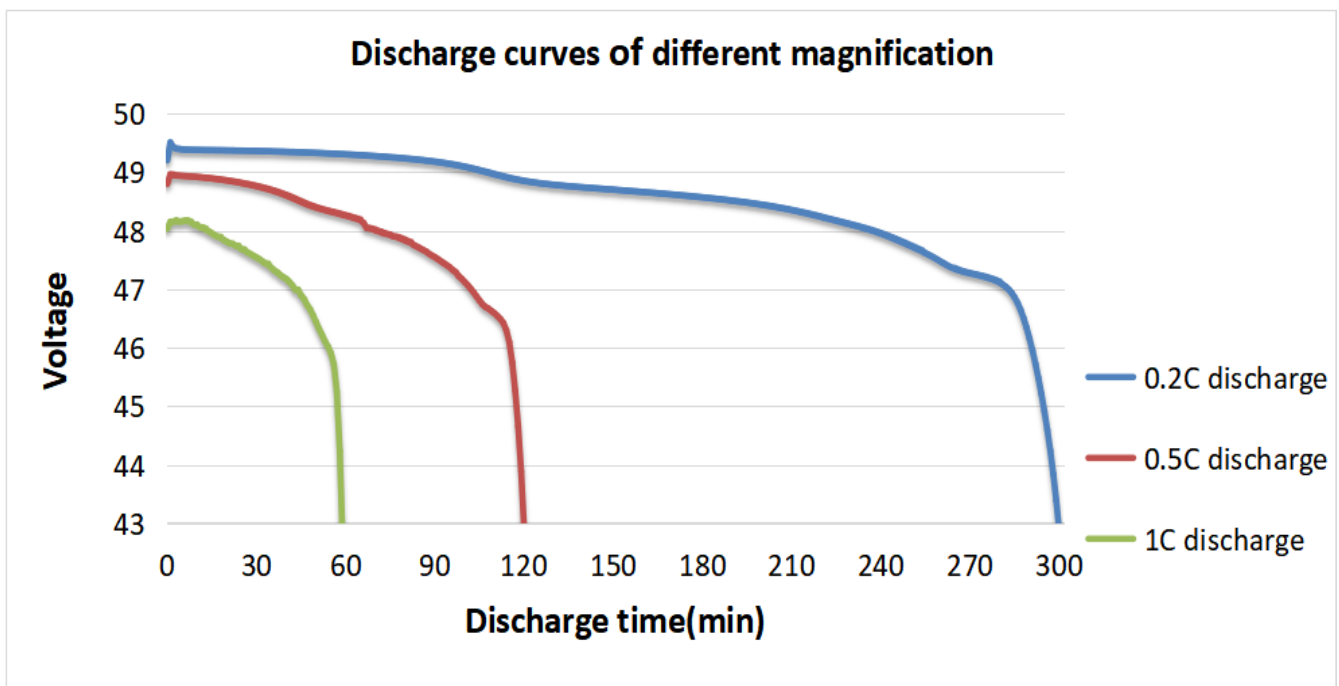

9. Using & Maintenance Suggestions

9.1. LED indication description

Table 1 LED working status indication

Condition	Normal/Alarm/Protect	RUN	ALM	LED Battery indicator LED						Illustrate	
		●	●	●	●	●	●	●	●		
Shutdown	Hibernate	black	black	black	black	black	black	black	black	black	Annihilate
Standby	Normal	flash1	black	According to the battery indicator						Standby mode	
	Alarm	flash1)	flash3							Module low voltage	
Charging	Normal	Always bright)	black	According to the battery indicator (battery indication maximum LED flashes 2)						(The highest power LED flashes (flashing 2), the overcharge alarm ALM does not flash)	
	Alarm	Always bright	3 flash3								
	Overcharge protection	Always bright	black	Always bright	Always bright	Always bright	Always bright	Always bright	Always bright	(If there is no utility power, the indicator light is in standby state)	
	Temperature, overcurrent, fail safe	black	Always bright	black	black	black	black	black	black	black	Stop charging
Discharging	Normal	flash3	black	(According to the battery indicator)							
	Alarm	flash3)	flash3								
	Undervoltage protection	black	black	black	black	black	black	black	black	black	Stop discharge
	Temperature, overcurrent, short circuit, reverse connection, fail safe	black	Always bright	black	black	black	black	black	black	black	Stop discharge
Invalid		black	Always bright	black	black	black	black	black	black	black	Stop charging and discharging

Table 2 Description of capacity indication

Condition	Charging							Discharging						
	L6●	L5●	L4●	L3●	L2●	L1●	L6●	L5●	L4●	L3●	L2●	L1●		
Electricity (%)	0~17%	black	black	black	black	black	flash2	black	black	black	black	black	black	Always bright
	17~33%	black	black	black	black	flash 2	Always bright	black	black	black	black	black	Always bright	Always bright
	33~50%	black	black	black	flash 2	Always bright	Always bright	black	black	black	black	Always bright	Always bright	Always bright

	50~66%	black	black	flash 2	Always bright	Always bright	Always bright	black	black	Always bright	Always bright	Always bright	Always bright
	66-83%	black	flash 2	Always bright	Always bright	Always bright	Always bright	black	Always bright	Always bright	Always bright	Always bright	Always bright
	83-100%	flash 2	Always bright	Always bright	Always bright	Always bright	Always bright	Always bright	Always bright	Always bright	Always bright	Always bright	Always bright
Running lights●				Always bright						flash3			

Table 3 LED flashing description

Flashing method	Bright	Black
flash 1	0.25S	3.75S
flash 2	0.5S	0.5S
flash 3	0.5S	1.5S

Note:

The LED indicator alarm can be enabled or disabled through the host computer, and the factory default is enabled.

9.2. Buzzer action description

- 1) In case of failure, it will beep for 0.25S every 1S;
- 2) During protection, it will beep for 0.25S every 2S (except for overvoltage protection);
- 3) When alarming, it will beep every 3S for 0.25S (except overvoltage alarm);
- 4) The buzzer function can be enabled or disabled by the host computer, and the factory default is disabled.

9.3. Key Description

- 1)When the BMS is in the dormant state, press the button (3~6S) and release it, the protection board will be activated, and the LED indicators will light up in sequence from "RUN" for 0.5 seconds.
- 2)When the BMS is activated, press the button (3~6S) and release it, the protection board is put to sleep, and the LED indicators light up sequentially for 0.5 seconds from the lowest battery light.
- 3)When the BMS is activated, press the button (6~10S) and release it, the protection board will be reset, and all the LED lights will light up at the same time for 1.5 seconds.

After the BMS is reset, it still retains the parameters and functions set by the host computer. If it is necessary to restore the initial parameters, it can be achieved through the "restore default value" of the host computer, but the relevant operation records and stored data remain unchanged (such as power, cycle times, etc.). , protection records, etc.).

9.4. Sleep and wake up

9.4.1. hibernate

When any of the following conditions are met, the system enters a low-power mode:

1. The single or overall over-discharge protection has not been released within 30 seconds.
2. Release the button after pressing the button for 3 seconds.
3. The minimum cell voltage is lower than the sleep voltage, and the duration reaches the sleep delay time (at the same time, no communication, no protection, no balance, and no current are satisfied).
4. The standby time is more than 24 hours (no communication, no charging and discharging, no mains power).
5. Forced shutdown through the host computer software. Before entering the sleep mode, make sure that the input terminal is not connected to an external voltage, otherwise it will not be able to enter the low power consumption mode.

9.4.2. wake

When the system is in low-power mode and meets any of the following conditions, the system will exit the low-power mode and enter the normal operation mode:

1. Connect the charger, the output voltage of the charger must be greater than 48V.
2. Press the button for 3S and release the button.
3. Connect to the communication line and open the software of the upper computer (it enters the sleep state due to over-discharge protection, this method cannot wake up the protection board).

Remarks:

After the single or overall over-discharge protection, it enters the low-power mode, wakes up regularly every 4 hours, and turns on the charge and discharge MOS. If it can be charged, it will exit the dormant state and enter normal charging; if it cannot be charged after 10 consecutive automatic wake-ups, it will no longer automatically wake up.

When the system is defined as the end of charging, the recovery voltage is not reached after 2 days of standby (standby time setting value), and the charging is forced to resume until the end of charging again.

9.5. DIP switch settings

When the battery packs are used in parallel, different PACK can be distinguished by their hardware addresses, and the hardware address of each PACK in the entire battery stack is unique. The hardware addresses can be set in sequence through the DIP switches on the board. Refer to the following for the definition of the switches. surface.

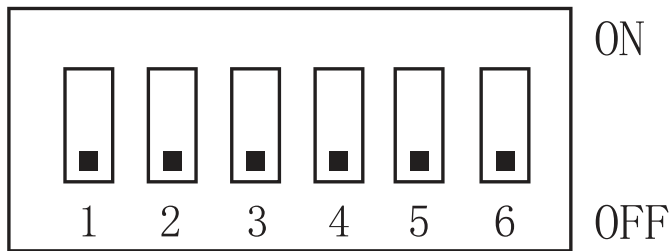

Add	Address Code					
	#1	#2	#3	#4	#5	#6
1	ON	OFF	OFF	OFF	OFF	OFF
2	OFF	ON	OFF	OFF	OFF	OFF
3	ON	ON	OFF	OFF	OFF	OFF
4	OFF	OFF	ON	OFF	OFF	OFF
5	ON	OFF	ON	OFF	OFF	OFF
6	OFF	ON	ON	OFF	OFF	OFF
7	ON	ON	ON	OFF	OFF	OFF
8	OFF	OFF	OFF	ON	OFF	OFF
9	ON	OFF	OFF	ON	OFF	OFF
10	OFF	ON	OFF	ON	OFF	OFF
11	ON	ON	OFF	ON	OFF	OFF
12	OFF	OFF	ON	ON	OFF	OFF
13	ON	OFF	ON	ON	OFF	OFF
14	OFF	ON	ON	ON	OFF	OFF
15	ON	ON	ON	ON	OFF	OFF
16	OFF	OFF	OFF	OFF	ON	OFF
17	ON	OFF	OFF	OFF	ON	OFF
18	OFF	ON	OFF	OFF	ON	OFF
19	ON	ON	OFF	OFF	ON	OFF
20	OFF	OFF	ON	OFF	ON	OFF
21	ON	OFF	ON	OFF	ON	OFF

22	OFF	ON	ON	OFF	ON	OFF
23	ON	ON	ON	OFF	ON	OFF
24	OFF	OFF	OFF	ON	ON	OFF
25	ON	OFF	OFF	ON	ON	OFF
26	OFF	ON	OFF	ON	ON	OFF
27	ON	ON	OFF	ON	ON	OFF
28	OFF	OFF	ON	ON	ON	OFF
29	ON	OFF	ON	ON	ON	OFF
30	OFF	ON	ON	ON	ON	OFF
31	ON	ON	ON	ON	ON	OFF
32	OFF	OFF	OFF	OFF	OFF	ON
33	ON	OFF	OFF	OFF	OFF	ON
34	OFF	ON	OFF	OFF	OFF	ON
35	ON	ON	OFF	OFF	OFF	ON
36	OFF	OFF	ON	OFF	OFF	ON
37	ON	OFF	ON	OFF	OFF	ON
38	OFF	ON	ON	OFF	OFF	ON
39	ON	ON	ON	OFF	OFF	ON
40	OFF	OFF	OFF	ON	OFF	ON
41	ON	OFF	OFF	ON	OFF	ON
42	OFF	ON	OFF	ON	OFF	ON
43	ON	ON	OFF	ON	OFF	ON
44	OFF	OFF	ON	ON	OFF	ON
45	ON	OFF	ON	ON	OFF	ON
46	OFF	ON	ON	ON	OFF	ON
47	ON	ON	ON	ON	OFF	ON
48	OFF	OFF	OFF	OFF	ON	ON
49	ON	OFF	OFF	OFF	ON	ON
50	OFF	ON	OFF	OFF	ON	ON
51	ON	ON	OFF	OFF	ON	ON
52	OFF	OFF	ON	OFF	ON	ON
53	ON	OFF	ON	OFF	ON	ON
54	OFF	ON	ON	OFF	ON	ON
55	ON	ON	ON	OFF	ON	ON
56	OFF	OFF	OFF	ON	ON	ON
57	ON	OFF	OFF	ON	ON	ON
58	OFF	ON	OFF	ON	ON	ON
59	ON	ON	OFF	ON	ON	ON
60	OFF	OFF	ON	ON	ON	ON
61	ON	OFF	ON	ON	ON	ON
62	OFF	ON	ON	ON	ON	ON
63	ON	ON	ON	ON	ON	ON

9.6. The routine maintenance of the battery part can be carried out by referring to the table

Period	Item	Treatment measures
Per month	(Operating environment)	Keep away from heat sources and avoid direct sunlight
	Visual inspection	If the appearance is damaged, leaked or deformed, the faulty battery pack should be disconnected, photographed and replaced.
Each quarter	Clean appearance	Clean the exterior with a cotton cloth. Due to the high voltage of the battery pack, care should be taken when cleaning.
	Connection Status	<ul style="list-style-type: none"> ● Check the bolts at each terminal and retighten them if they are loose. ● If the temperature of the connection line exceeds 40°C (feeling hot), check the cause
Every half year	Voltage detection	<ul style="list-style-type: none"> ● At the end of charging, measure and record the busbar voltage and the positive and negative terminal voltages of the battery pack. The voltages of the two are consistent. Otherwise, check whether the cable at the corresponding connection is faulty. ● In the first year, real-time data collection at the end of discharge was performed at least every six months. ● Beginning in the second year, on-site capacity determination will be conducted every three months. If a certain battery cell is frequently overcharged and over-discharged in the historical alarm information viewed through the RS232 interface, it means that the battery cell has touched the charging protection point and the discharging protection point for a long time. This situation may lead to insufficient backup time, it is recommended to replace it in time

The final state of charge and discharge can be judged by the capacity light, refer to the definition of LED light capacity status light.

10. Packing List

See below for packing list

NO.	Material name	Specification/Module	Number
1	48100Ah lithium iron phosphate battery	48100	1 set/box
2	Positive and negative output lines	25mm ² flame retardant cable, length 0.5m, crimp 25-6 copper noses at both ends, one red and one black.	1 set/1 module
3	RS485 cascade communication line	0.5 meters long, with RJ45 crystal heads at both ends.	1root/1 modules
4	RS232 USB	1.5 meters long, one end is the corresponding crystal head, and the other end is the USB interface.	optional
5	Product manual	/	1
6	Certificate	/	1
7	Hanging ear screw	M6*16(stud 16mm)	4
8	Dry contact terminal	Matching according to the number of dry nodes of the BMS	1

11.Storage, maintenance and transportation

11.1. Storage

1. The battery pack is usually stored at a state of charge of 20% to 40% in a clean, dry, ventilated and rain-proof room with an ambient temperature of -5°C to 35°C and a relative humidity of not more than 75%, and should be placed flat. Pad height, not less than 100MM from the ground;
2. Batteries cannot be stored with active chemicals or dusting items;
3. The battery cannot be subjected to any mechanical shock or heavy pressure;
4. The battery should avoid direct sunlight, keep away from the fire source, and the distance from the heat source should not be less than 2M;
5. From the date of manufacture, every 3 months of storage should be charged with a current of $0.2\sim 0.5\text{C}$ for 30~60min, and the temperature range is $25^{\circ}\text{C}\pm 5^{\circ}\text{C}$.

11.2. Transportation

The battery pack should be packaged and shipped. During transportation, avoid severe vibration, shock or extrusion, and avoid sun and rain. Batteries can be transported by vehicles such as cars, trains, ships, and planes.

12. Maintain

The battery pack should remain at 40% - 60% of state of charge;

When the battery is not in use for a long time, it is recommended to charge it with 0.2c current every three months or so.

During the maintenance process, do not install or remove the battery in the battery pack by yourself, otherwise the battery performance will be reduced;

Any battery in the battery pack shall not be disassembled or replaced without authorization, and dissection of the battery is strictly prohibited.

13.Battery usage precautions

Please read the instruction manual and precautions carefully before use. When used correctly according to the product characteristics, the battery will be a safe, reliable and convenient storage battery.

Warn! Improper use of lithium-ion batteries can result in personal injury or fire!

1. When charging the battery, pay attention to ensure that the polarity is correct, and do not reverse the charging of the battery;
2. Do not expose the battery to adverse environments, such as extreme temperatures, deep cycling, frequent overcharge/overdischarge;
3. If you find that the battery is abnormal, please stop using it immediately and report it to a professional for treatment;
4. Ensure that batteries and battery management systems are kept away from dangerous goods or dangerous materials;
5. It is forbidden to short-circuit the battery;
6. It is forbidden to burn or destroy the battery, which may cause the release or burning of harmful gases;
7. Do not disassemble, squeeze, pierce or burn.
8. Rain is prohibited;
9. It is forbidden to be directly exposed to sunlight;
10. Prohibit exposure to temperatures above 60°C;
11. It is forbidden to discard the battery in the garbage;
12. It is forbidden to use other types of batteries in series or in parallel with lithium-ion batteries;
13. It is forbidden to use new and old batteries (groups) in series or in parallel.

14. Product Liability

Consumers must strictly abide by the requirements of this product specification to use this product. Misuse may lead to serious accidents. The company is not responsible for any accidents caused by the operation and use that are not strictly in accordance with this product specification. The company reserves the right to change the contents of this specification without prior notice; the final interpretation right of this information belongs to the company.