

Battery system home storage series

User Manual



Product Name:48V100Ah Lithium Battery

Product Model:SG48100P

Product Specifications:51.2V 100Ah

Catalogue

1. Document description	2
2. Definition of Terms	2
3. Battery system performance parameters	2
4. Outline and Structural Dimensions of Battery System	4
5. Definition of battery system interface	5
6. Functional block diagram.....	7
7. Battery Management System Specifications.....	8
7.1.Basic parameter settings.....	8
7.2.Interface	12
7.3.Communication description	14
8. Product function and performance description	15
8.1.Charging performance.....	15
8.2.Discharge curve at different magnification.....	15
9. Using & Maintenance Suggestions	16
9.1.LED indication description	16
9.2. Buzzer action description.....	17
9.3. Key Description	17
9.4.Sleep and wake up.....	18
9.5.DIP switch settings.....	19
9.6.The routine maintenance of the battery part can be carried out by referring to the table ...	21
9.7.Battery pack communication parallel wiring	22
9.8 .Battery pack power cable wiring	22
9.9.LCD Display Detailed Explanation	24
10. Packing List.....	25
See below for packing list.....	25
11. Storage, maintenance and transportation	25
11.1.Storage	25
11.2. Transportation	26
12. Maintain	26
13. Battery usage precautions.....	26
14. Product Liability.....	27

1.Document description

This specification covers the performance indexes, technical requirements and safety issue of the 48V100Ah.

2.Definition of Terms

BMS	Battery Management System
DOD	Depth Of Discharge
EOL	End Of Life
OCV	Open Circuit Voltage
SOC	State Of Charge
SOH	State Of Health
EMC	Electro Magnetic Compatibility
Nominal voltage	Appropriate voltage approximation to identify or identify a cell or an electrochemical system.
Capacity	(The amount of power a battery can provide when fully charged under specified conditions. Usually expressed in Ah.)
Energy	The energy that can be provided by a fully charged battery under specified conditions. Usually expressed in Wh or kWh.
Unit	“V” (Volt) (Voltage unit) “A” (Ampere) (Current unit) “Ah” (Ampere-Hour) (unit of charge) “Wh” (Watt-Hour) (electrical energy unit) “Ω” (Ohm) (resistance unit) “°C” (degree Celsius) (temperature unit) “mm” (millimetre) (length unit) “s” (second) (Time unit) “kg” (kilogram) (Weight unit) “Hz” (Hertz) (Frequency unit)

3.Battery system performance parameters

No.	Item	Technical parameter	Note
1	Battery Type	Lithium iron phosphate battery	/
2	Rated capacity	100Ah	@25°C±2, 0.2C, 100%DOD

3	Nominal voltage	51.2V	
4	Recommended charging voltage	54.5V	
5	Charging Limited Voltage	57.6V	
6	SOC working range	0~100%	Recommended range of use: 20%~95%
7	Standard discharge current	50A	
8	Maximum continuous discharge current	100A	
9	Standard charging current	50A	
10	Maximum continuous charge current	100A	
11	Maximum cut-off voltage for charging	57.6V	
12	Charge cut-off current	5A	0.05C magnification
13	Discharge cut-off voltage	43.2V	
14	PACK cycle life	≥ 7000	80%DOD 25°C±2°C, 0.5C charge/0.5C discharge
15	Thermal management method	Natural heat dissipation	
16	IP protection class	IP31 battery box	
17	Flammability rating	plastic parts UL94 V-0	
18	Total system mass	Around 43KG	
19	Battery system shell material	BLACK Q235A	Color can be customized
20	Shipping SOC	SOC45-55%	
21	Dimension (L*W*H mm)	☑442*460*133 (3U) ±1mm	
22	Design life	15 Year	
23	Parallel function	Supports up to 63 batteries in parallel	
24	Display function	English smart display	
25	Charging current limit function	Current limit 20A	Charging current limit can be set according to customer requirements
26	Communication mode	☑RS232	Communication mode can be set according to customer requirements
		☑RS485	
		☑CAN	
27	communication protocol	Support multiple protocols	Communication protocol can be set according to customer requirements
28	Storage ambient temperature	-10~+45°C	Recommended storage temperature: 0~+30°C
29	Working temperature	Battery charging: 0~ 45°C Battery discharging:-20~ +60°C	
30	Relative humidity of working environment	≤ 95	Best Use Relative Humidity: ≤85%

4. Outline and Structural Dimensions of Battery System

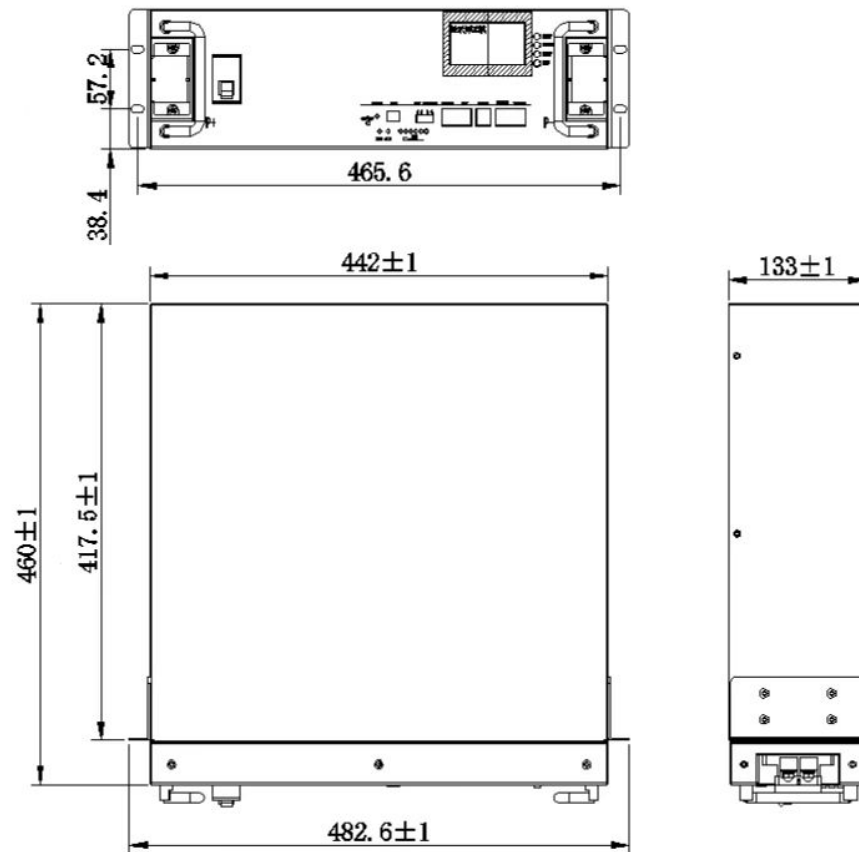

5. Definition of battery system interface

5.1. Panel Schematic

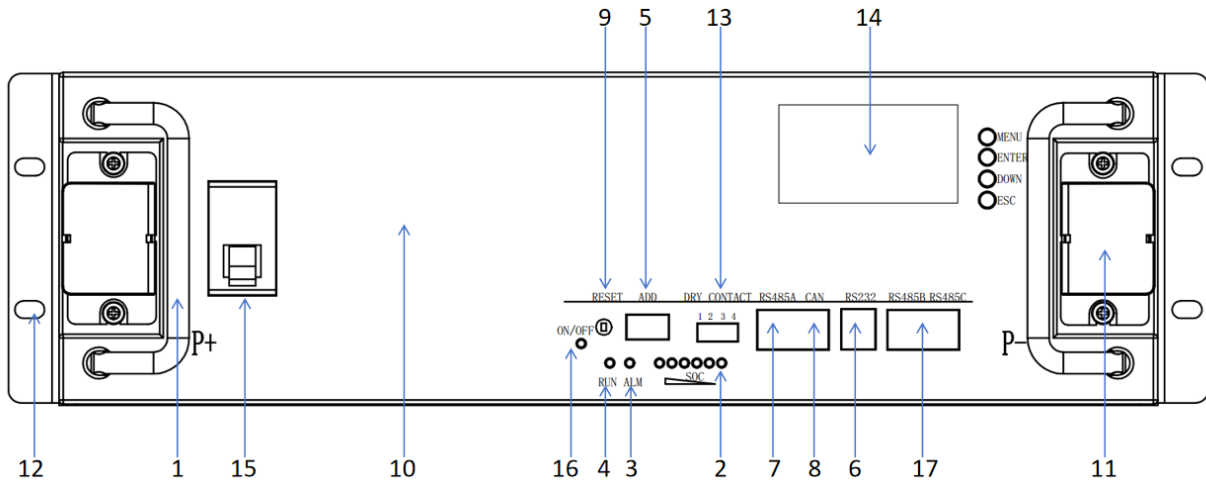

5.2. Module Panel Description

NO	Function definition	Function Description	Note
1	Handle	Carrying handle	
2	SOC	Capacity status light	Six green LED lights to show the current charge of the lithium battery pack
3	ALM	Alert	Red LED light, normally off under normal conditions, always on under fault conditions, and a voice prompt
4	RUN	Run	Green light, always on when the product is running
5	ADD	DIP switch	Use 6 bit binary DIP switch to set address allocation when products are used in parallel
6	RS232	RS232 communication	Uplink communication port, RS232 communication mode when uploading data, data content includes system parameters, system status and alarm information. The rate of 9600bps is generally used. Note: Wiring definitions are implemented in accordance with BMS product specifications
7	RS485	RS485 communication	RS485 communication method
8	CAN	CAN communic	CANcommunication method
9	RESET	Reset	When the product is in an abnormal state or in a hibernation state, the product can be restarted and woken up through the reset button to ensure the stable operation of the system
10	Main panel	Shell	Sheet metal thickness 1.5mm, galvanized frosted paint, color: black

11	Terminals	Input and output terminals	Battery positive and negative output terminals
12	Hanging ears	Mounting ears	The spacing is implemented according to the national standard
13	dry contact terminal	Load output port	<p>example: definition:</p> <p>Dry contact 1-PIN1 to PIN2: normally open, closed during fault protection</p> <p>Dry contacts 2-PIN3 to PIN4: normally open, SOC<5%, closed for low battery alarm.</p>
14	Display	Display screen	Battery information can be viewed on the display
15	Air breaker	Breaker	For controlling battery output
16	ON/OFF	ON/OFF	Battery switch status indicator
17	Parallel dual RS485	RS485B RS485C	For battery parallel RS485 communication

6. Functional block diagram

The functional block diagram is shown in the figure below

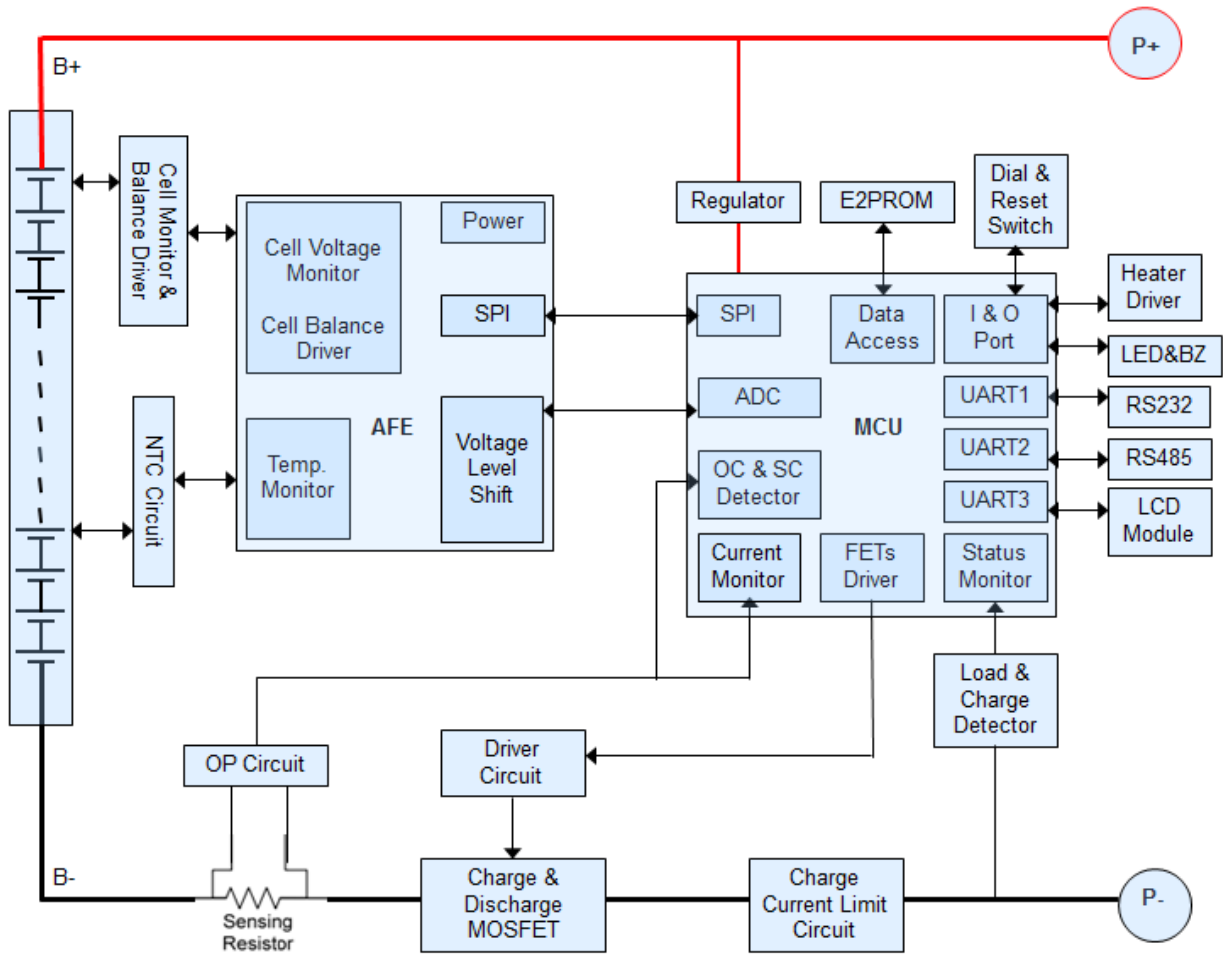

7.Battery Management System Specifications

7.1.Basic parameter settings

NO.	Indicator item		Factory default parameters	Is it possible to set	Note
1	Cell overcharge protection	Cell overcharge alarm voltage	3600mV	Can be set	
		Cell overcharge protection voltage	3700mV	Can be set	
		Cell overcharge protection delay	4.0S	Can be set	
	Single Over voltage Protection Released	overcharge protection release voltage Cell	3380mV	Can be set	
		Capacity release	SOC < 96%	Can be set	
		Discharge release	discharge current > 2A		
2	Cell over discharge protection	Cell over-discharge alarm voltage	2700mV	Can be set	After 30 seconds of over-discharge protection, if it still cannot recover, it will enter low power consumption mode
		Cell over-discharge protection voltage	2500mV	Can be set	
		Monomer over-discharge protection delay	1.0S	Can be set	
	Cell over-discharge protection released	Cell over-discharge protection release voltage	2800mV	Can be set	
		(Release when charging)	Plug into the charger to activate		
3	Overall overcharge protection	Overall overcharge warning voltage	57.6V	Can be set	
		Overall overcharge protection voltage	58.4V	Can be set	
		Overall overcharge protection delay	1.0S	Can be set	
	Overall overvoltage protection released	Overall overcharge protection release voltage	54.1V	Can be set	
		Capacity release	SOC < 96%	Can be set	
		Discharge release	discharge current > 2A		
4		Overall over-discharge warning voltage	43.2V	Can be set	After 30 seconds of over-discharge

	Overall over discharge protection	Overall over-discharge protection voltage	40V	Can be set	protection, if it still cannot recover, it will enter low power consumption mode
		Overall over-discharge protection delay	1.0S	Can be set	
	Overall over-discharge protection released	Overall over-discharge protection release voltage	44.8V	Can be set	
		Release when charging	Plug into the charger to activate		
5	Charging current limit function	Charging current limit	20A		
6	Charge over current protection	Charge over current alarm current	105A	Can be set	Appearing 10 times in a row will lock the status and will no longer automatically release
		Charge over current protection current	110A	Can be set	
		Charge over current protection delay	1.0S	Can be set	
	Charging over current protection released	Automatic release	Automatically cancel after 1min		
Discharge release		Discharge current > 1A			
7	Discharge over current 1 protection	Discharge over current 1 alarm current)	105A	Can be set	Appearing 10 times in a row will lock the status and will no longer automatically release
		Discharge over current 1 protection current)	110A	Can be set	
		Discharge over current 1 protection delay	1.0S	Can be set	
	Discharge over current 1 protection released	Automatic release	Automatically cancel after 1min		
		Charge release	Charge current > 1A		
8		Discharge over current 2 protection current	≥150A	Can be set	Appearing 10 times in a row will lock

	Discharge over current 2	Discharge over current 2 protection delay	500mS	Can be set	the status and will no longer automatically release
	Discharge over current 2 protection released	Automatic release	Automatically cancel after 1min		
		charge release	Charge current > 1A		
9	Short circuit protection	Short circuit protection function		(Have)	
		Short circuit protection released	When there is charging, the short circuit protection is released		
			After the load is removed, it will automatically disarm		
10	MOS high temperature protection	MOS over temperature alarm temperature)		90°C	Can be set
		MOS over temperature protection temperature)		115°C	Can be set
		MOS protection release temperature)		85°C	Can be set
11	Cell temperature protection	Charging low temperature warning temperature)		0°C	Can be set
		Charging low temperature protection temperature)		-5°C	Can be set
		Charging low temperature protection release temperature		0°C	Can be set
		Charging high temperature alarm temperature	55°C		Can be set
		Charging high temperature protection temperature)	60°C		Can be set
		Charging high temperature protection release temperature	50°C		Can be set
		Discharge low temperature alarm temperature	-15°C		Can be set
Discharge low temperature protection temperature	-20°C		Can be set		
(Discharge low temperature protection release temperature	-15°C		Can be set		

		Discharge high temperature alarm temperature	60°C	Can be set	
		Discharge high temperature protection temperature	65°C	Can be set	
		Discharge high temperature protection release temperature	55°C	Can be set	
12	Ambient temperature alarm	Ambient low temperature alarm temperature	-15°C	Can be set	
		Ambient low temperature protection temperature	-20°C	Can be set	
		Ambient cryogenic protection release temperature	-15°C	Can be set	
		Ambient high temperature alarm temperature	65°C	Can be set	
		Ambient high temperature protection temperature	75°C	Can be set	
		Ambient high temperature protection release temperature	65°C	Can be set	
13	Current consumption	Self-consumption current during operation	≤55mA (with display)		
			≤45mA(without display)		
		Low power mode current	≤200μA		
14	Equalization function	Equalization turn-on voltage	3500mV	Can be set	
		Open differential pressure	30mV	Can be set	
15	Capacity default settings	Low battery warning	SOC<5%	Can be set	(No alarm when charging)
		Full capacity setting	100AH	Can be set	
16	Sleep function	Sleep voltage	3150mV	Can be set	
		Delay	5min	Can be set	
		Over pressure recovery	500mV		
17	Cell failure protection	Monomer differential pressure	Voltage difference>1V		Charge and discharge are not allowed
18	Full charge judgment	Full charge voltage	56V	Can be set	After simultaneously satisfying, Stop
		Cut off current	5A	Can be set	

					charging and update SOC to 100%
--	--	--	--	--	---------------------------------

7.2.Interface

7.2.1.Interface diagram

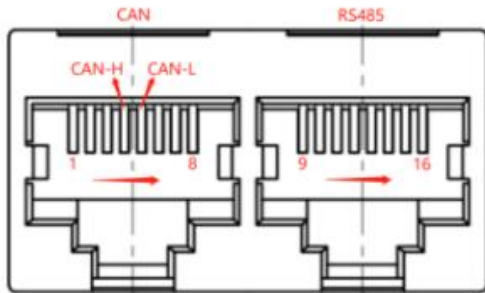

CAN and RS485 interface



1 2 3 4

dry contact

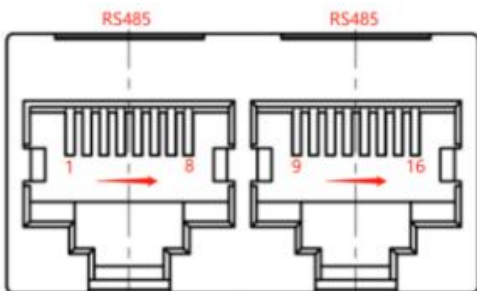

Parallel communication port

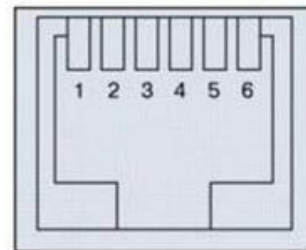

RS232 communication interface

7.2.2. Interface Definition

RS232--Using 6P6C vertical RJ11 socket	
RJ11	Definition description
2	NC
3	TX
4	RX
5	GND

RS485 and CAN interface

RS485--Using 8P8C vertical RJ45 socket		CAN--Using 8P8C vertical RJ45 socket	
RJ45 Pin	Definition description	RJ45 Pin	Definition description
9、16	RS485-B1	1、3、6、7、8	NC
10、15	RS485-A1	4	CAN-H
11、14	GND	5	CAN-L
12、13	NC	2	GND

Parallel communication port

RS485--Using 8P8C vertical RJ45 socket		RS485--Using 8P8C vertical RJ45 socket	
RJ45Pin	Definition description	RJ45 Pin	Definition description
1、8	RS485-B	9、16	RS485-B
2、7	RS485-A	10、15	RS485-A
3、6	GND	11、14	GND
4、5	NC	12、13	NC

7.3.Communication description

7.3.1. RS232 communication

The BMS can communicate with the host computer through the RS232 interface, so as to monitor various information of the battery on the host computer side, including battery voltage, current, temperature, status, SOC, SOH and battery production information, etc. The default baud rate is 9600bps.

7.3.2.RS485 communication

With dual RS485 interface, you can view the information of PACK, the default baud rate is 9600bps. To communicate with the monitoring device through RS485, the monitoring device is used as the host to poll data according to the address, and the address setting range is 2~63

7.3.3. CAN communication

CAN communication, baud rate 500K.

8.Product function and performance description

8.1.Charging performance

- ◆ Standard charging current (25°C)
- ◆ Standard charging voltage: 57.6V
- ◆ Standard charging mode and charging curve:

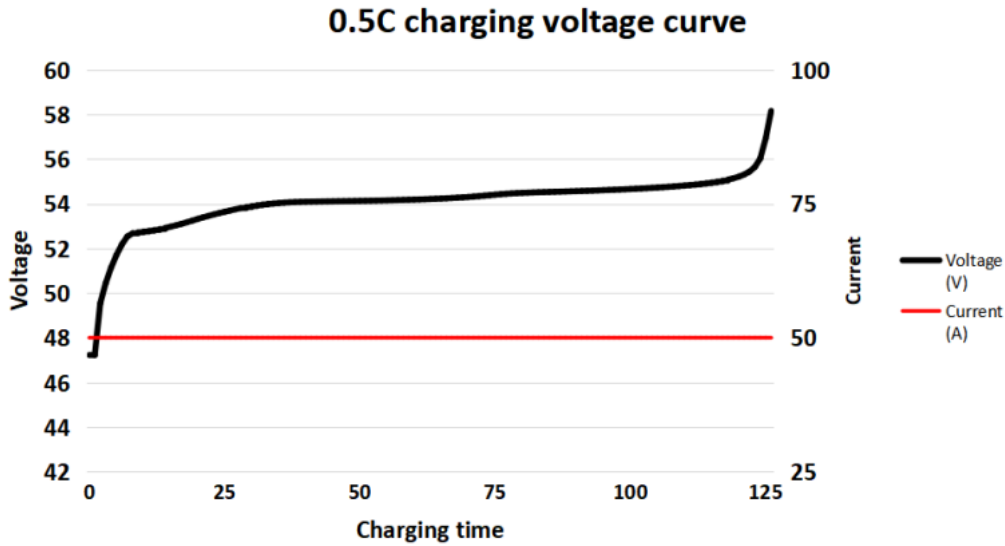

8.2.Discharge curve at different magnification

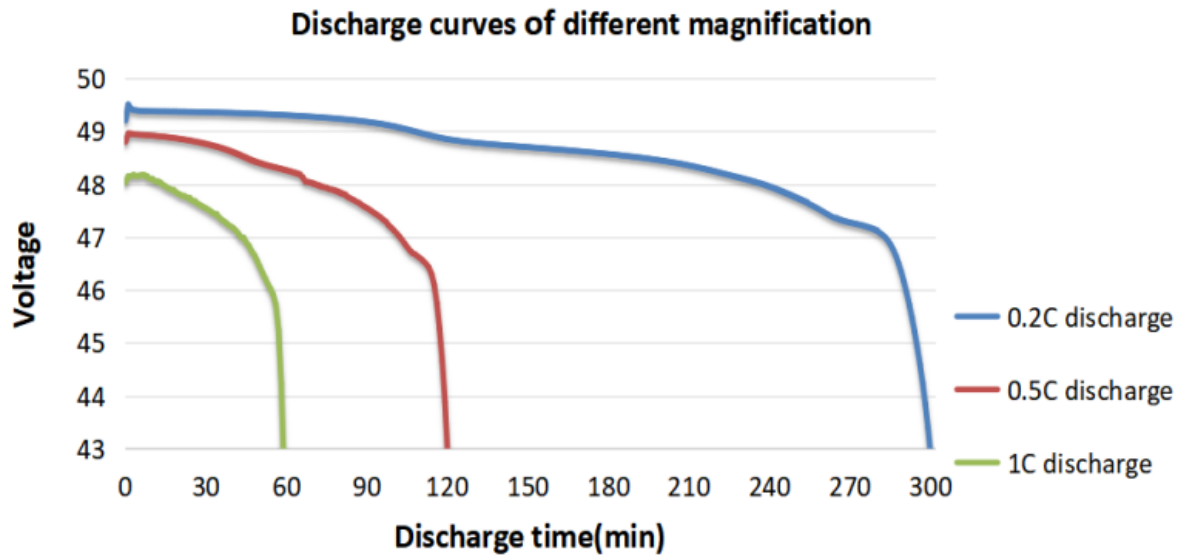

9.Using & Maintenance Suggestions

9.1.LED indication description

Table 1 LED working status indication

Condition		Charging						Discharging					
Capacity indicator		L6●	L5●	L4●	L3●	L2●	L1●	L6●	L5●	L4●	L3●	L2●	L1●
Electricity (%)	0 ~ 17%	black	black	black	black	black	flash2	black	black	black	black	black	Always bright
	17 ~ 33%	black	black	black	black	flash 2	Always bright	black	black	black	black	Always bright	Always bright
	33 ~ 50%	black	black	black	flash 2	Always bright	Always bright	black	black	black	Always bright	Always bright	Always bright
	50 ~ 66%	black	black	flash 2	Always bright	Always bright	Always bright	black	black	Always bright	Always bright	Always bright	Always bright
	66-83%	black	flash 2	Always bright	Always bright	Always bright	Always bright	black	Always bright	Always bright	Always bright	Always bright	Always bright
	83-100%	flash 2	Always bright	Always bright	Always bright	Always bright	Always bright	Always bright	Always bright	Always bright	Always bright	Always bright	Always bright
Running lights●		Always bright						flash3					

Table 2 Description of capacity indication

Condition	Normal/Alarm/Protect	RUN ●	ALM ●	LED						Illustrate
				Battery indicator LED						
				●	●	●	●	●	●	
Shutdown	Hibernate	black	black	black	black	black	black	black	black	Annihilate
Standby	Normal	flash1	black	According to the battery indicator						Standby mode
	Alarm	flash1)	flash3							Module low voltage
Charging	Normal	Always bright)	black	According to the battery indicator (battery indication maximum LED flashes 2)						(The highest power LED flashes (flashing 2), the overcharge alarm ALM does not flash)
	Alarm	Always bright	3 flash3							
	Overcharge protection	Always bright	black	Always bright	Always bright	Always bright	Always bright	Always bright	Always bright	(If there is no utility power, the indicator light is in standby state)
	Temperature, overcurrent, fail safe	black	Always bright	black	black	black	black	black	black	black
Discharging	Normal	flash3	black	(According to the battery indicator)						
	Alarm	flash3)	flash3							
	Undervoltage protection	black	black	black	black	black	black	black	black	black

	Temperature, overcurrent, short circuit, reverse connection, fail safe	black	Always bright	black	black	black	black	black	black	Stop discharge
Invalid		black	Always bright	black	black	black	black	black	black	Stop charging and discharging

Table 3 LED flashing description

Flashing method	Bright	Black
flash 1	0.25S	3.75S
flash 2	0.5S	0.5S
flash 3	0.5S	1.5S

Note:

The LED indicator alarm can be enabled or disabled through the host computer, and the factory default is enabled.

9.2. Buzzer action description

- 1) In case of failure, it will beep for 0.25S every 1S;
- 2) During protection, it will beep for 0.25S every 2S (except for overvoltage protection);
- 3) When alarming, it will beep every 3S for 0.25S (except overvoltage alarm);
- 4) The buzzer function can be enabled or disabled by the host computer, and the factory default is disabled.

9.3. Key Description

- 1) When the BMS is in the dormant state, press the button (3~6S) and release it, the protection board will be activated, and the LED indicators will light up in sequence from "RUN" for 0.5 seconds.
- 2) When the BMS is activated, press the button (3~6S) and release it, the protection board is put to sleep, and the LED indicators light up sequentially for 0.5 seconds from the lowest battery light.
- 3) When the BMS is activated, press the button (6~10S) and release it, the protection board will be reset, and all the LED lights will light up at the same time for 1.5 seconds.

After the BMS is reset, it still retains the parameters and functions set by the host computer. If it is necessary to restore the initial parameters, it can be achieved through the "restore default value" of the host computer, but the relevant operation records and stored data remain unchanged (such as power, cycle times, etc.), protection records, etc.).

9.4.Sleep and wake up

9.4.1. Hibernate

When any of the following conditions are met, the system enters a low-power mode:

- ◆ The single or overall over-discharge protection has not been released within 30 seconds.
- ◆ Release the button after pressing the button for 3 seconds.
- ◆ The minimum cell voltage is lower than the sleep voltage, and the duration reaches the sleep delay time (at the same time, no communication, no protection, no balance, and no current are satisfied).
- ◆ The standby time is more than 24 hours (no communication, no charging and discharging, no mains power).
- ◆ Forced shutdown through the host computer software.

Before entering the sleep mode, make sure that the input terminal is not connected to an external voltage, otherwise it will not be able to enter the low power consumption mode.

9.4.2. wake

When the system is in low-power mode and meets any of the following conditions, the system will exit the low-power mode and enter the normal operation mode:

- ◆ Connect the charger, the output voltage of the charger must be greater than 48V.
- ◆ Press the button for 3S and release the button.
- ◆ Connect to the communication line and open the software of the upper computer (it enters the sleep state due to over-discharge protection, this method cannot wake up the protection board).

Remarks:

- ◆ After the single or overall over-discharge protection, it enters the low-power mode, wakes up regularly every 4 hours, and turns on the charge and discharge MOS. If it can be charged, it will exit the dormant state and enter normal charging; if it cannot be charged after 10 consecutive automatic wake-ups, it will no longer automatically wake up.
- ◆ When the system is defined as the end of charging, the recovery voltage is not reached after 2 days of standby (standby time setting value), and the charging is forced to resume until the end of charging again.

9.5.DIP switch settings

When the battery packs are used in parallel, different PACK can be distinguished by their hardware addresses, and the hardware address of each PACK in the entire battery stack is unique. The hardware addresses can be set in sequence through the DIP switches on the board. Refer to the following for the definition of the switches. surface.

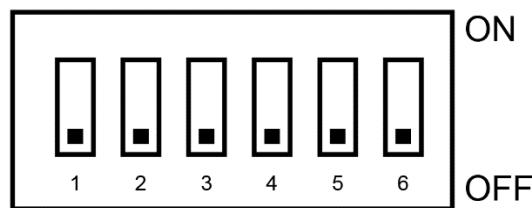

ADD	Dip switch position					
	#1	#2	#3	#4	#5	#6
1	ON	OFF	OFF	OFF	OFF	OFF
2	OFF	ON	OFF	OFF	OFF	OFF
3	ON	ON	OFF	OFF	OFF	OFF
4	OFF	OFF	ON	OFF	OFF	OFF
5	ON	OFF	ON	OFF	OFF	OFF
6	OFF	ON	ON	OFF	OFF	OFF
7	ON	ON	ON	OFF	OFF	OFF
8	OFF	OFF	OFF	ON	OFF	OFF
9	ON	OFF	OFF	ON	OFF	OFF
10	OFF	ON	OFF	ON	OFF	OFF
11	ON	ON	OFF	ON	OFF	OFF
12	OFF	OFF	ON	ON	OFF	OFF
13	ON	OFF	ON	ON	OFF	OFF
14	OFF	ON	ON	ON	OFF	OFF
15	ON	ON	ON	ON	OFF	OFF
16	OFF	OFF	OFF	OFF	ON	OFF

17	ON	OFF	OFF	OFF	ON	OFF
18	OFF	ON	OFF	OFF	ON	OFF
19	ON	ON	OFF	OFF	ON	OFF
20	OFF	OFF	ON	OFF	ON	OFF
21	ON	OFF	ON	OFF	ON	OFF
22	OFF	ON	ON	OFF	ON	OFF
23	ON	ON	ON	OFF	ON	OFF
24	OFF	OFF	OFF	ON	ON	OFF
25	ON	OFF	OFF	ON	ON	OFF
26	OFF	ON	OFF	ON	ON	OFF
27	ON	ON	OFF	ON	ON	OFF
28	OFF	OFF	ON	ON	ON	OFF
29	ON	OFF	ON	ON	ON	OFF
30	OFF	ON	ON	ON	ON	OFF
31	ON	ON	ON	ON	ON	OFF
32	OFF	OFF	OFF	OFF	OFF	ON
33	ON	OFF	OFF	OFF	OFF	ON
34	OFF	ON	OFF	OFF	OFF	ON
35	ON	ON	OFF	OFF	OFF	ON
36	OFF	OFF	ON	OFF	OFF	ON
37	ON	OFF	ON	OFF	OFF	ON
38	OFF	ON	ON	OFF	OFF	ON
39	ON	ON	ON	OFF	OFF	ON
40	OFF	OFF	OFF	ON	OFF	ON
41	ON	OFF	OFF	ON	OFF	ON
42	OFF	ON	OFF	ON	OFF	ON
43	ON	ON	OFF	ON	OFF	ON
44	OFF	OFF	ON	ON	OFF	ON
45	ON	OFF	ON	ON	OFF	ON
46	OFF	ON	ON	ON	OFF	ON
47	ON	ON	ON	ON	OFF	ON
48	OFF	OFF	OFF	OFF	ON	ON
49	ON	OFF	OFF	OFF	ON	ON
50	OFF	ON	OFF	OFF	ON	ON
51	ON	ON	OFF	OFF	ON	ON
52	OFF	OFF	ON	OFF	ON	ON
53	ON	OFF	ON	OFF	ON	ON
54	OFF	ON	ON	OFF	ON	ON
55	ON	ON	ON	OFF	ON	ON
56	OFF	OFF	OFF	ON	ON	ON
57	ON	OFF	OFF	ON	ON	ON
58	OFF	ON	OFF	ON	ON	ON
59	ON	ON	OFF	ON	ON	ON
60	OFF	OFF	ON	ON	ON	ON
61	ON	OFF	ON	ON	ON	ON
62	OFF	ON	ON	ON	ON	ON
63	ON	ON	ON	ON	ON	ON

9.6. The routine maintenance of the battery part can be carried out by referring to the table

Period	Item	Treatment measures
Per month	(Operating environment)	Keep away from heat sources and avoid direct sunlight
	Visual inspection	If the appearance is damaged, leaked or deformed, the faulty battery pack should be disconnected, photographed and replaced.
Each quarter	Clean appearance	Clean the exterior with a cotton cloth. Due to the high voltage of the battery pack, care should be taken when cleaning.
	Connection Status	<ul style="list-style-type: none"> ● Check the bolts at each terminal and retighten them if they are loose. ● If the temperature of the connection line exceeds 40°C (feeling hot), check the cause
Every half year	Voltage detection	<ul style="list-style-type: none"> ● At the end of charging, measure and record the busbar voltage and the positive and negative terminal voltages of the battery pack. The voltages of the two are consistent. Otherwise, check whether the cable at the corresponding connection is faulty. ● In the first year, real-time data collection at the end of discharge was performed at least every six months. ● Beginning in the second year, on-site capacity determination will be conducted every three months. If a certain battery cell is frequently overcharged and over-discharged in the historical alarm information viewed through the RS232 interface, it means that the battery cell has touched the charging protection point and the discharging protection point for a long time. This situation may lead to insufficient backup time, it is recommended to replace it in time

The final state of charge and discharge can be judged by the capacity light, refer to the definition of LED light capacity status light.

9.7. Battery pack communication parallel wiring

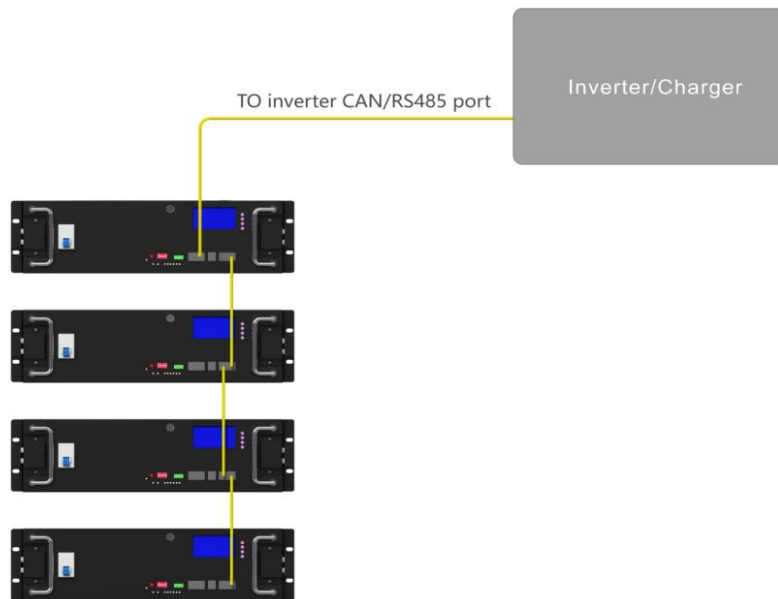

9.8 .Battery pack power cable wiring

Please note:

1. Batteries cannot be used in series.
2. When connecting in parallel, it is necessary to pay attention to the SOC, the SOC must be consistent before connecting in parallel.
3. Please turn off the inverter and turn off the battery before connecting the battery system in parallel, and then turn on the battery and inverter again after capacity expansion.
4. The connecting cables between battery and battery should be the same length, and the connecting cables between battery and inverters should be the same length.
5. The wire gauge of the connecting cable between batteries and the cable between battery and inverter is related to the volume of charging current and discharging current and the wiring connection method, etc., so it can not be standardized, If there are any questions, please consult the supplier.
6. It is recommended to have the system installed by a qualified professional.

Suggested option 1 (example:4 batteries) :

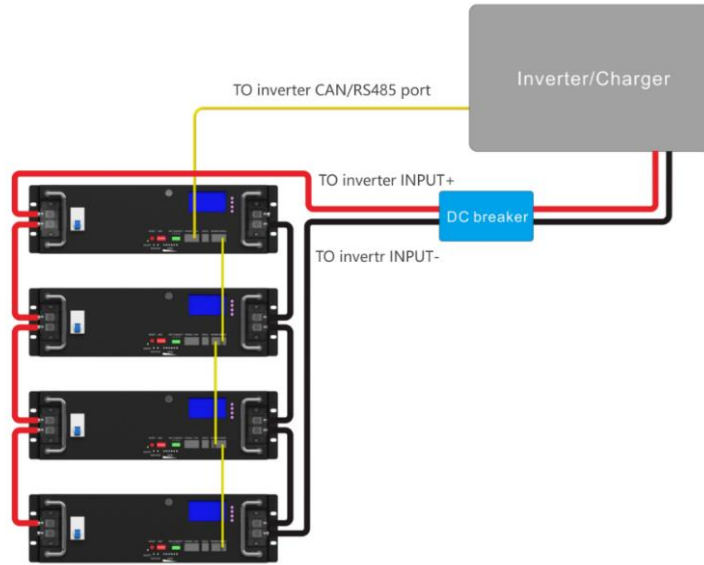

Suggested option 2 (example:4 batteries) :

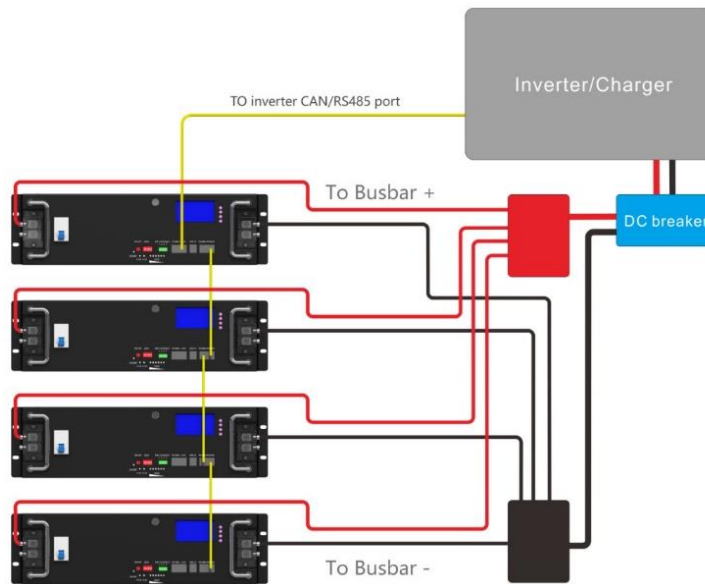

Wiring diggram not allowed:

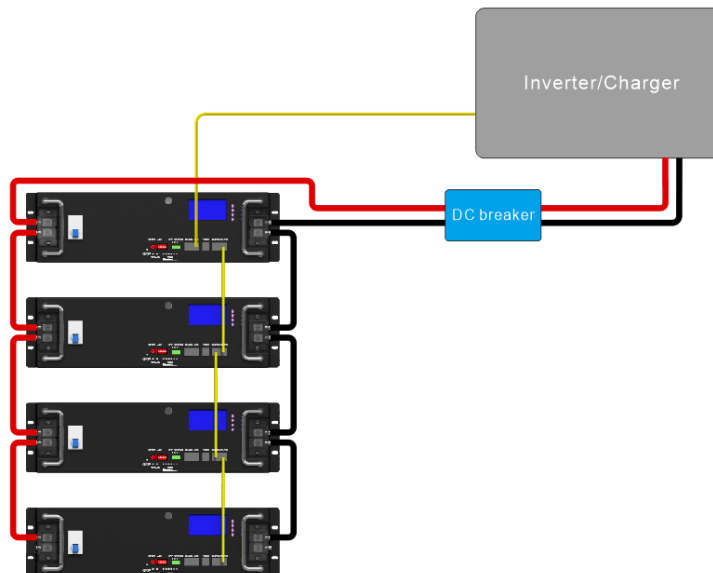

9.9.LCD Display Detailed Explanation

Menu						
First level column		Secondary Column		Level three column		
Name	Meaning	Name	Meaning	Name	Meaning	
Analog Info	Analog Info	PackV	Pack Voltage			
		Im	Current			
		Temperature	Temperature	T1	Temperature T1	
				T2	Temperature T2	
				T3	Temperature T3	
				T4	Temperature T4	
				PCB_T	MOS Temperature	
				ENV_T	Environment Temperature	
		Cell Voltage	Cell Voltage	Cell01:	Cell Voltage 01:	
				Cell02:	Cell Voltage 02:	
				
				Cell15:	Cell Voltage 15:	
				Cell16:	Cell Voltage 16:	
		CellCapacity	CellCapacity	SOC	State Of Charge	
				FCC	Full Charge Capacity	
				Rm	Remain Capacity	
CC	Cycle Count					
BMS Status	BMS Status	Status	BMS Status			
		Record	Fault Record	SCP	Short Circuit Protection	
				O/UTP	Over / Under Temperature Protection	
				OCP	Over Current Protection	
				UVP	Under Voltage Protection	
				OVP	Over Voltage Protection	
		BMS Status	BMS Status	OT	Over Temperature Warning	
				OTP	Over Temperature Protection	
				OV	Over Voltage Warning	
				OVP	Over Voltage Protection	
				UV	Under Voltage Warning	
				UVP	Under Voltage Protection	
				OC	Over Current Warning	
				OCP	Over Current Protection	
SCP	Short Circuit Protection					
Failure	Failure					
Para Setting	Para Setting	Non-Production manufacturer can not use				
Sys Setting	Sys Setting	Baud rate	Baud rate			

10.Packing List

See below for packing list

NO.	Material name	Specification/Module	Number
1	48100Ah lithium iron phosphate battery	48100	1 set/box
2	Positive and negative output lines	25mm ² flame retardant cable, length 0.5m, crimp 25-8 copper noses at both ends, one red and one black.	1 set/1 module
3	RS485 cascade communication line	0.5 meters long, with RJ45 crystal heads at both ends.	1root/1 modules
4	RS232 USB	1.2 meters long, one end is the corresponding crystal head, and the other end is the USB interface.	optional
5	Product manual	/	1
6	Certificate	/	1
7	Hanging ear screw	M6*16(stud 16mm)	4
8	Dry contact terminal	Matching according to the number of dry nodes of the BMS	1

11.Storage, maintenance and transportation

11.1.Storage

- ◆ The battery pack is usually stored at a state of charge of 20% to 40% in a clean, dry, ventilated and rain-proof room with an ambient temperature of -5°C to 35°C and a relative humidity of not more than 75%, and should be placed flat. Pad height, not less than 100MM from the ground;
- ◆ Batteries cannot be stored with active chemicals or dusting items;
- ◆ The battery cannot be subjected to any mechanical shock or heavy pressure;
- ◆ The battery should avoid direct sunlight, keep away from the fire source, and the distance from the heat source should not be less than 2M;
- ◆ From the date of manufacture, every 3 months of storage should be charged with a current of 0.2~0.5C for 30~60min, and the temperature range is 25°C±5°C.5) .

11.2. Transportation

The battery pack should be packaged and shipped. During transportation, avoid severe vibration, shock or extrusion, and avoid sun and rain. Batteries can be transported by vehicles such as cars, trains, ships, and planes.

12. Maintain

The battery pack should remain at 40% - 60% of state of charge;

When the battery is not in use for a long time, it is recommended to charge it with 0.2c current every three months or so.

During the maintenance process, do not install or remove the battery in the battery pack by yourself, otherwise the battery performance will be reduced;

Any battery in the battery pack shall not be disassembled or replaced without authorization, and dissection of the battery is strictly prohibited.

13. Battery usage precautions

Please read the instruction manual and precautions carefully before use. When used correctly according to the product characteristics, the battery will be a safe, reliable and convenient storage battery.

Warn! Improper use of lithium-ion batteries can result in personal injury or fire!

1. When charging the battery, pay attention to ensure that the polarity is correct, and do not reverse the charging of the battery;
2. Do not expose the battery to adverse environments, such as extreme temperatures, deep cycling, frequent overcharge/overdischarge;
3. If you find that the battery is abnormal, please stop using it immediately and report it to a

- professional for treatment;
4. Ensure that batteries and battery management systems are kept away from dangerous goods or dangerous materials;
 5. It is forbidden to short-circuit the battery;
 6. It is forbidden to burn or destroy the battery, which may cause the release or burning of harmful gases;
 7. Do not disassemble, squeeze, pierce or burn.
 8. Rain is prohibited;
 9. It is forbidden to be directly exposed to sunlight;
 10. Prohibit exposure to temperatures above 60°C;
 11. It is forbidden to discard the battery in the garbage;
 12. It is forbidden to use other types of batteries in series or in parallel with lithium-ion batteries;
 13. It is forbidden to use new and old batteries (groups) in series or in parallel.

14. Product Liability

Consumers must strictly abide by the requirements of this product specification to use this product. Misuse may lead to serious accidents. The company is not responsible for any accidents caused by the operation and use that are not strictly in accordance with this product specification. The company reserves the right to change the contents of this specification without prior notice; the final interpretation right of this information belongs to the company.

N-Type High efficiency

Bifacial Dual Glass Module

SGN-450-BDG5



Bifacial technology allows for the harvesting of up to an additional 30% energy from the rear side of the module.



30 years lifespan brings 10-30% additional power generation comparing with conventional P-type module.



N-type solar cell has no LID naturally which can increase power generation.



Excellent low irradiance performance.



Enhanced light trapping and optimized current collection contribute to the improvement of both module power output and reliability.



Industry leading lowest thermal coefficient of power.



Design optimized for lower operating current, resulting in minimized hot spot loss and improved temperature coefficient.

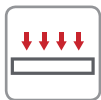

Certified to withstand: wind load (2400 Pa) and snow load (5400 Pa).



100% triple EL test enables remarkable reduction of module hidden crack rate.

LINEAR PERFORMANCE WARRANTY

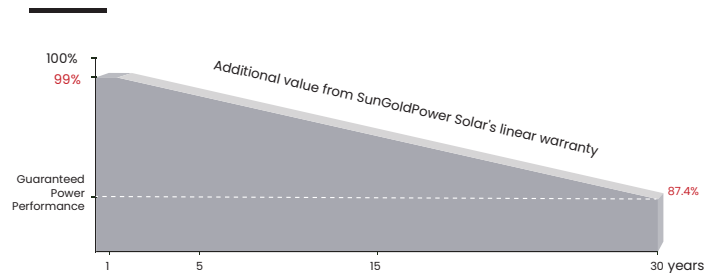

up to **12** years
Product quality & process guarantee

30 years
Linear power guarantee

0.40 %
Annual degradation Over 30 years

COMPREHENSIVE CERTIFICATES



UL61730 Certified by ETL,CEC Listed

ISO 9001: Quality Management System

ISO 14001: Environmental Management System Standard

ISO 45001: International Occupational Health and Safety Assessment System Standard

* Different markets have different certification requirements. Also, the products are under rapid innovation. Please confirm the certification status with regional sales representatives.

ELECTRICAL CHARACTERISTICS

Model of modules	SGN-450-BDG5	
	STC	NMOT
Peak power - P_{mp} (W)	450	338
Open circuit voltage - V_{oc} (V)	35.03	33.28
Short circuit current - I_{sc} (A)	16.05	12.96
MPP voltage - V_{mp} (V)	30.08	27.96
MPP current - I_{mp} (A)	14.97	12.09
Module efficiency - η_m (%)	22.5	

STC (Standard Testing Conditions): Irradiance 1000W/m², Cell Temperature 25 °C, Spectra at AM1.5

NMOT (Nominal Module Operating Temperature): Irradiance 800W/m², Ambient Temperature 20°C, Spectra at AM1.5, Wind at 1m/s

ELECTRICAL CHARACTERISTICS WITH DIFFERENT POWER BIN (REFERENCE TO 13.5% IRRADIANCE RATIO)

Peak power - P_{mp} (W)	499
Open circuit voltage - V_{oc} (V)	35.03
Short circuit current - I_{sc} (A)	17.78
MPP voltage - V_{mp} (V)	30.08
MPP current - I_{mp} (A)	16.59
Irradiance ratio (rear/front)	13.5 %

STRUCTURAL CHARACTERISTICS

Module dimension (L*W*H)	69.37 x 44.65 x 1.38 inch (1762 x 1134 x 35 mm)
Weight	53.35 lbs (24.2 kg)
Number of cells	96 cells
Cell	N-type monocrystalline (7.17 X 8.27 inch (182X210 mm))
Front Glass	2.0mm, Anti-Reflection Coating
Back Glass	2.0mm, Heat Strengthened Glass
Frame	Black anodized aluminum alloy
Junction box	IP68 rated (3 diodes)
Output wire	4mm ² (IEC),12 AWG (UL)
Wire length (Including Connector)	+400/-200mm (+15.75/-7.87in.)or customized
Connector	MC4 Compatible
Pieces per Pallet	31 pcs/Pallet
Pieces per Container (Normal/Weight-limited area)	806/744 pcs/40'HQ

OPERATING PARAMETERS

Power tolerance (W)	(0,+5)
Maximum system voltage (V)	1500
Maximum rated fuse current (A)	30
Current operating temperature (°C)	-40~+185 °F (-40~+85 °C)
Bifaciality	80±10 %
Fire performance	Type 29

MECHANICAL LOADING

Front side maximum static loading (Pa)	5400
Rear side maximum static loading (Pa)	2400
Hailstone test (mm)	35

TEMPERATURE RATINGS

Temperature coefficient (P_{max})	-0.29 %/K
Temperature coefficient (V_{oc})	-0.28 %/K
Temperature coefficient (I_{sc})	+0.04 %/K
Nominal Module Operating Temperature	109.4±35.6 °F (43±2 °C)

MODULE DIMENSIONS (MM)

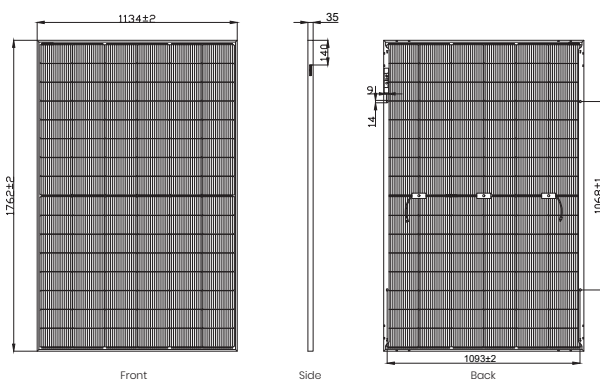

Characteristic curves (450W)

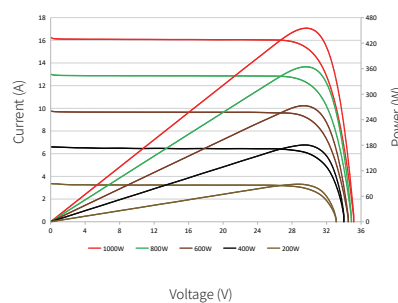

Temperature Dependence of I_{sc} , V_{oc} , P_{max}

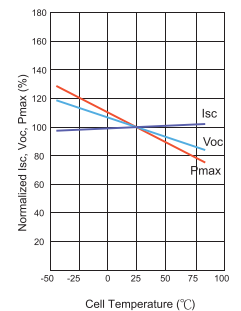

User Manual

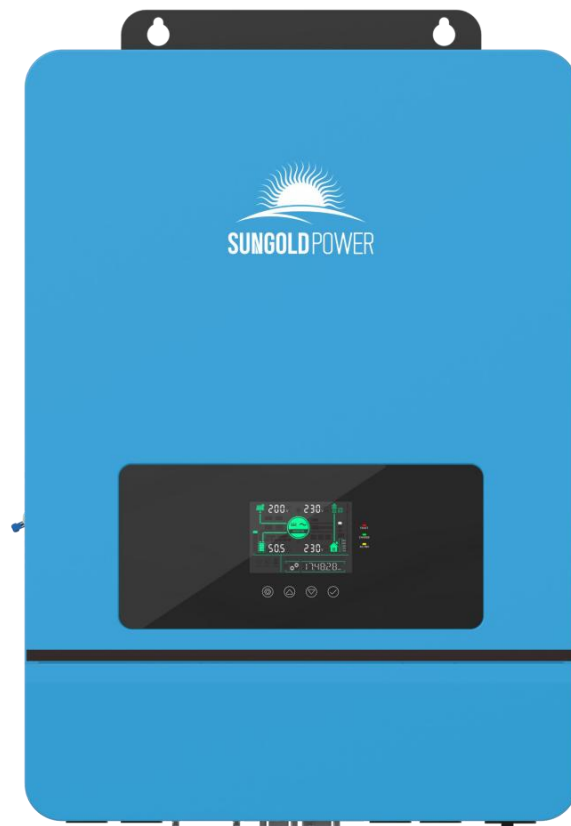

All-in-one solar charge inverter

SPH8048P

SPH10048P

Contents

1. Safety	1
1.1 About this Manual	1
1.2 Symbols and description	1
1.3 Safety matters	1
2. About the Product	2
2.1 Description	2
2.2 Features	2
2.3 System connection diagram	3
2.4 Product overview	4
3. Installation	5
3.1 Installation location	5
3.2 Inverter installation	6
3.3 Removal of terminal cover and insect-proof net	6
4. Wiring	7
4.1 Wiring mode (depends on the output mode)	7
4.2 Cable and circuit breaker model	10
4.3 AC input and output wiring	12
4.4 Battery wiring	12
4.5 PV wiring	13
4.6 Dry contact wiring	13
4.7 Grounding	14
4.8 Inverter start	14
4.9 Parallel wiring	14
5. Operation	32
5.1 Operation and display panel	32
5.2 Setting	36
5.3 AC output mode	43
5.4 Battery charge mode	45
5.5 Timed charge/discharge function	46
5.6 Battery parameters	47
6. Communication	49
6.1 Overview	49
6.2 USB-B port	49
6.4 RS485/CAN port	50
6.5 Dry contact port	51

7. Fault Codes and Response Measures 52

 7.1 Fault codes 52

 7.2 Troubleshooting 54

8. Protection Function and Maintenance 56

 8.1 Protection function 56

 8.2 Maintenance 57





9. Parameter Table 58

1. Safety

1.1 About this Manual

- This Manual contains important information, guiding principles, operation, and maintenance of the product, and applies to the model: SPH U series
- Users must follow the instructions in this Manual during installation, use, and maintenance.

1.2 Symbols and description

Symbol	Description
 DANGER	Dangerous situations that will lead to death or serious injury when ignored.
 WARNING	Dangerous situations that may lead to death or serious injury when ignored.
 CAUTION	Dangerous situations that may lead to mild or moderate injury when ignored.
 NOTICE	Operation tips.

1.3 Safety matters

DANGER

- This chapter contains important safety matters. Please read and keep this Manual for future reference.
- Please make sure to comply with local requirements and regulations when installing the inverter.
- Be careful of high voltage. Before and during installation, please turn off the switch of each power supply to avoid electric shock.
- In order to achieve optimal operation of the inverter, please select the appropriate cable size and necessary protective devices according to regulations.
- Do not connect or disconnect any connections when the inverter is working.
- Do not open the terminal cover when the inverter is working.
- Keep the inverter well-grounded.
- Avoid short circuits in AC output and DC input.
- Do not disassemble the inverter. Send the inverter to a professional service center for repair and maintenance.
- Do not charge frozen batteries.

2. About the Product

2.1 Description

SPH U series is a new type of solar storage inverter that integrates PV storage, mains charge, and energy storage and outputs sinusoidal AC. Equipped with DSP control and advanced control algorithm, it has high response speed and good reliability, and applies to industrial scenarios.

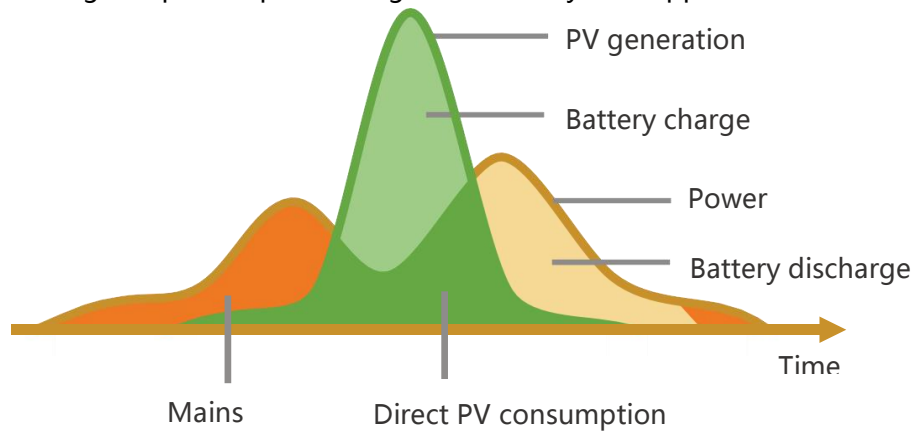

2.2 Features

- Support the connection of various types of energy storage batteries such as lead-acid battery and lithium-ion battery
- Have the dual activation function during lithium-ion battery sleep, that is, access to mains/PV power can activate the lithium-ion battery
- Support split-phase/single-phase pure sine wave output
- Support adjusting the voltage of each phase within the range of 100 VAC, 105 VAC, 110 VAC, 115 VAC, 120VAC, 127VAC
- Support two-channel PV input and have the function of simultaneous two-channel Max. power point tracking (MPPT) for charging/carrying capacity
- Support two-channel MPPT, with an efficiency of up to 99.9% and a maximum single-channel current of 22 A, perfectly fitting high-power modules
- Provide four charge modes: only PV, mains first, PV first, and mains + PV
- Have the timed charge and discharge function, that is, users can set the charge and discharge time according to the time-of-use price to save electricity costs
- Have the energy-saving mode, reducing no-load energy losses
- Provide two output modes: mains bypass output and inverter output, achieving uninterrupted power supply
- Support LCD display of dynamic flowchart, updating system data and operating status at any time
- Provide 360° protection, including short circuit protection, overcurrent protection, overvoltage and undervoltage protection, and overload protection
- Support CAN, USB, RS485 communication

2.3 System connection diagram

The following figure shows the system application scenario of the product. A complete system consists of the following parts:

1. **PV module:** It converts solar energy into DC to charge batteries or into AC to supply power to loads.
2. **Mains or generator:** Connected to AC input, it can charge batteries while supplying power to loads. When the battery and PV module supply power to the load, the system can generally operate without mains or generator.
3. **Battery:** The function of a battery is to ensure normal power supply for the system load when there is insufficient PV power and no mains.
4. **Household load:** It can connect various household and office loads, including refrigerators, lighting fixtures, TVs, fans, air conditioners, and other AC loads.
5. **Inverter:** It is the energy conversion device of the entire system.

- **The actual application scenario determines the specific system wiring mode**

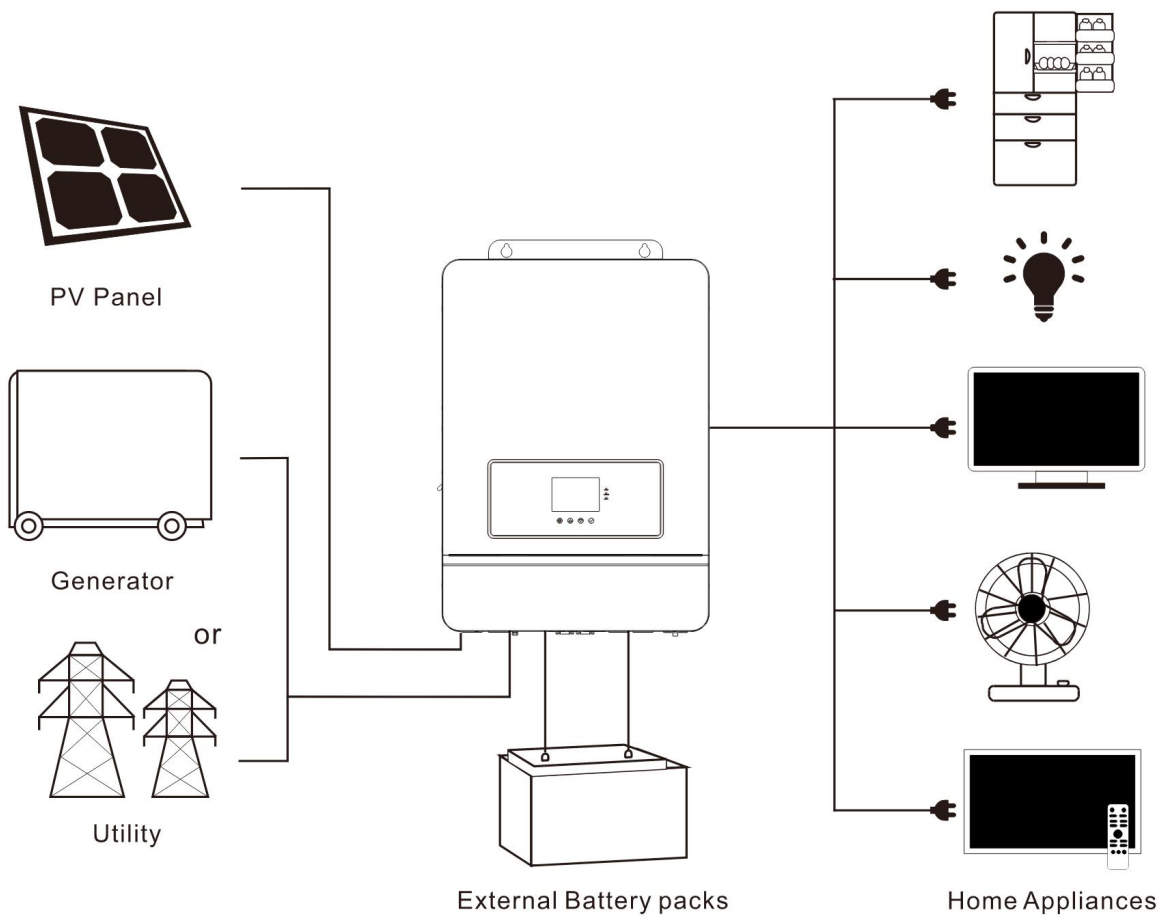

2.4 Product overview

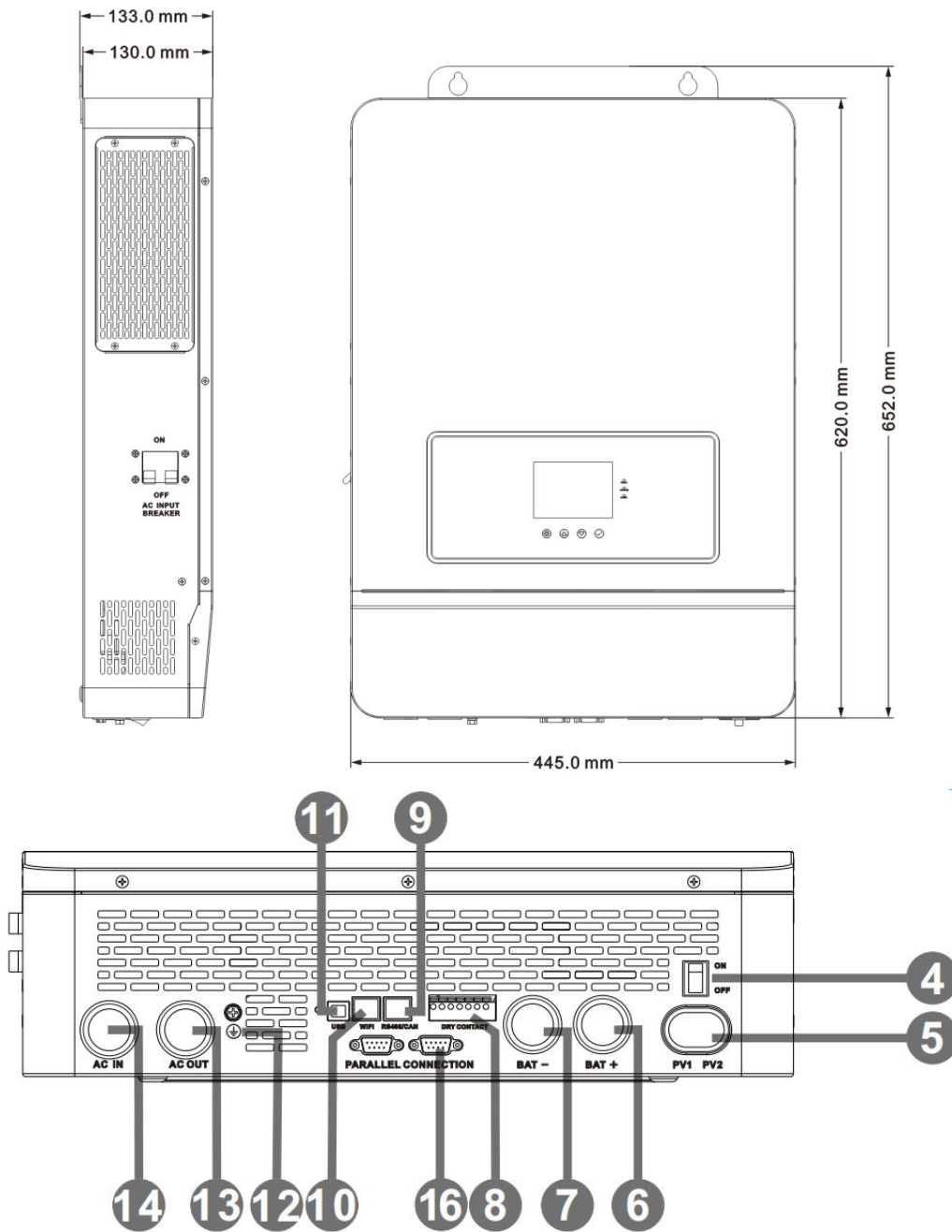

1	LCD screen	2	Physical button	3	LED indicator
4	ON/OFF rocker switch	5	PV input (1/1)	6	Battery (positive electrode)
7	Battery (negative electrode)	8	Dry contact	9	RS485/CAN port
10	WIFI port	11	USB-B port	12	Grounding screw
13	AC output (L1+L2+N)	14	AC input (L1+L2+N)	15	AC input circuit breaker
16	Parallel communication port				

3. Installation

3.1 Installation location

SPH U series is only for indoor use (**protection level: IP20**). Before selecting the installation location, users should consider the following factors:

- A solid wall
- Installation height: flush with the line of sight
- Sufficient heat dissipation space
- Ambient temperature: -10°C – 55°C (14°F – 131°F), to ensure optimal operation

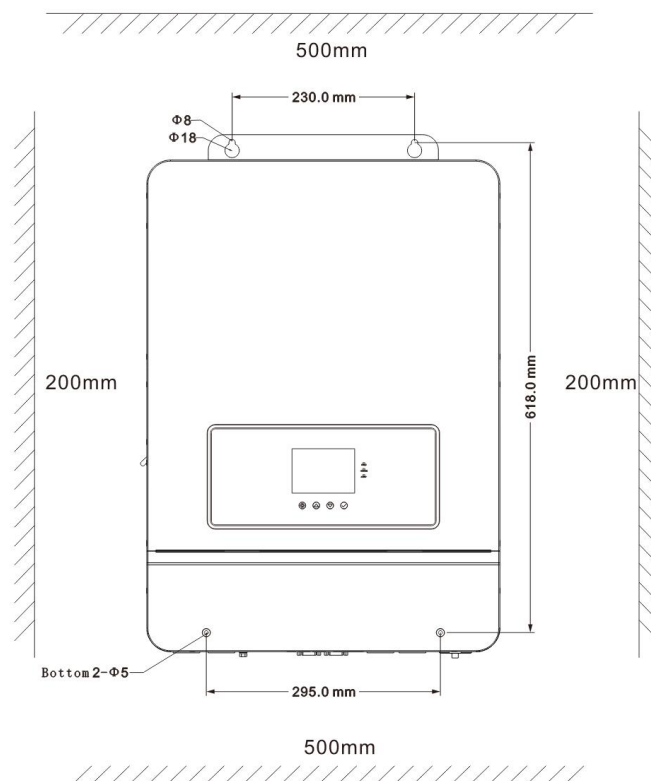

DANGER

- Do not install the inverter near highly flammable materials
- Do not install the inverter in potentially explosive areas
- Do not install the inverter and lead-acid battery in enclosed spaces

CAUTION

- Do not install the inverter in direct sunlight
- Do not install or use the inverter in damp environments

3.2 Inverter installation

Drill 4 installation holes of the specified sizes on the wall with an electric drill, insert 2 expansion screws above, and fix the inverter with 2 M5 screws below.

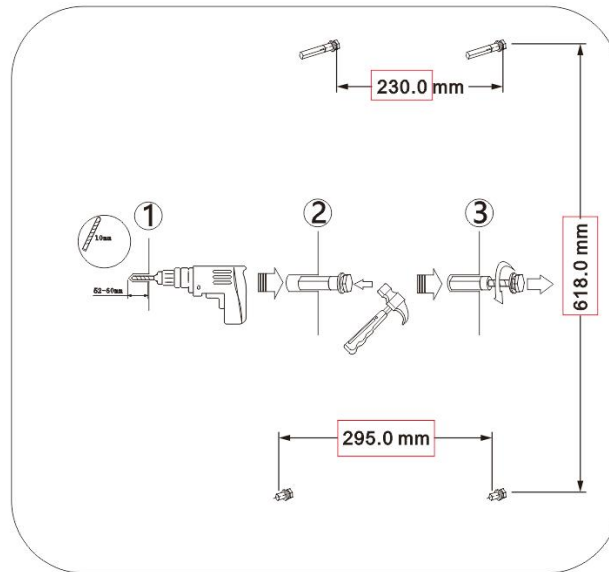

3.3 Removal of terminal cover and insect-proof net

Remove the terminal cover and insect-proof net with a screwdriver

Remove the insect-proof net when cleaning

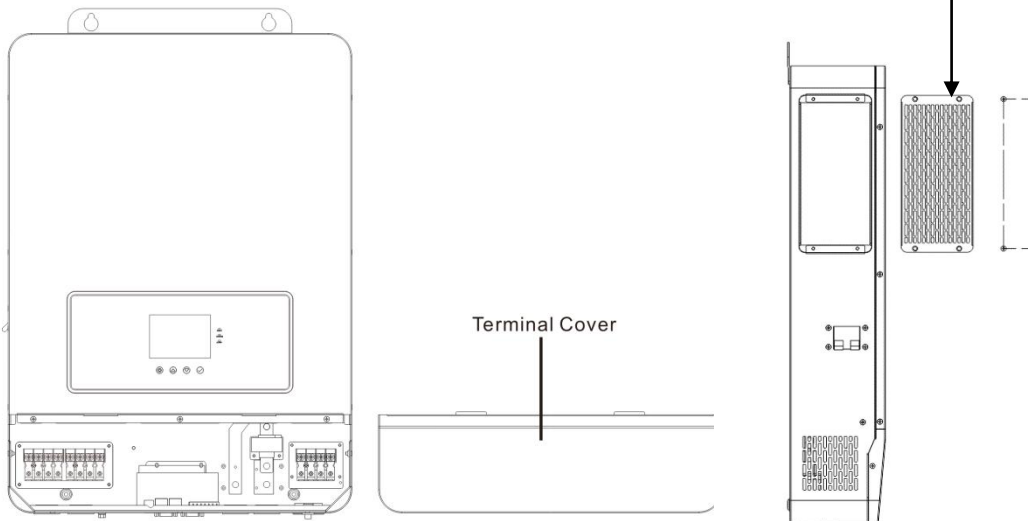

NOTICE

- When using the inverter in areas with poor air quality, the dustproof net is easily blocked by air particles. Please regularly remove and clean it to avoid affecting the air flow rate inside the inverter; otherwise it may cause inverter overheating (19/20 fault), and affect power supply and the service life of the inverter.

4. Wiring

4.1 Wiring mode (depends on the output mode)

- Split-phase mode (default)

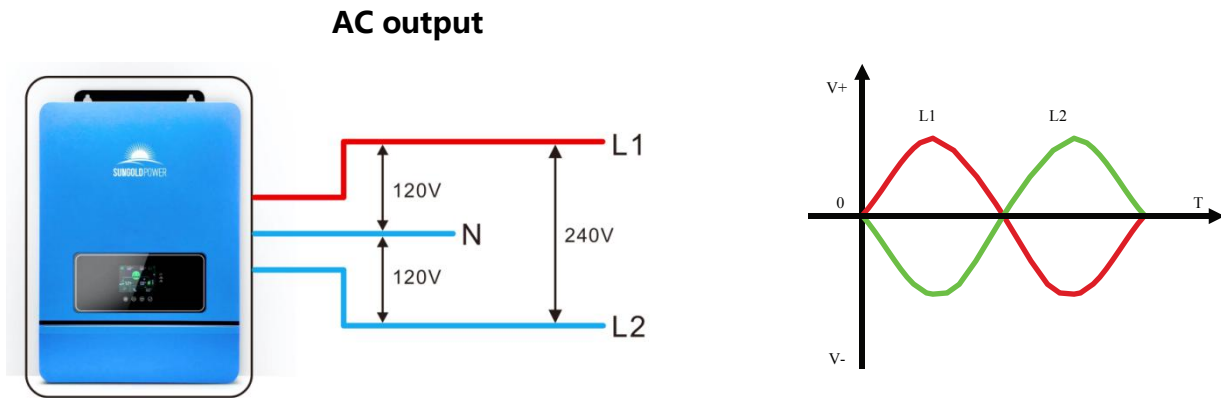

Item	Description
Applicable model	SPH series
AC output phase voltage (L-N)	100 VAC–120 VAC, 120 VAC (default)
AC output line voltage (L-L)	200 VAC–240 VAC, 240 VAC (default)

- Single-phase mode

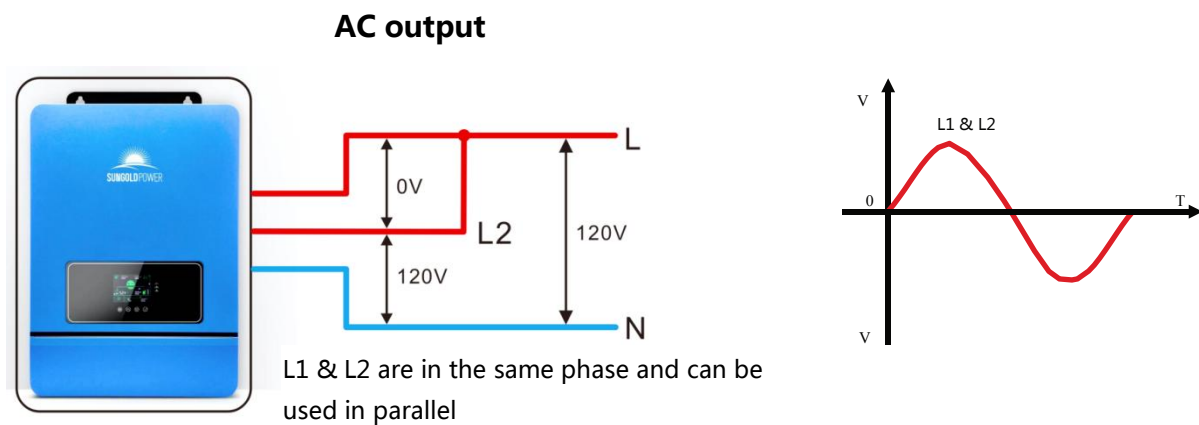

Item	Description
Applicable model	SPH series
AC output phase voltage (L-N)	100 VAC–120 VAC, 120 VAC (default)

Split-phase Mode

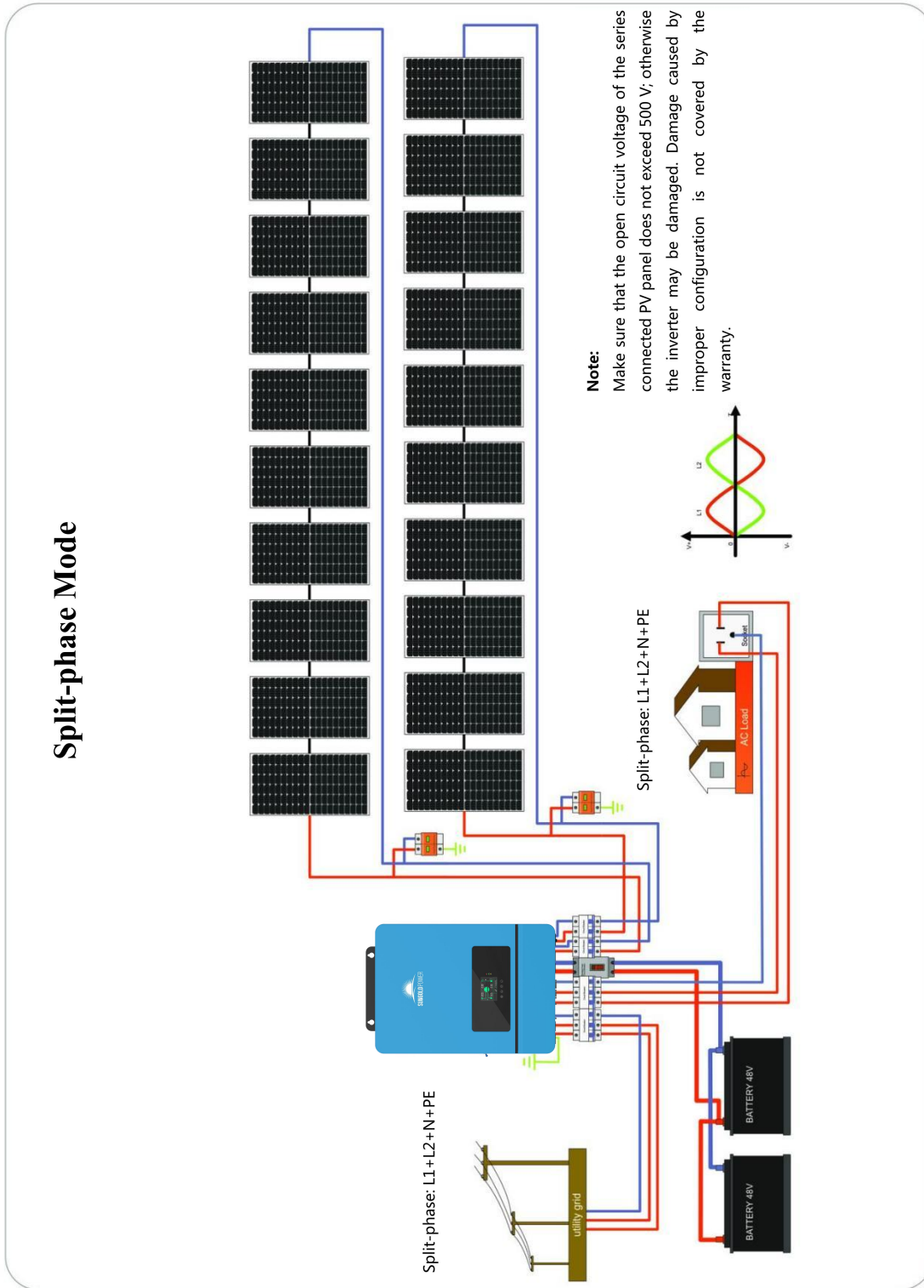

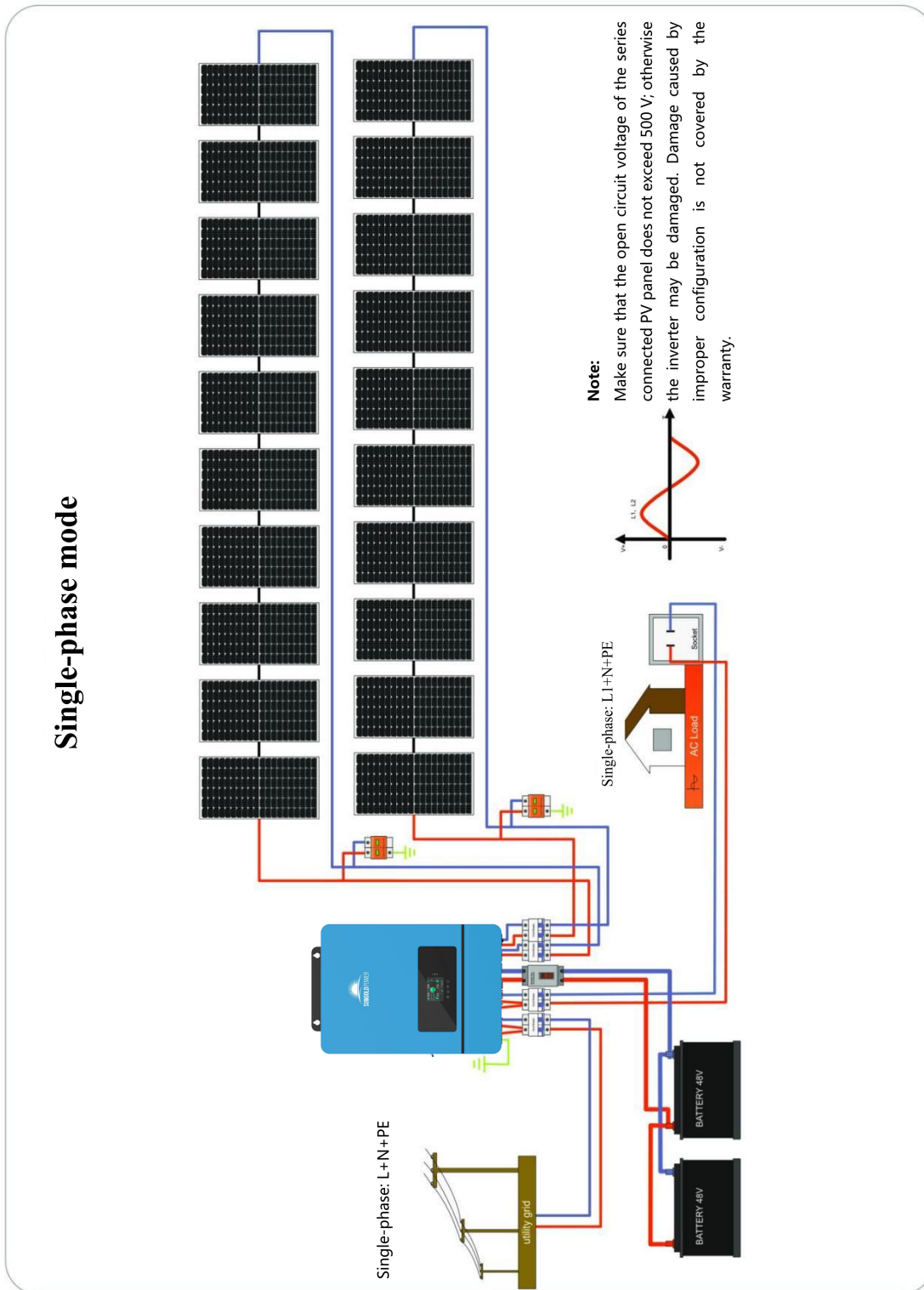

4.2 Cable and circuit breaker model

• PV INPUT

Inverters Models	Cable Size	Max. Input Current	Circuit Breaker Model
SPH8048P	4 mm ² /12 AWG	22A	2P-25A
SPH10048P	4 mm ² /12 AWG	22A	2P-25A

• AC INPUT

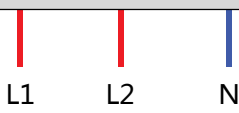
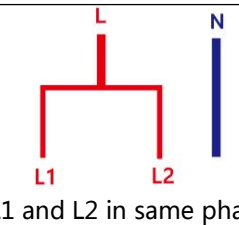
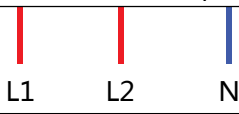
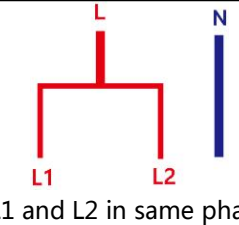
Inverter Models	Output Mode	Diagram	Max. Current	Cable Size	Circuit Breaker Model
SPH8048P	Split-phase mode		63A (L1/L2/N)	13mm ² /8 AWG (L1/L2/N)	3P-63A
	Single-phase mode		63A (L1/L2) 126 A (N)	13mm ² /8 AWG (L1/L2) 26 mm ² /3 AWG (N)	2P-125A
SPH10048P	Split-phase mode		63A (L1/L2/N)	13mm ² /8 AWG (L1/L2/N)	3P-63A
	Single-phase mode		63A (L1/L2) 126A (N)	13mm ² /8 AWG (L1/L2) 26mm ² /3 AWG (N)	2P-125A

• Battery

Inverter Models	Cable Size	Max. Current	Circuit Breaker Model
SPH8048P	50 mm ² /0 AWG	180A	2P-200A
SPH10048P	70 mm ² /00 AWG	220A	2P-250A

• **AC output**

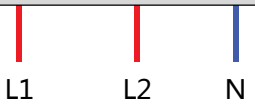
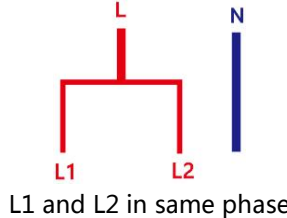
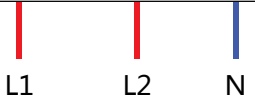
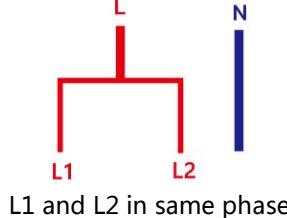
Inverter Models	Output Mode	Diagram	Max. Current	Cable Size	Circuit Breaker Model
SPH8048P	Split-phase mode		42A (L1/L2/N)	13mm ² /8 AWG (L1/L2/N)	3P-63A
	Single-phase mode		42A (L1/L2) 84 A (N)	13mm ² /8 AWG (L1/L2) 26mm ² /3 AWG (N)	2P-125A
SPH10048P	Split-phase mode		63A (L1/L2/N)	13mm ² /8 AWG (L1/L2/N)	3P-63A
	Single-phase mode		63A (L1/L2) 126 A (N)	13mm ² /8 AWG (L1/L2) 26mm ² /3 AWG (N)	2P-125A

NOTICE

• **PV input, AC input, and AC output terminals**

1. Use a wire stripper to strip off 6 mm – 8 mm long insulation layer of the cable.
2. Fix a sleeve at the end of the cable (the sleeve is to be prepared by the user)

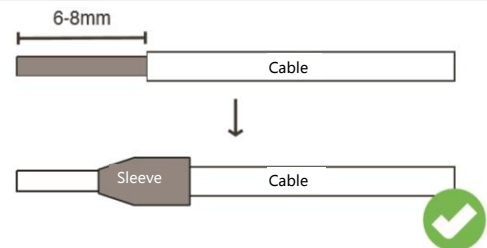

• **Battery terminal**

1. Use a wire stripper to strip off 6 mm – 8 mm long insulation layer of the cable.
2. Fix a ring terminal (attached) at the end of the cable

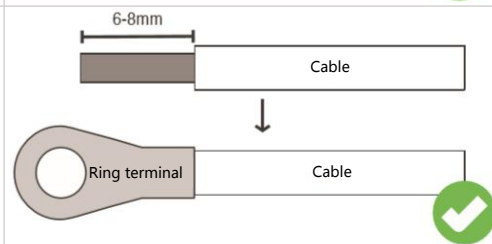

The cable size is for reference only. If the distance between the PV array and the inverter or between the inverter and the battery is long, using thicker cables will reduce voltage drop and improve system performance.

4.3 AC input and output wiring

Connect the live wire, neutral wire, and ground wire according to the cable position and sequence shown in the following figure.

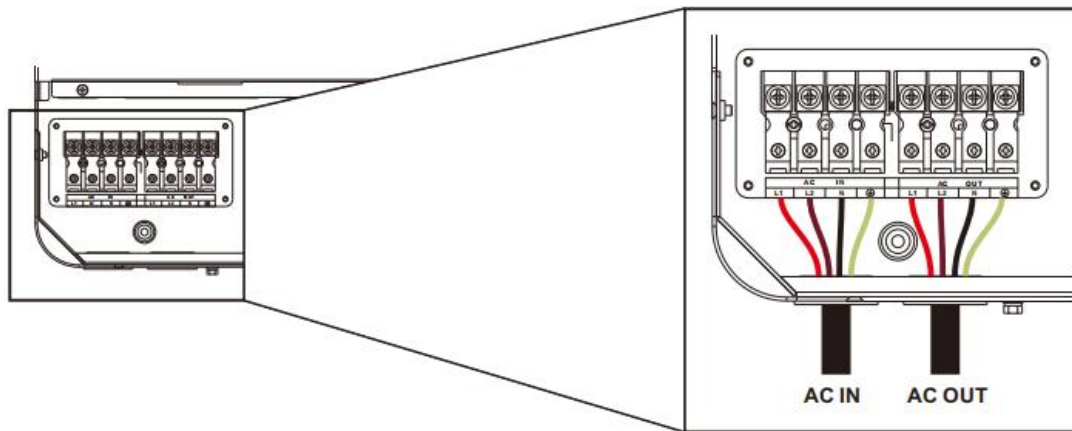

⚠ DANGER

- Before connecting AC input and output, be sure to disconnect the circuit breaker to avoid the risk of electric shock. Do not conduct live operation.
- Please check whether the cables used are sufficient to meet the requirements. Cables that are too thin or of poor quality may pose serious safety hazards.

4.4 Battery wiring

Connect the positive and negative cables of the battery according to the cable position and sequence shown in the following figure.

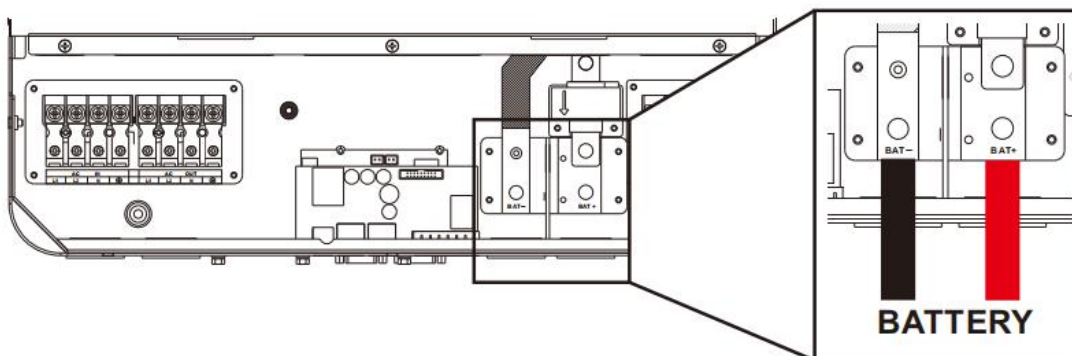

⚠ DANGER

- Before connecting the battery, be sure to disconnect the circuit breaker to avoid the risk of electric shock. Do not conduct live operation.
- Please check the positive and negative terminals of the battery for correct connection and no reverse connection; otherwise it may damage the inverter.
- Please check whether the cables used are sufficient to meet the requirements. Cables that are too thin or of poor quality may pose serious safety hazards.

4.5 PV wiring

Connect the positive and negative terminals of the two-channel PV modules according to the cable position and sequence shown in the following figure.

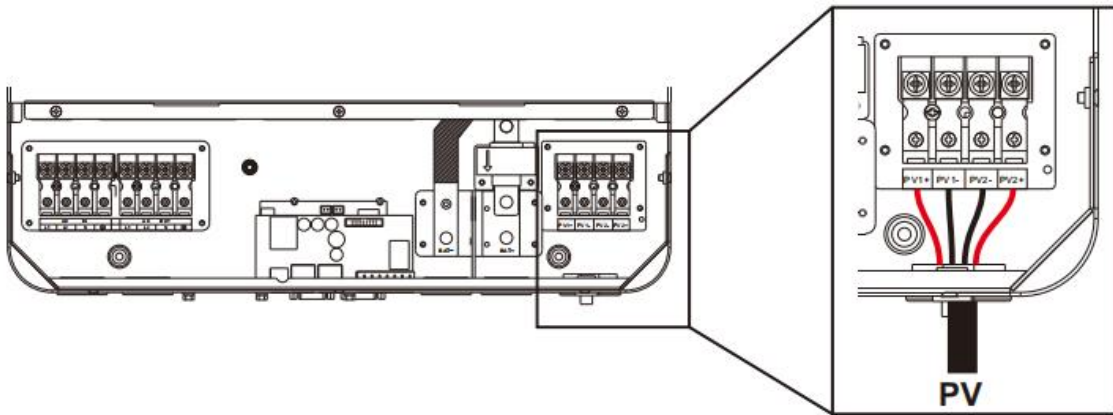

⚠ DANGER

- Before connecting PV modules, be sure to disconnect the circuit breaker to avoid the risk of electric shock. Do not conduct live operation.
- Please make sure that the open circuit voltage of the series connected PV modules does not exceed the maximum open circuit voltage of the inverter (in SPH series, this value is 500 V); otherwise the inverter may be damaged.

4.6 Dry contact wiring

Use a small-sized screwdriver to push back in the direction indicated by the arrow, and then insert the communication cable into the dry contact port. (Communication cable section: 0.2 mm²–1.5 mm²).

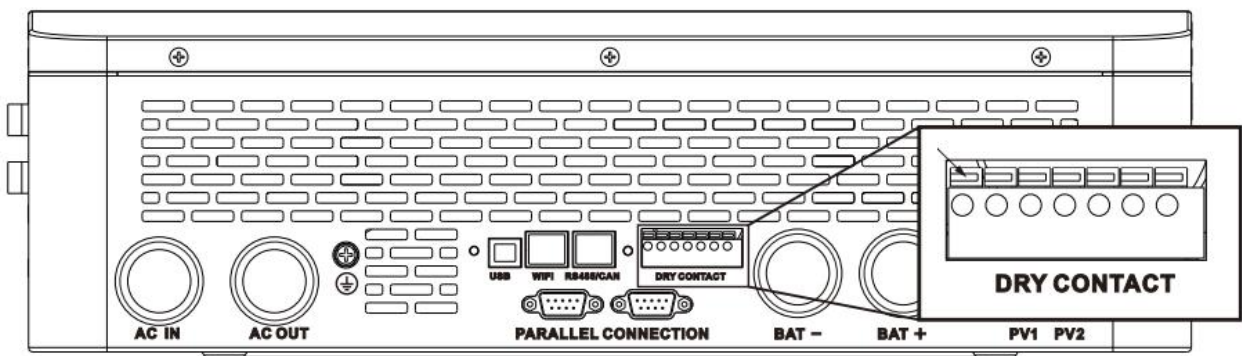

4.7 Grounding

Please ensure that the grounding terminal is reliably connected to the grounding busbar.

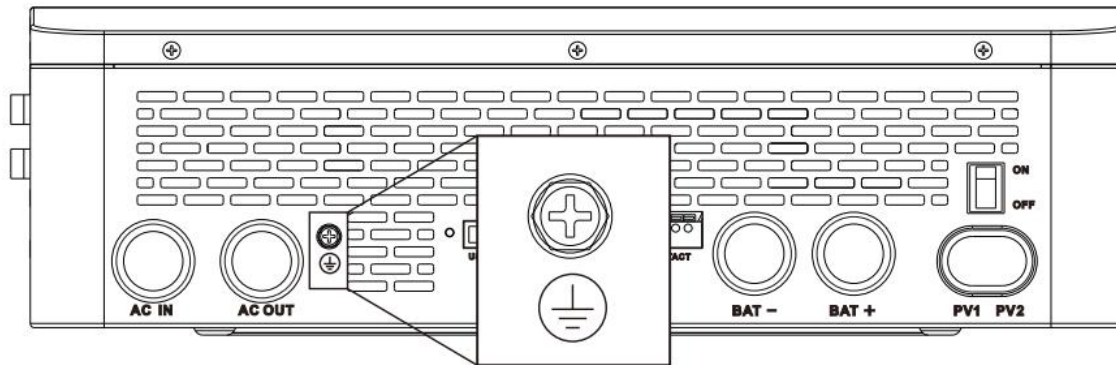

ⓘ NOTICE

- The grounding cable size shall not be less than 4 mm² and shall be as close as possible to the grounding point.

4.8 Inverter start

After confirming reliable wiring and correct wiring sequence, restore the terminal cover to its original position.

- Step 1: Close the circuit breaker of the battery.
- Step 2: Press the rocker switch at the bottom of the inverter, and the screen and indicator will light up, indicating that the inverter is enabled.
- Step 3: Close the circuit breakers for PV input, AC input, and AC output in sequence.
- Step 4: Start loads one by one in order of power from small to large.

4.9 Parallel wiring

4.9.1 Parallel operation

1. The parallel operation supports up to six solar storage inverters.
2. When using the parallel function, it is necessary to connect the parallel communication cable in a correct and reliable manner. See the figure below for the communication cable (packaging accessory):

Parallel communication cable*1

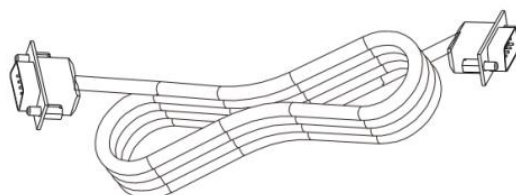

4.9.2 Cautions for parallel connection



Warning:

1. PV wiring:

In parallel connection, the PV array of each inverter must be independent, and the PV array of PV1 and PV2 for one inverter must also be independent.

2. Battery wiring

In single-phase or three-phase parallel connection, all solar storage inverters must be connected to the same battery, with BAT+ connected to BAT+ and BAT- to BAT-, and before power on and start-up, it is necessary to check and ensure correct connection, wiring length, and cable size, so as to avoid the abnormal operation of parallel system output caused by wrong connection.

3. AC OUT wiring:

In single-phase parallel connection, all solar storage inverters must be connected in the manner of L-to-L, N-to-N, and PE-to-PE, and before power on and start-up, it is necessary to check and ensure correct connection, wiring length, and cable size, so as to avoid the abnormal operation of parallel system output caused by wrong connection.

In three-phase parallel connection, all solar storage inverters must be connected in the manner of N-to-N and PE-to-PE. The L lines of all inverters in the same phase shall be connected together, but the AC output L lines of different phases shall not be connected together. Other cautions are the same as those for single-phase parallel connection.

4. AC IN wiring:

In single-phase parallel connection, all solar storage inverters must be connected in the manner of L-to-L, N-to-N, and PE-to-PE, and before power on and start-up, it is necessary to check and ensure correct connection, wiring length, and cable size, so as to avoid the abnormal operation of parallel system output caused by wrong connection. Meanwhile, it is not allowed to have multiple different AC source inputs to avoid damage to the external equipment of the inverter. The AC source input shall be consistent and unique.

In three-phase parallel connection, all solar storage inverters must be connected in the manner of N-to-N and PE-to-PE. The L lines of all inverters in the same phase shall be connected together, but the AC output L lines of different phases shall not be connected together. Other cautions are the same as those for single-phase parallel connection.

5. Communication wiring:

Our company's communication cable for parallel operation is a DB15 standard computer cable with shielding function, and it is used for single-phase or three-phase parallel connection. Each inverter shall be connected with one out and one in, that is, the male connector (out) of the inverter is to be connected to the female connector (in) of the parallel inverter, not the one of the inverter. In addition, DB15 terminal screws will be used to tighten the communication cable of

each parallel inverter to avoid falling off or poor contact of the communication cable, followed by abnormal operation or damage of the system output.

6. Before and after connecting the system, please carefully refer to the following system wiring diagrams to ensure that all wiring is correct and reliable before power on.
7. After the system is correctly wired, powered on, and in normal operation, if a new inverter needs to be connected, make sure to disconnect the battery input, PV input, AC input and AC output, and that all solar storage inverters are powered off before reconnecting into the system.

4.9.3 Wiring diagram for single-phase parallel connection (phase difference between L1 and L2: 0°)

- The communication cable of parallel solar storage inverter is to be locked with screws after connecting. See the diagram below:

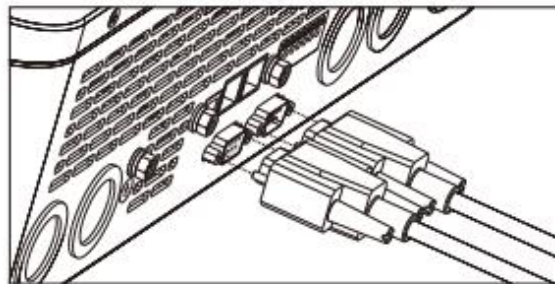

- See the diagram below for parallel connection

Set the item [31] to "PAL" and the item [68] to "0°." When setting the item [38] to "120 V," the output L-N voltage is 120 V

1. Two parallel-connected solar storage inverters:

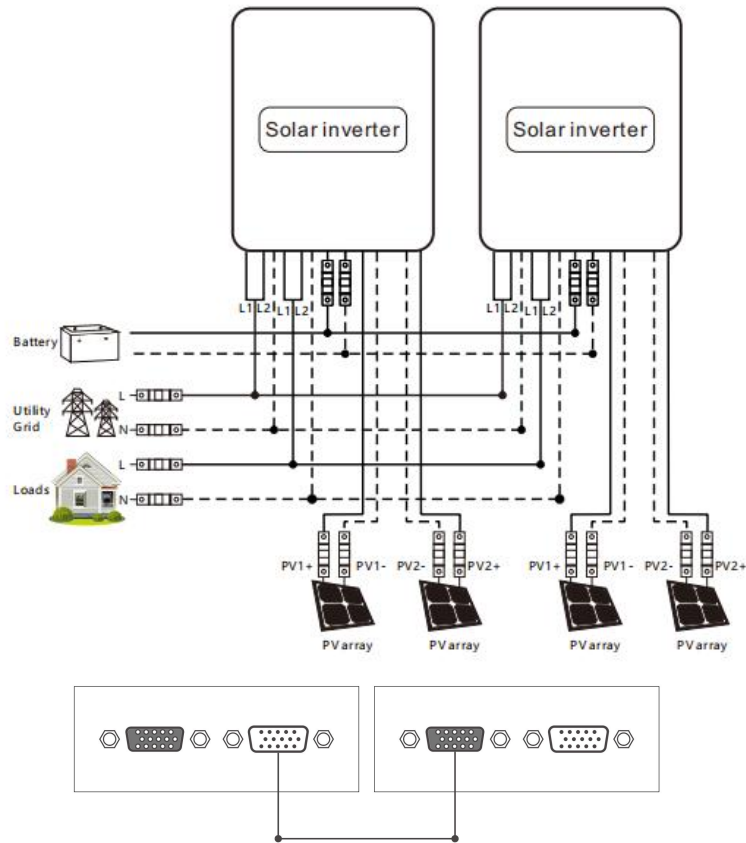

2. Three parallel-connected solar storage inverters:

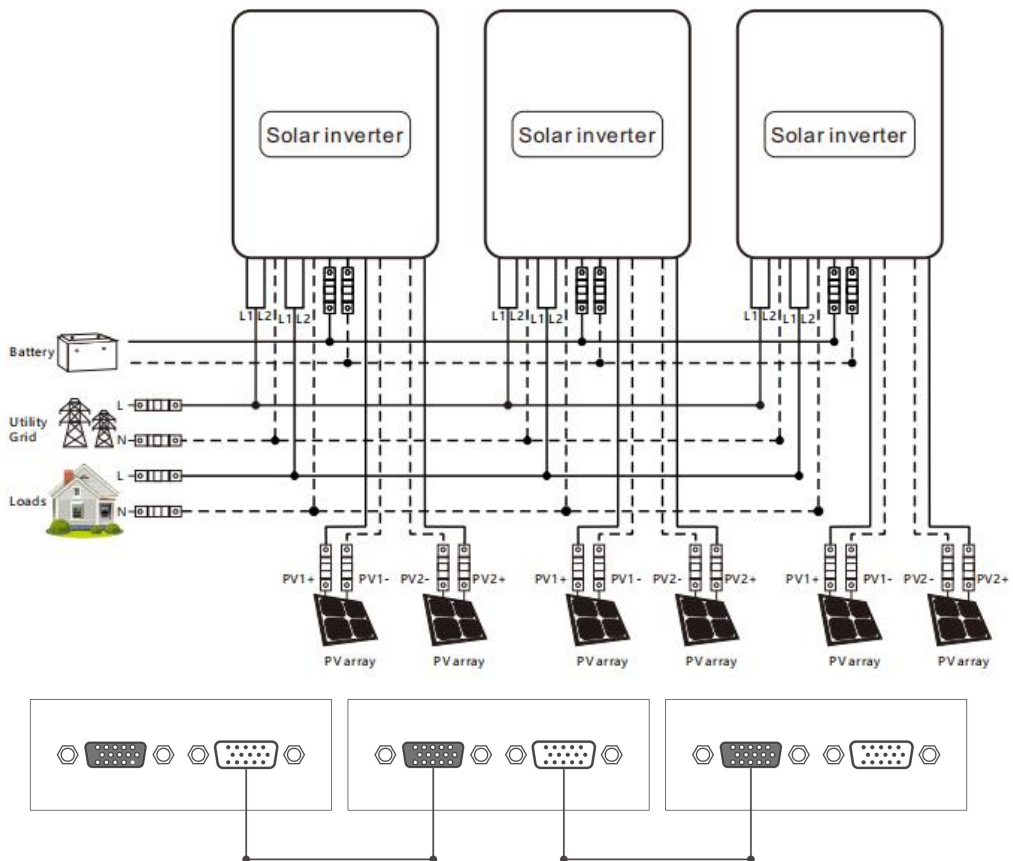

3. **Four parallel-connected solar storage inverters:**

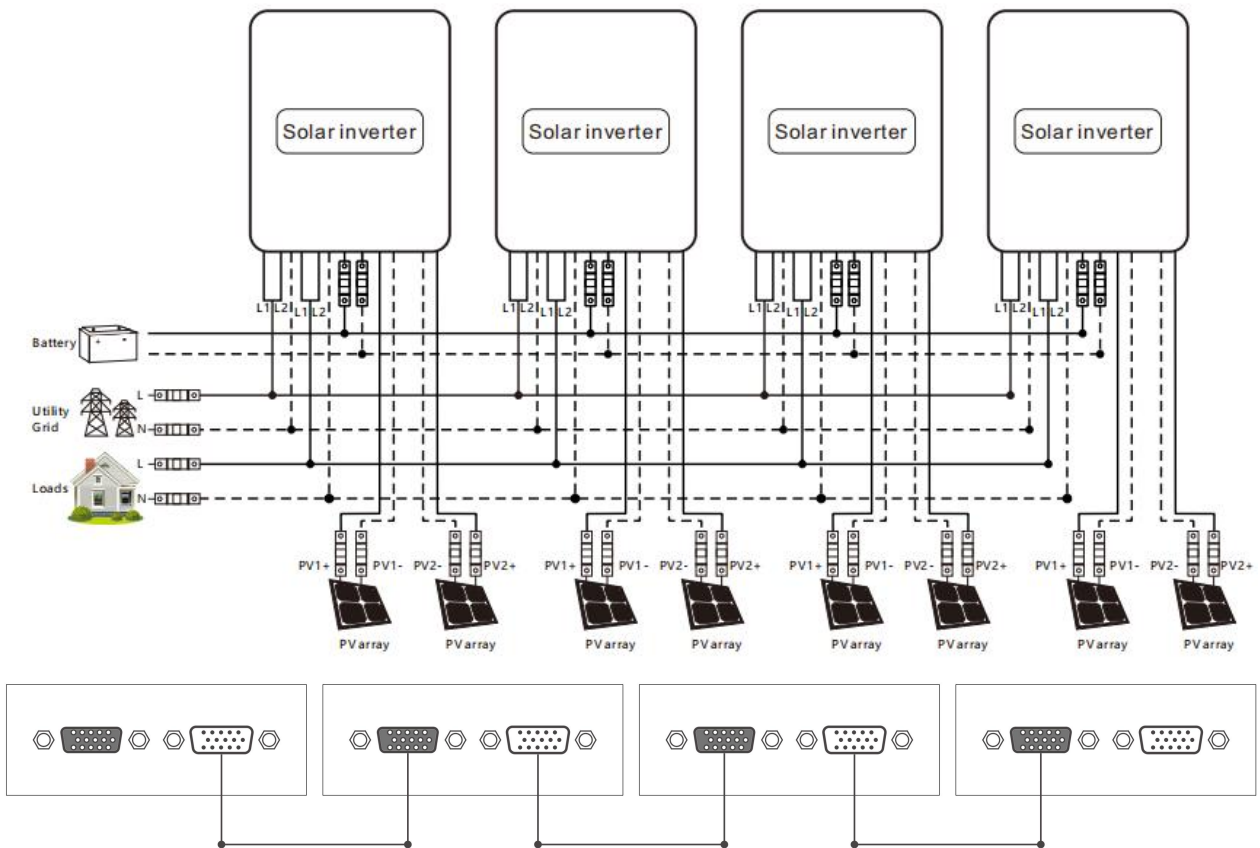

4. **Five parallel-connected solar storage inverters:**

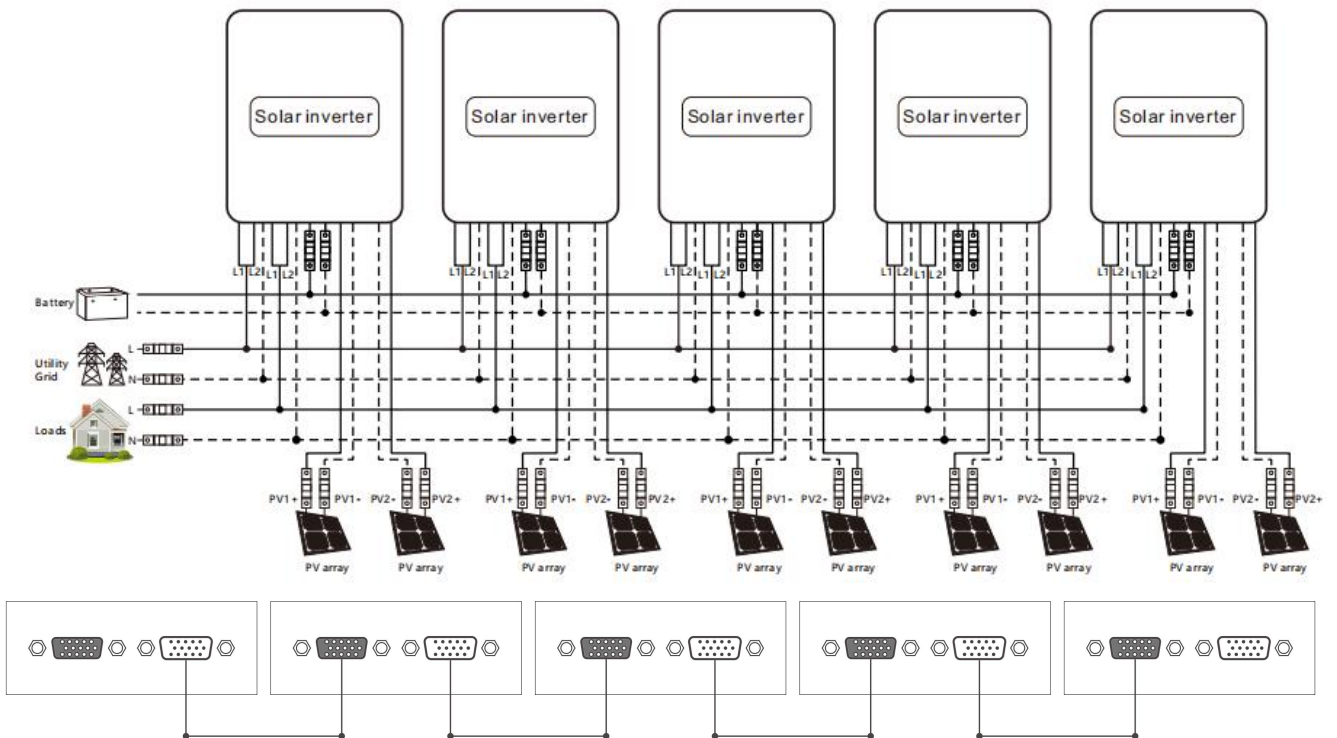

5. **Six parallel-connected solar storage inverters:**

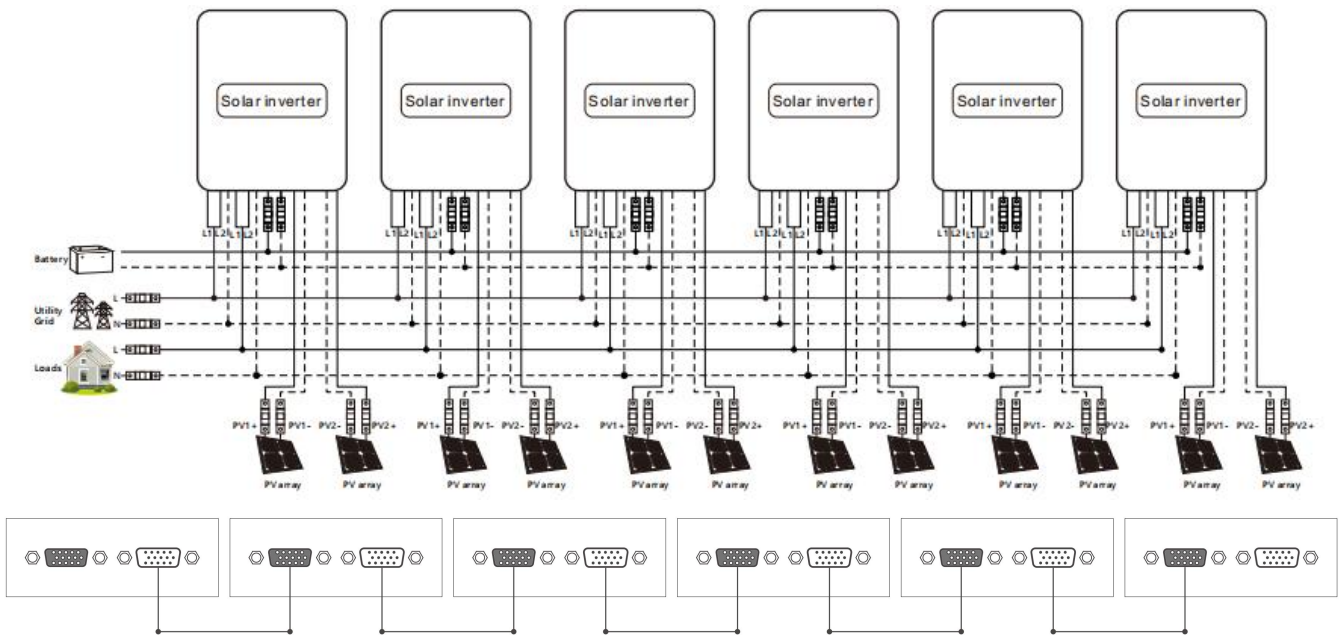

4.9.4 Wiring diagram for two-phase parallel connection (phase difference between L1 and L2: 0°)

- (1) P1: Set the item [31] to "2P0;" P2: Set the item [31] to "2P1," all of the P1/P2 inverter item [68] can not be set, it is default "0°" and the phase difference between P1 and P2 is 120°. When setting the item [38] to "120 V," the voltage between the live wire L1 of P1 phase and the live wire L2 of P2 phase is 208 V, and the L1-N voltage is 120 V
- (2) P1: Set the item [31] to "2P0;" P2: Set the item [31] to "2P2," all of the P1/P2 inverter item [68] can not be set, it is default "0°" and the phase difference between P1 and P2 is 180°. When setting the item [38] to "120 V," the voltage between the live wire L1 of P1 phase and the live wire L2 of P2 phase is 240 V, and the L1-N voltage is 120 V, L2-N voltage is 120V

a. Split-phase system (two inverters)
1+1 system:

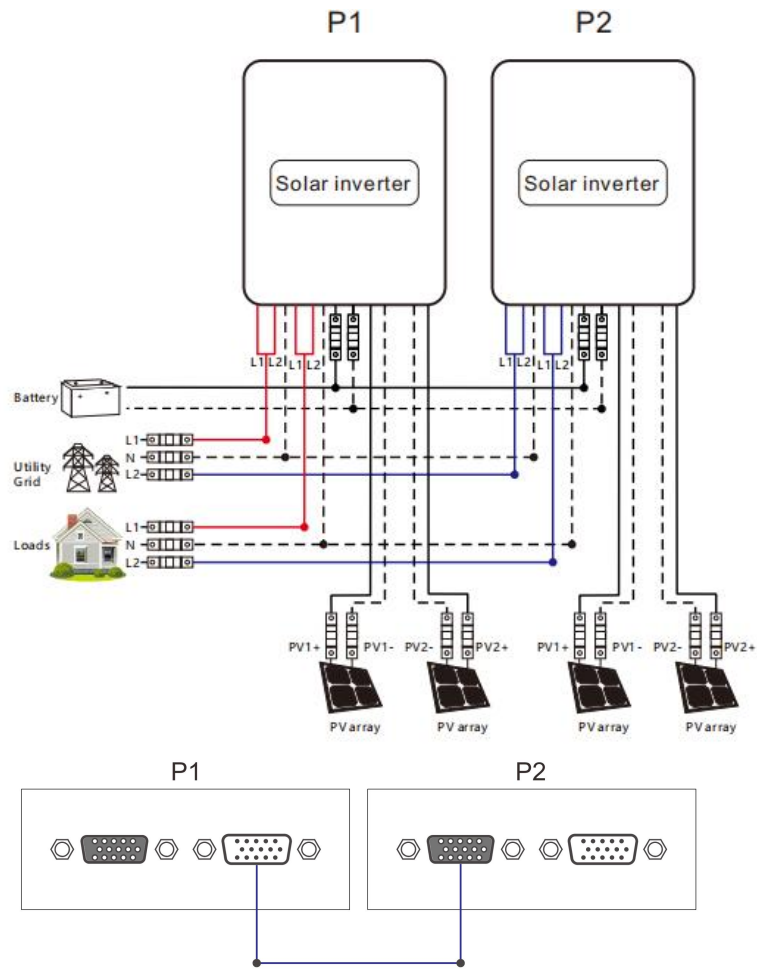

**b. Split-phase system (three inverters)
2+1 system**

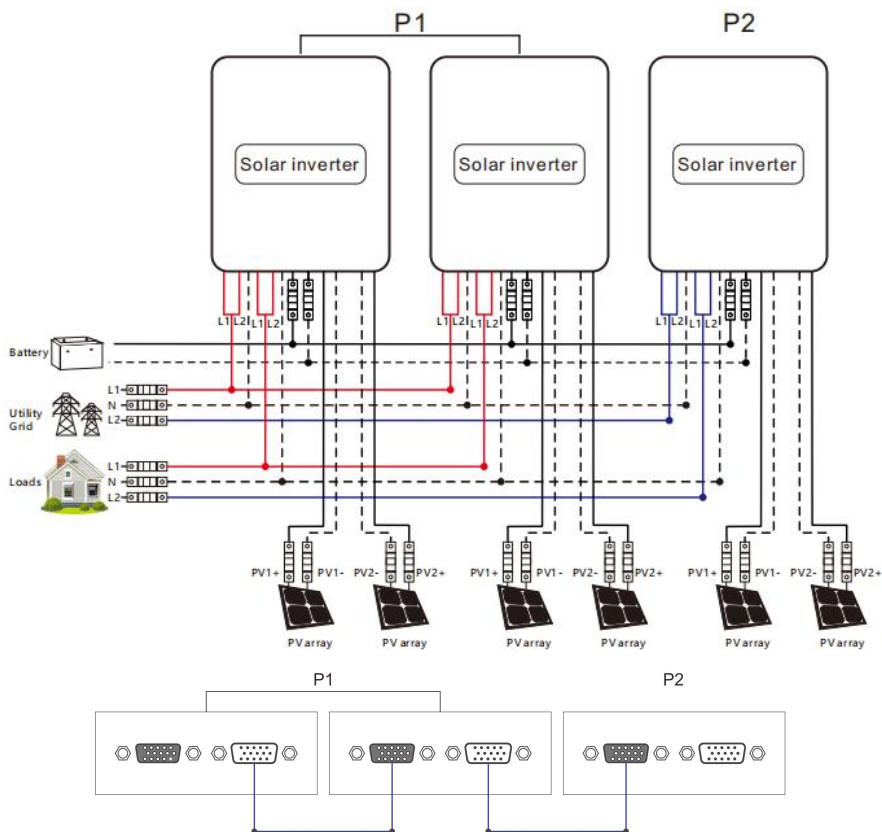

c. Split-phase system (four inverters)

3+1 system:

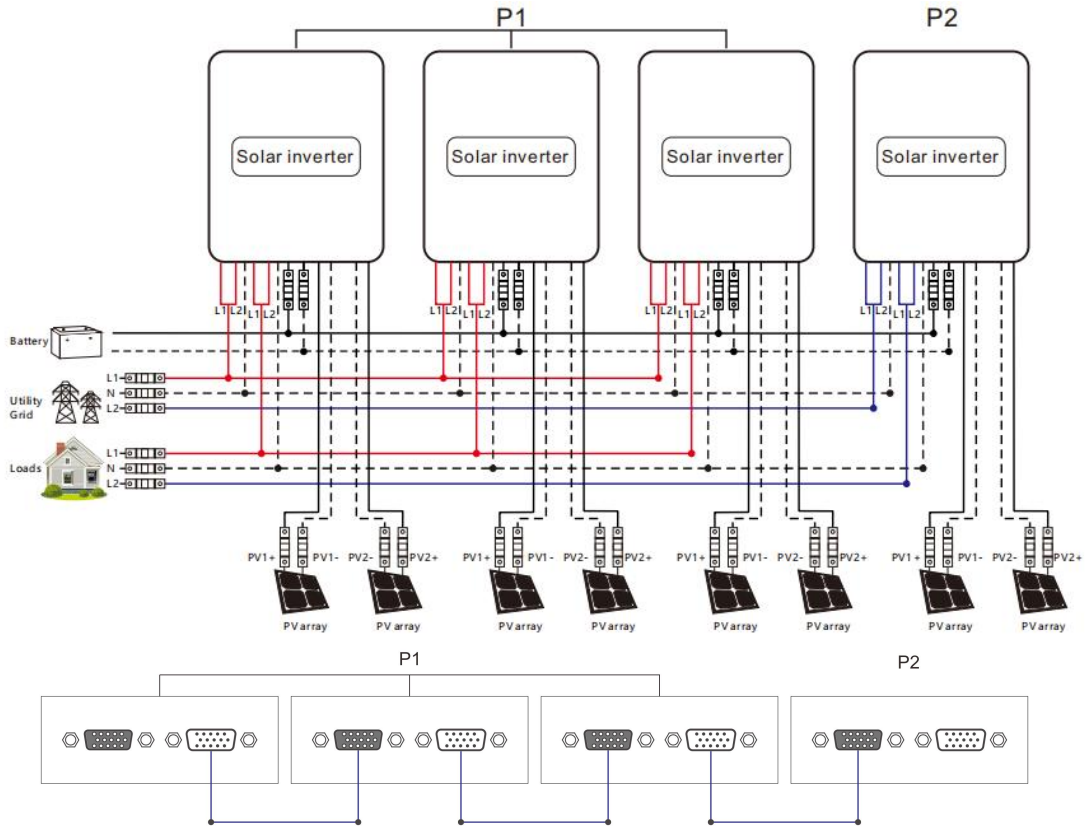

2+2 system:

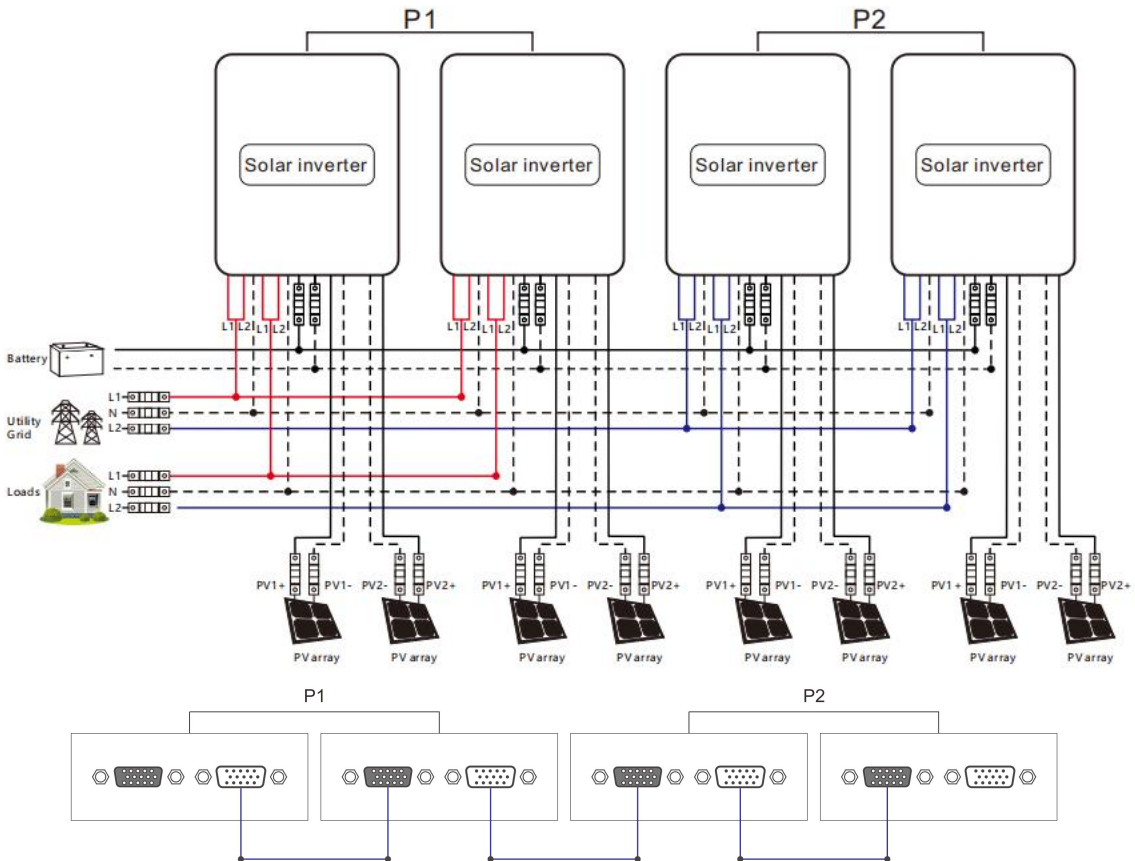

d. Split-phase system (five inverters)

4+1 system:

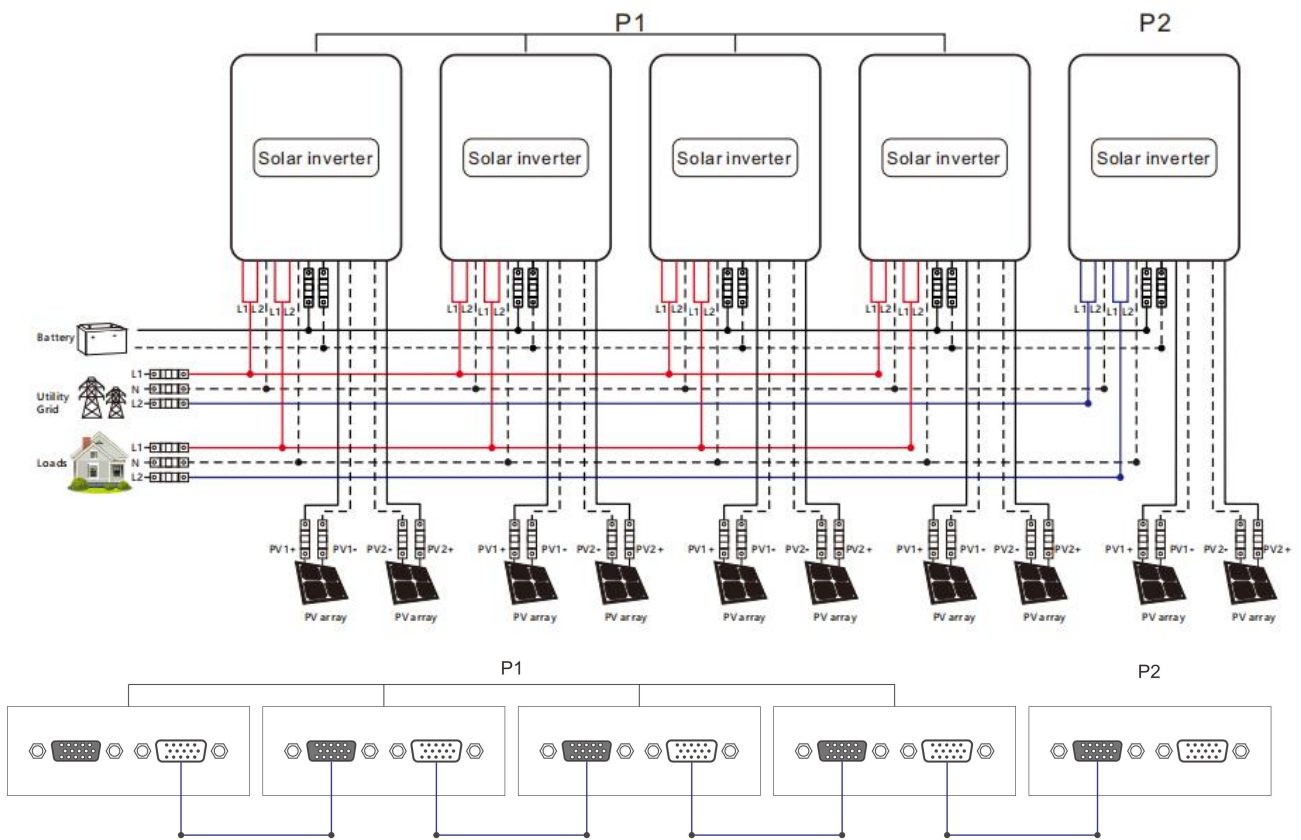

3+2 system:

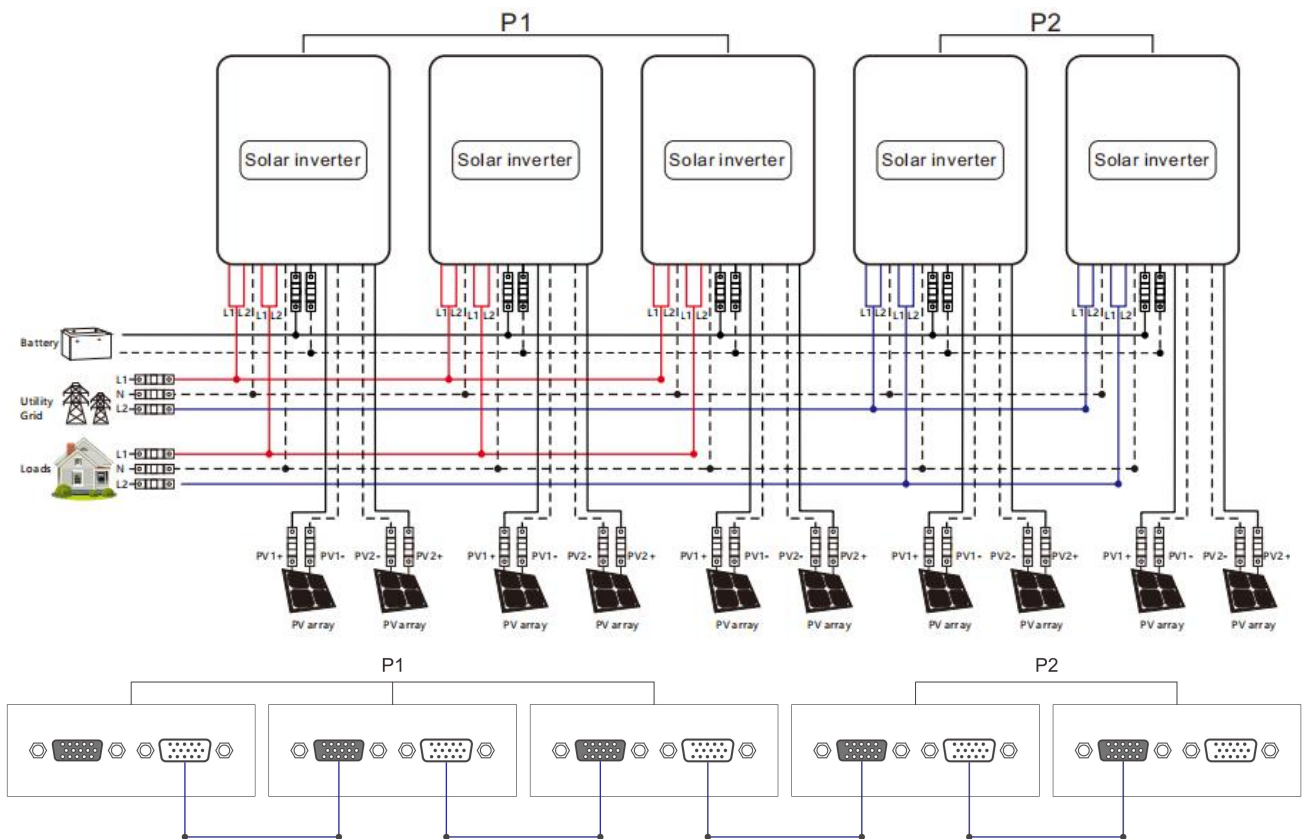

e. Split-phase system (six inverters)

5+1 system:

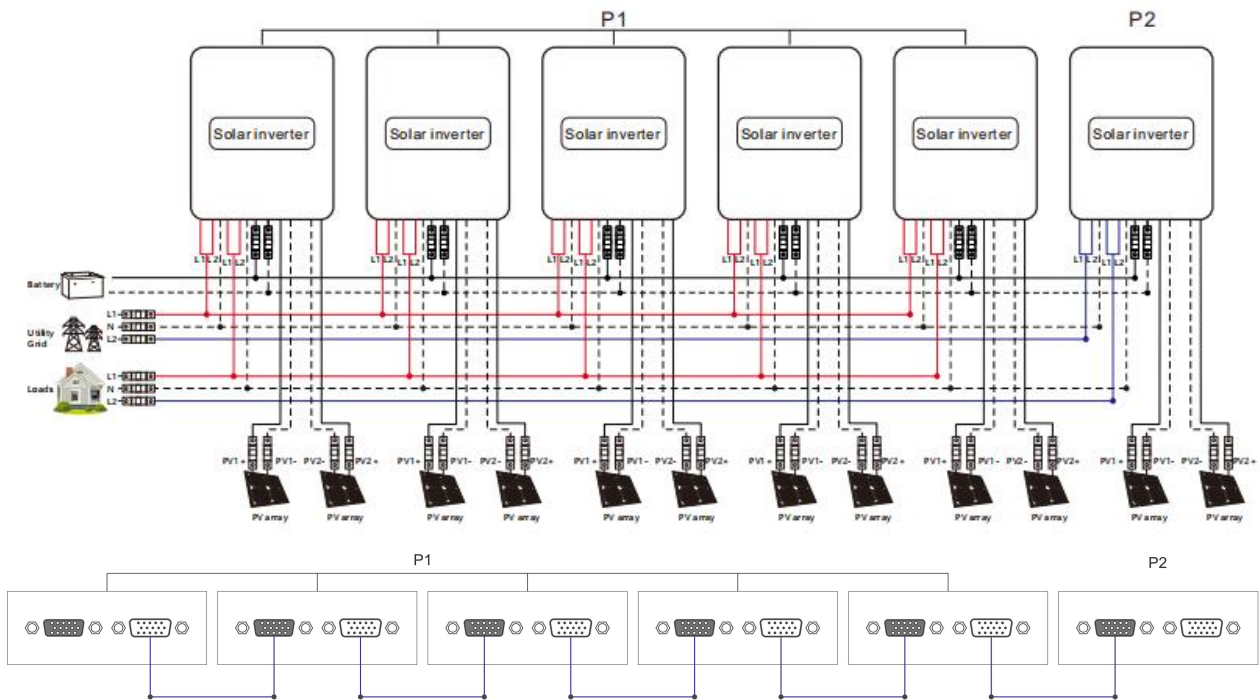

4+2 system:

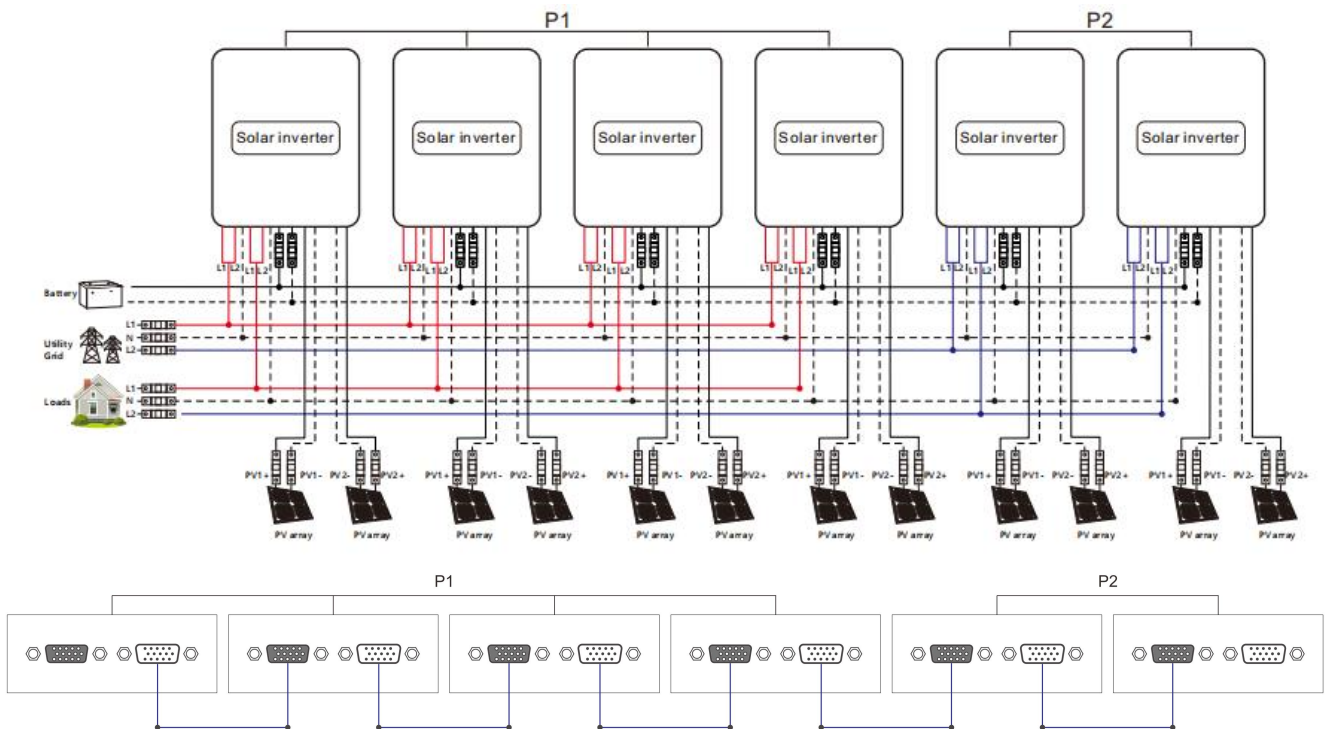

3+3 system:

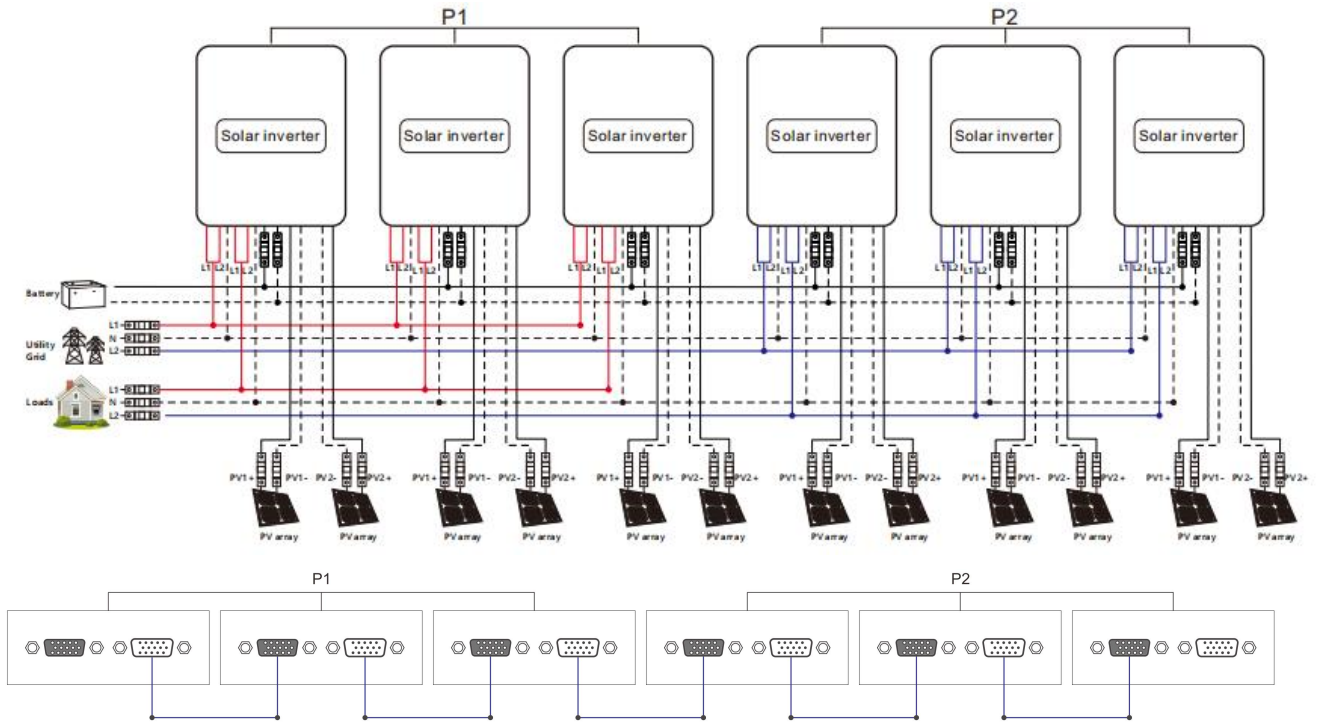

4.9.5 Wiring diagram for split-phase parallel connection (phase difference between L1 and L2: 180°)

Set the item [31] to PAL, and set the item [68] to 180°. When setting the item [38] to "120 V," the L1-L2 voltage is 240 V, and the L1-N voltage is 120 V, L2-N voltage is 120V

a. Two parallel-connected solar storage inverters:

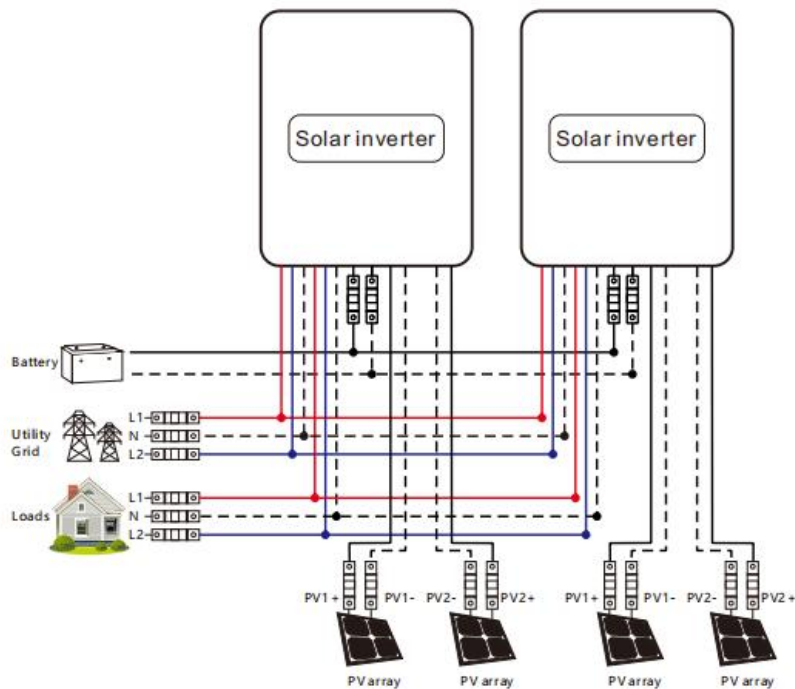

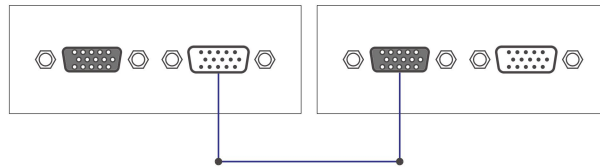

b. Three parallel-connected solar storage inverters:

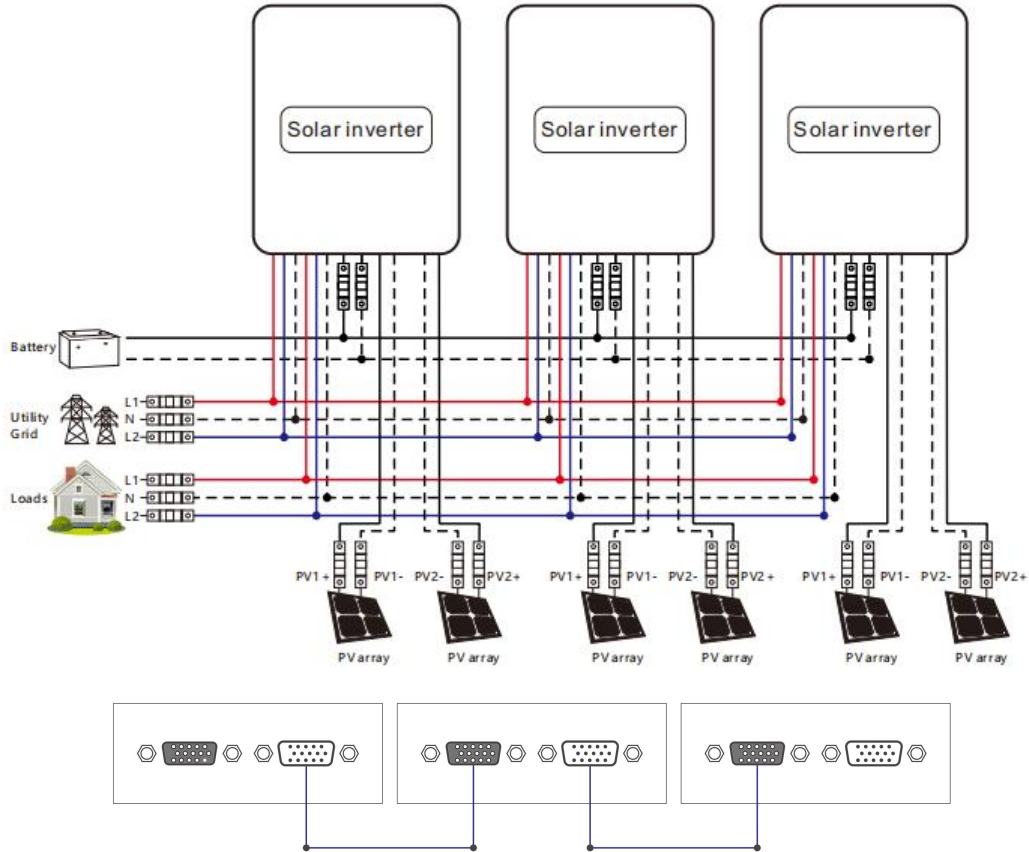

c. Four parallel-connected solar storage inverters:

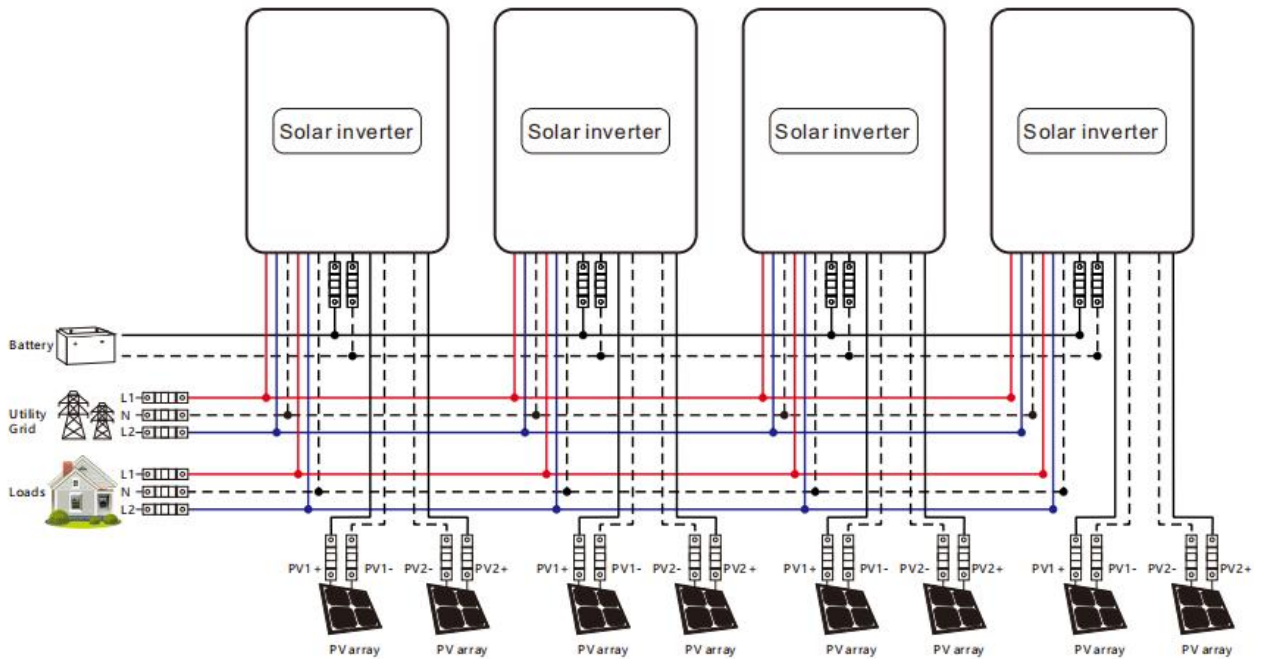

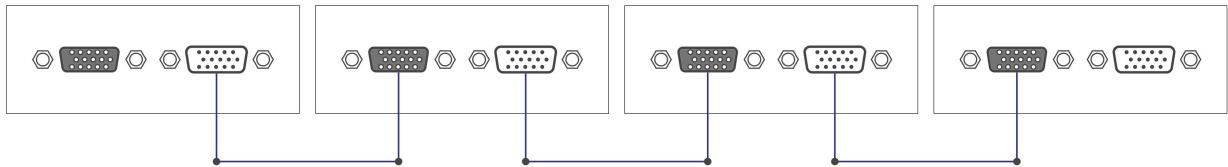

d. Five parallel-connected solar storage inverters:

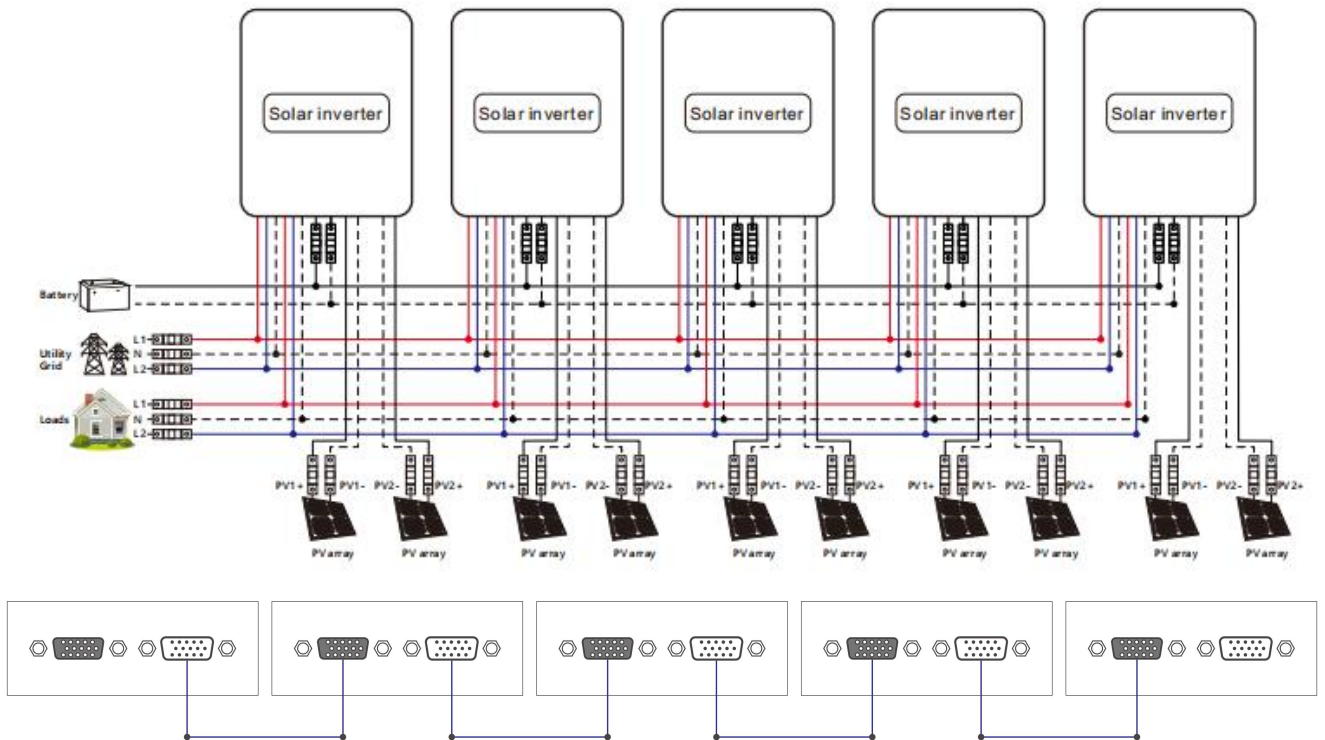

e. Six parallel-connected solar storage inverters:

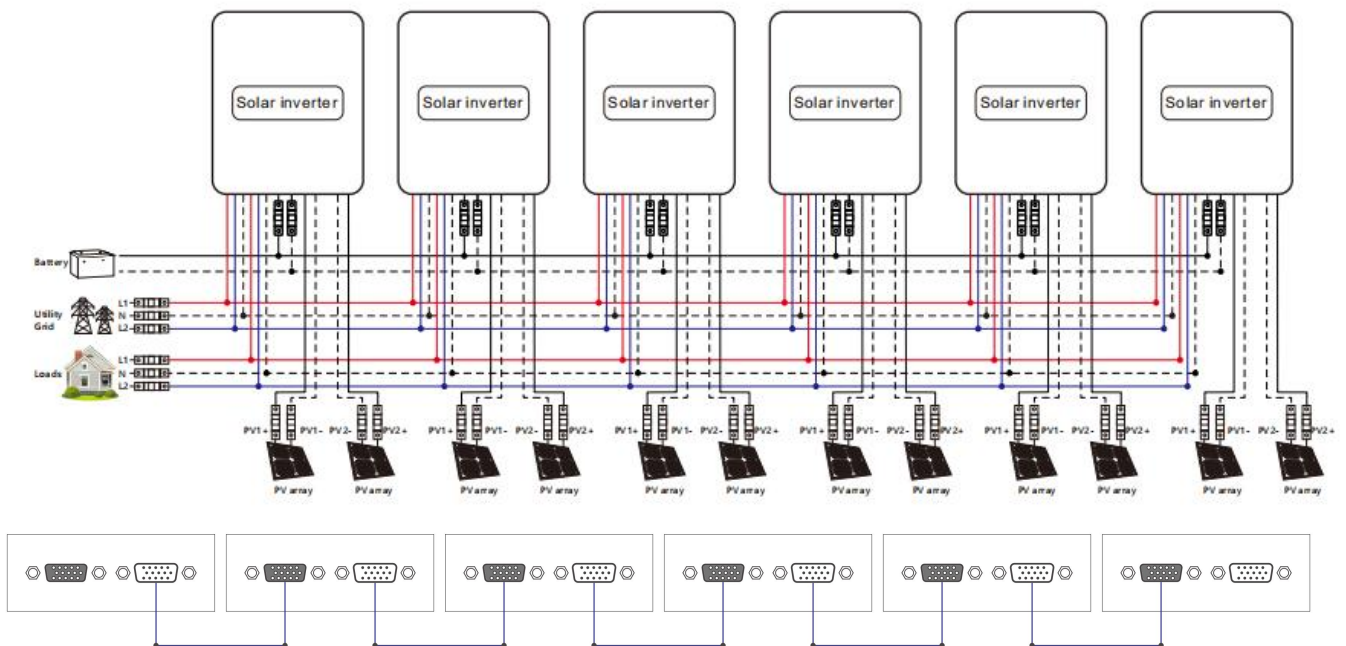

4.9.6 Wiring diagram for three-phase parallel connection

P1: Set the item [31] to "3P1;" P2: Set the item [31] to "3P2;" P3: Set the same to "3P3" , all of P1/P2/P3 inverters item [68] can not be set, it is default "0°"

At this point, the P1-P2, P1-P3, and P2-P3 phase difference is 120°. When setting the item [38] to "120 VAC," the voltage between the live wire L1 of P1 phase and the live wire L2 of P2 phase is $230 \times 1.732 = 208$ VAC. Similarly, the L1-L3 and L2-L3 voltage is 208 VAC:

a. Three-phase system (three inverters)

1+1+1 system:

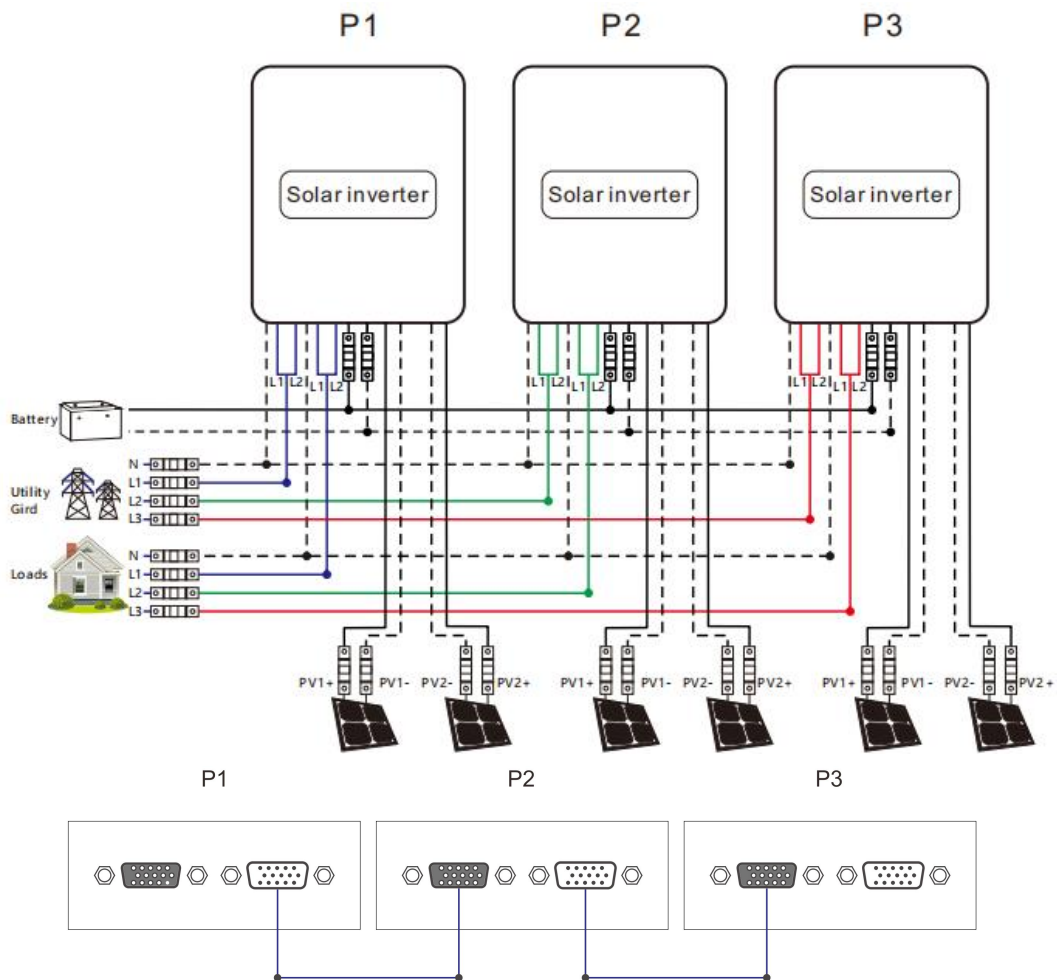

b. Three-phase system (four inverters)

2+1+1 system:

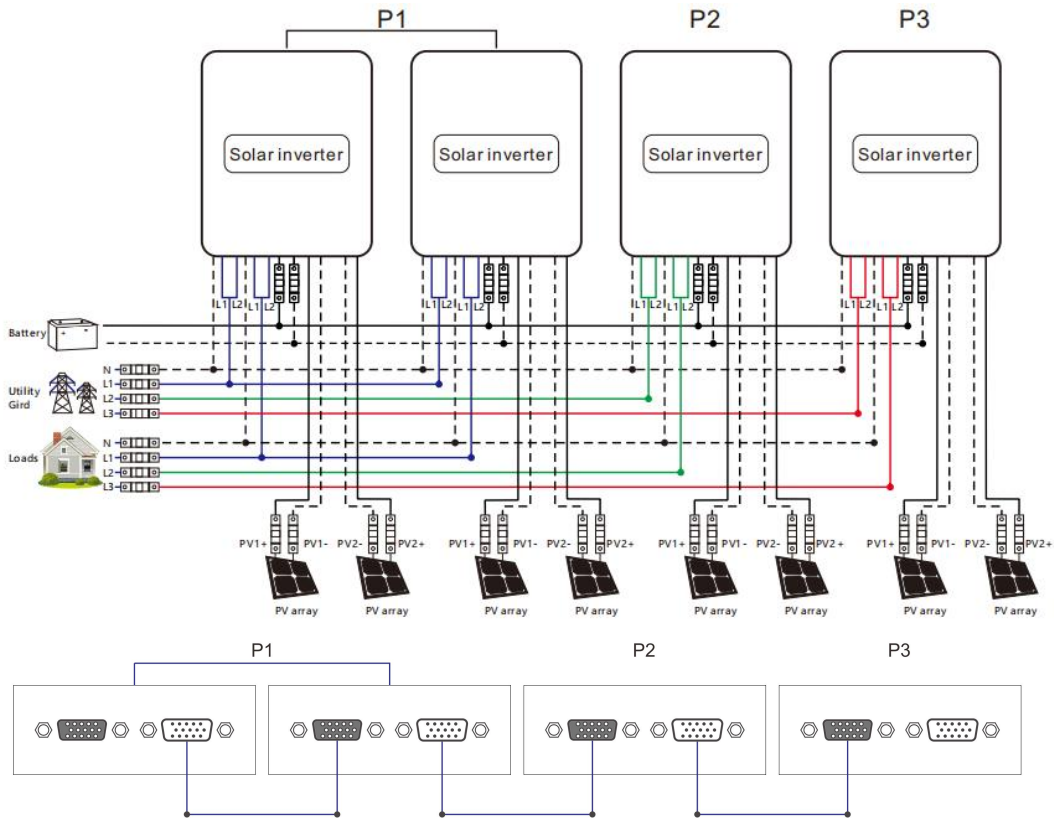

c. Three-phase system (five inverters)

3+1+1 system:

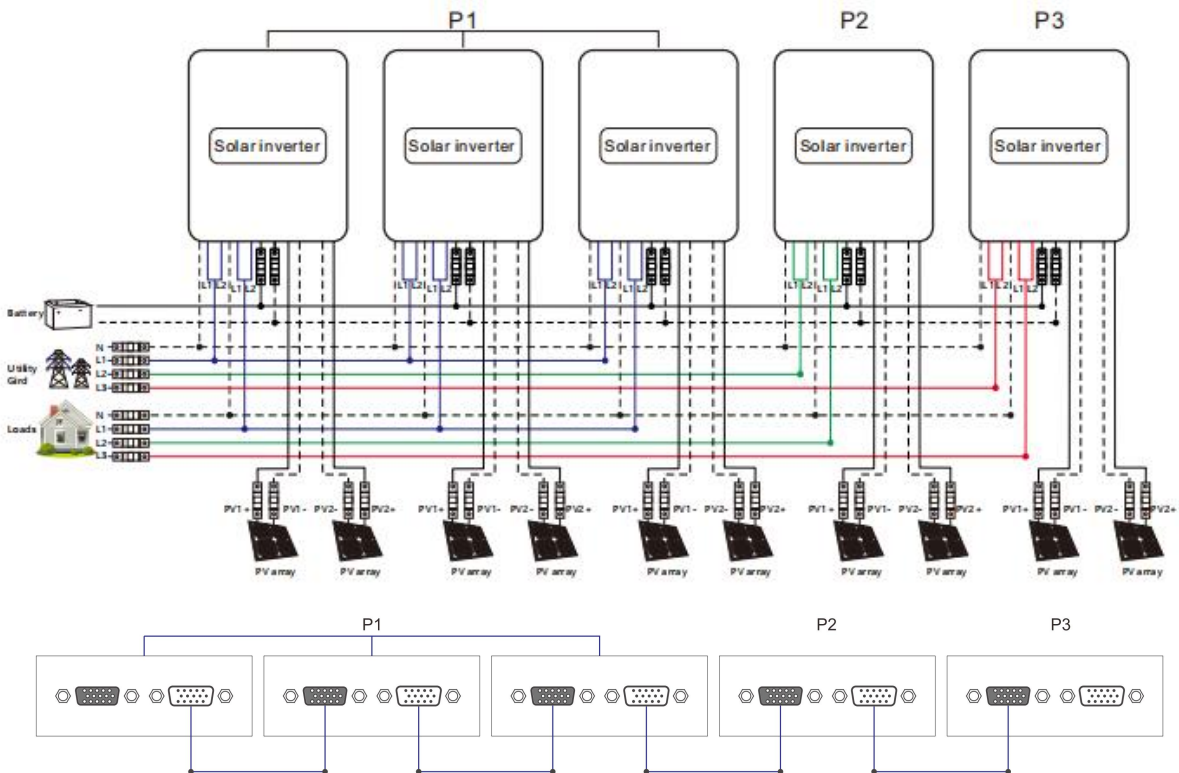

2+2+1 system:

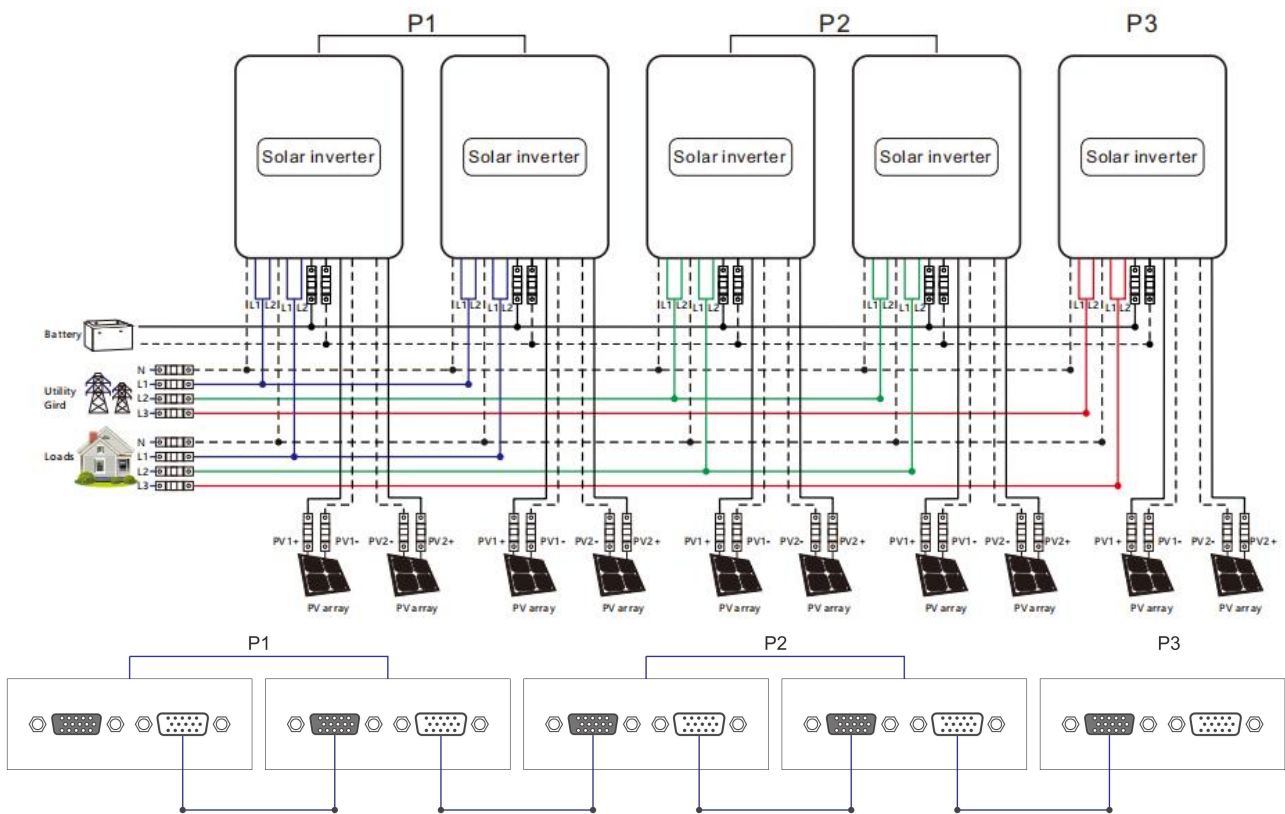

d. Three-phase system (six inverters)

2+2+2 system:

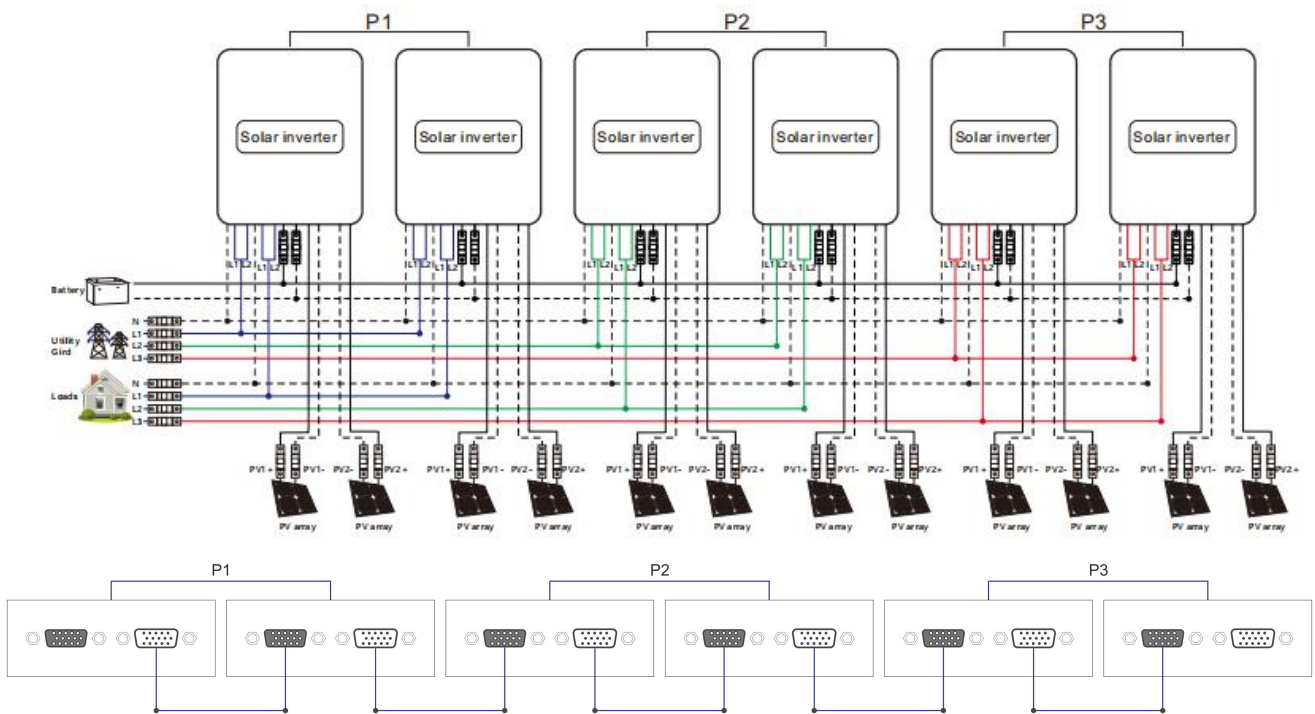

3+2+1 system:

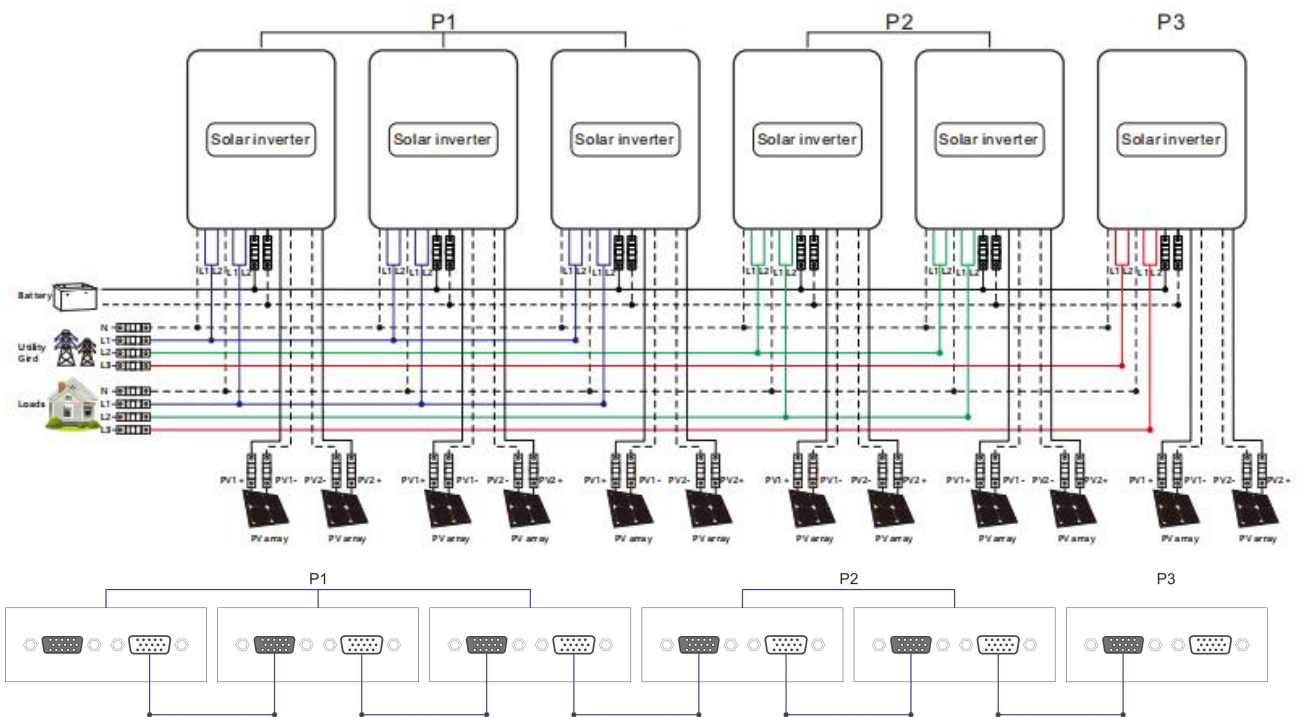

Note:

- 1) Before powering on and lighting up the screen, check for correct wiring according to the above wiring diagrams to avoid system problems.
- 2) Check all connections for firm fixing to avoid detachment and abnormal system operation.
- 3) When connecting the AC output to the load, complete wiring according to the requirements of the electrical load to avoid damage to the load.
- 3) Set the item [38] to the same parameter, or only set it in the host inverter. During parallel operation, the voltage set in the host shall prevail, so the host inverter will forcibly set the item to the value for slave inverters. Only in standby mode can the item be set.

5) The inverter defaults to single mode at the factory. If using the parallel or three-phase function, set the item [31] on the screen as follows:

Power on one inverter each time, turn off the other inverters, and then set the item [31] according to the on-site system operation mode. After setting the inverter, turn off the inverter, and set the other inverters one by one. After all are set, power on all inverters at one time to enter the working state.

In single-phase parallel operation:

Set the item [31] to "PAL" and the item [68] to "0°." When setting the item [38] to "120 V," the output L-N voltage is 120 V

In two-phase parallel operation:

(1) P1: Set the item [31] to "2P0;" P2: Set the item [31] to "2P1," all of P1/P2 inverters item [68] can not be set, it is default "0°" and the phase difference between P1 and P2 is 120°. When setting the item [38] to "120 V," the voltage between the live wire L1 of P1 phase and the live wire L2 of P2 phase is 208 V, and the L1-N voltage is 120 V

(2) P1: Set the item [31] to "2P0;" P2: Set the item [31] to "2P2," all of P1/P2 inverters item [68] can not be set, it is default "0°" and the phase difference between P1 and P2 is 180°. When setting the item [38] to "120 V," the voltage between the live wire L1 of P1 phase and the live wire L2 of P2 phase is 240 V, and the L1-N voltage is 120 V

In split-phase parallel operation:

Set the item [31] to PAL, and set the item [68] to 180°. When setting the item [38] to "120 V," the L1-L2 voltage is 240 V, and the L1-N voltage is 120 V

In three-phase parallel operation:

P1: Set the item [31] to "3P1;" P2: Set the item [31] to "3P2;" P3: Set the same to "3P3" all of P1/P2/P3 inverters item [68] can not be set, it is default "0°"

At this point, the P1-P2, P1-P3, and P2-P3 phase difference is 120°. When setting the item [38] to "120 VAC," the voltage between the live wire L1 of P1 phase and the live wire L2 of P2 phase is $120 \times 1.732 = 208$ VAC. Similarly, the L1-L3 and L2-L3 voltage is 208 VAC:

6) After the system runs, measure the correct output voltage before connecting to loads.

5. Operation

5.1 Operation and display panel

The operation and display panel of the inverter includes one LCD screen, three indicators, and four physical buttons

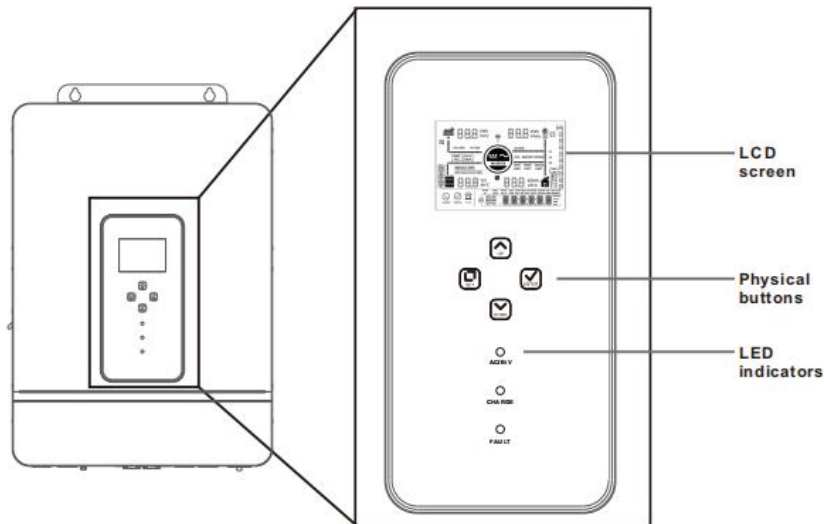

- Physical button**

Physical button	Description
	Enter/Exit the setup menu
	Go to the next option
	Go to the previous option
	Confirm/Enter the option in setup menu



- LED indicator**

Indicator	Color	Description
AC/INV	Yellow	Normally ON: mains bypass output
		Flash: inverter output
CHARGE	Green	Normally ON: charging completed
		Flash: charging
FAULT	Red	Normally ON: level-1 fault Flash: level-2 fault OFF: level-3 or level-4 fault

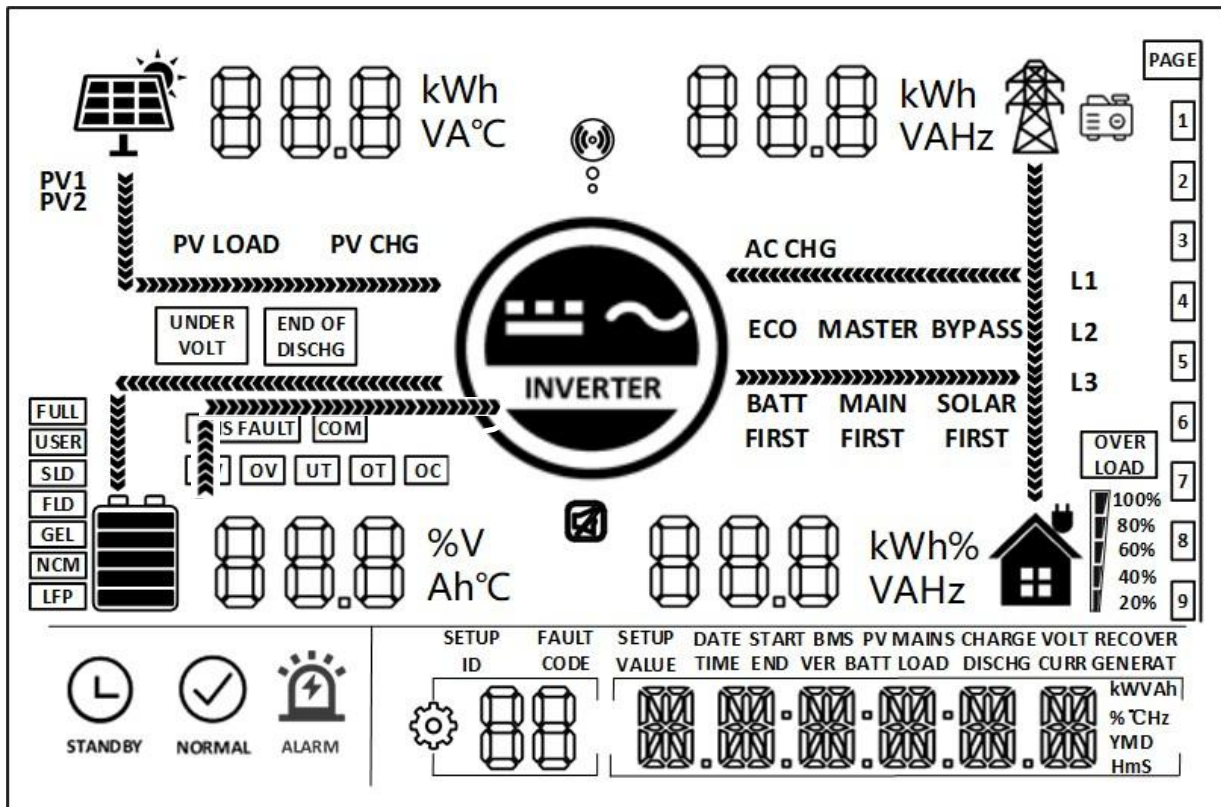
• Display screen



Icon	Description	Icon	Description
	PV panel		Mains
	Battery		Generator
	The inverter is working		Load
	The inverter is communicating with the data collector		The buzzer is in mute mode
	Power flow direction		
	The inverter is in standby mode		The inverter is working normally
	There is a fault		Settings
	Load power: 80%–100%		SOC: 80%–100%
	Load power: 60%–79%		SOC: 60%–79%
	Load power: 40%–59%		SOC: 40%–59%
	Load power: 20%–39%		SOC: 20%–39%

Icon	Description	Icon	Description
	Load power: 5%–19%		SOC: 5%–19%
UNDER VOLT	Battery under-voltage	END OF DISCHG	Battery over-discharge
OVER LOAD	Overload	BMS FAULT	BMS fault
COM	System communication error	UV	System under-voltage
OV	System overvoltage	UT	Too low system temperature
OT	Too high system temperature	OC	System overcurrent
FULL	Battery full power	USER	User-defined battery
SLD	Sealed lead-acid battery	FLD	Flooded lead-acid battery
GEL	Gel lead-acid battery	NCM	Ternary Li-ion battery
LFP	LFP Li-ion battery	ECO	Energy-saving mode
PVLOAD	PV power is loading	PVCHG	PV power is charging the battery
ACCHG	AC input power is charging the battery	MAINS FIRST	The output mode of the inverter is mains first
BYPASS	The output mode of the inverter is mains bypass	SOLAR FIRST	The output mode of the inverter is PV first
BATT FIRST	The output mode of the inverter is battery first		

• **Real-time parameters view**

On the screen, press the UP/DOWN button to view real-time data of the inverter in operation.

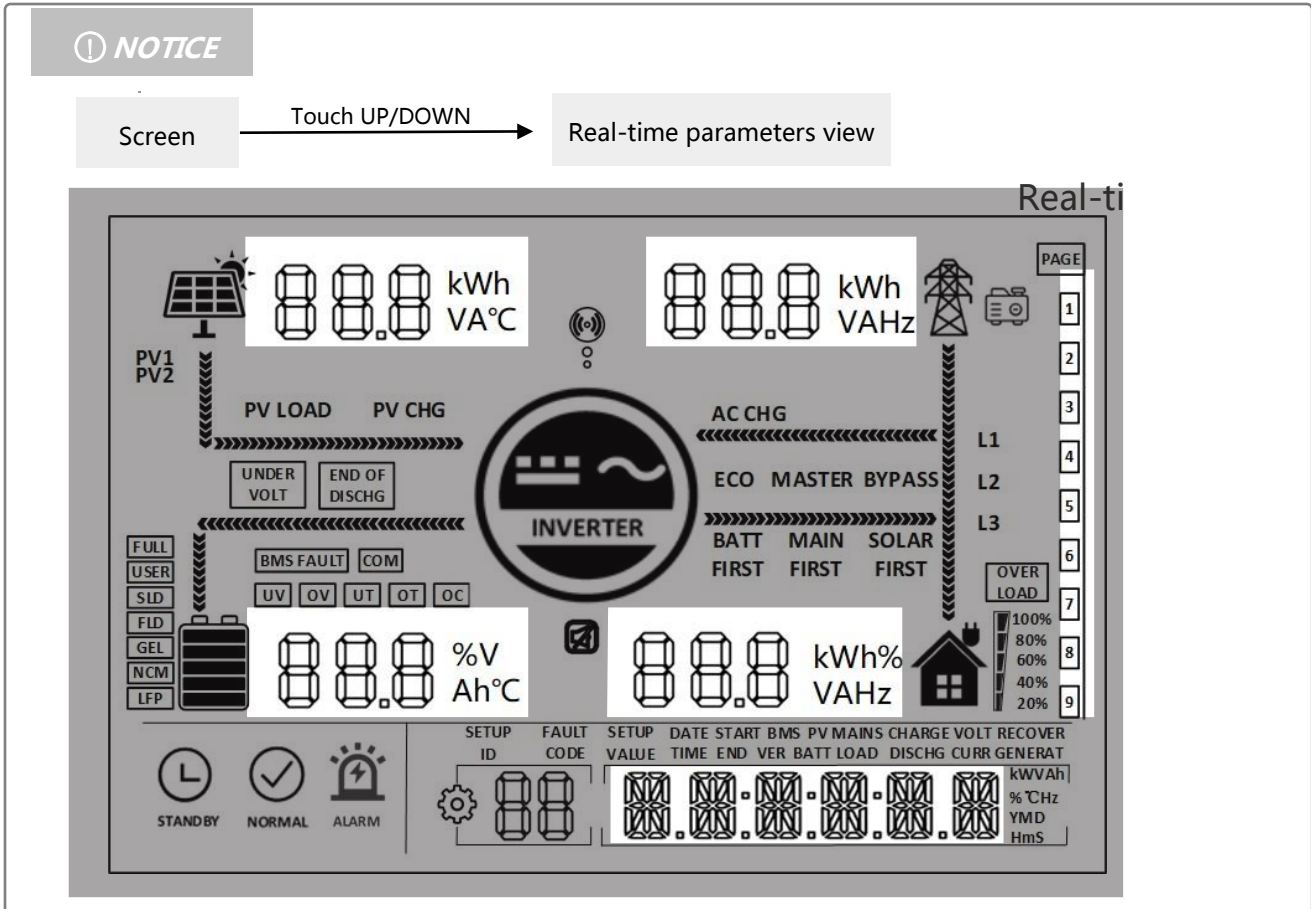

Page	PV	Battery	AC input	Load	General
1	PV input voltage	Battery voltage	Mains input voltage	Single-phase voltage	Current time
2	PV input current	Battery current	Mains input current	Single-phase current	Current date
3	PV input power	BMS Battery voltage	Mains total input power	Single-phase active power	PV gross generation
4	PV generation for the day	Battery SOC	Mains charging capacity for the day	Single-phase apparent power	Total load consumption
5	PV heat sink temperature	Heat sink temperature	Mains frequency	Inverter output frequency	RS485 address
6	Rated open circuit voltage	Rated battery voltage	Bus voltage	Rated output frequency	Software version
7	Maximum PV charge current	Maximum battery charge current	Maximum mains charge current	Total output active power	/
8			/	Total output apparent frequency	/

5.2 Setting

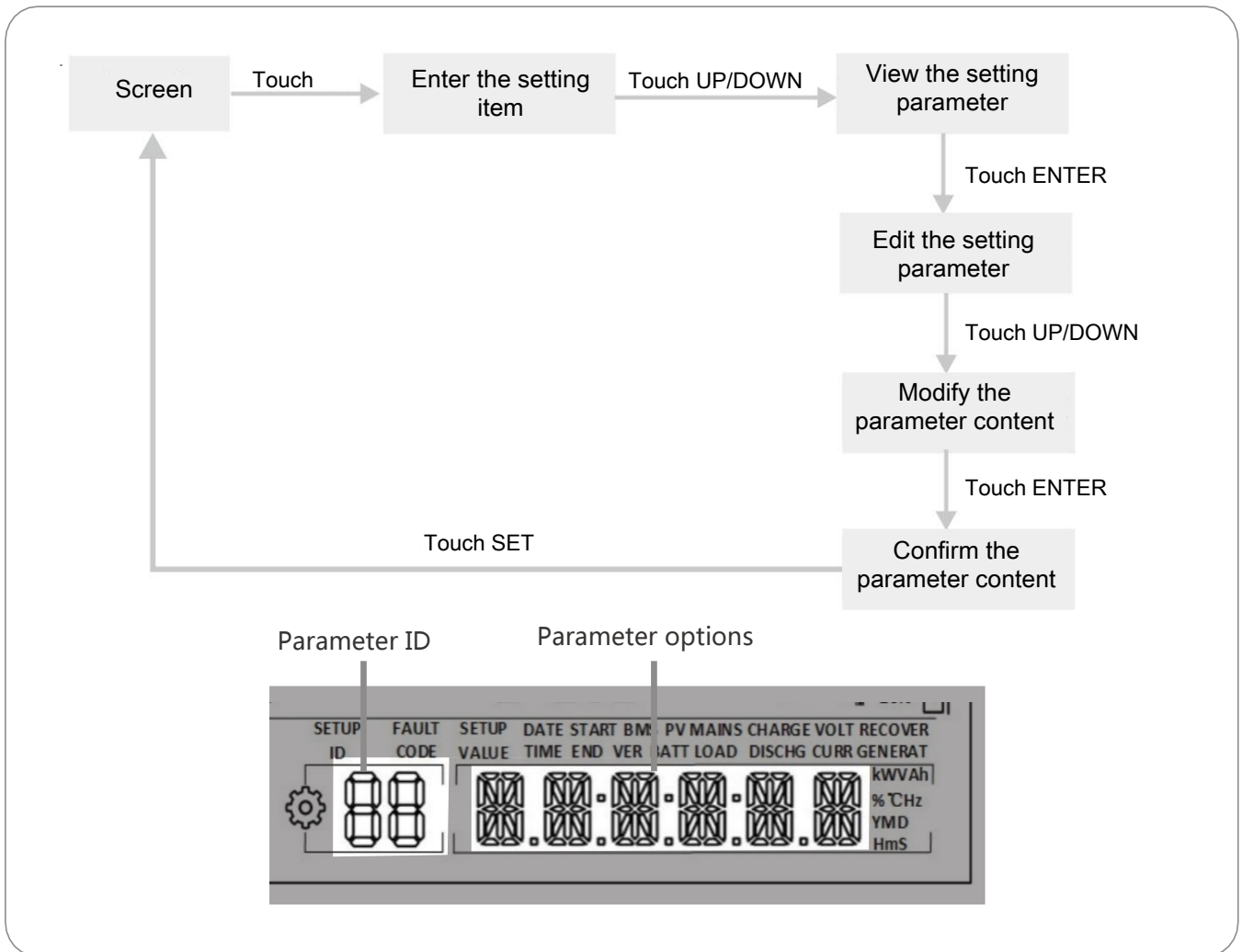

ID	Parameter	Option	Description
The voltage setting logic: 【15】 < 【12】 < 【04】 < 【14】 < 【35】 < 【37】 < 【05】 < 【09/11】			
00	Exit	ESC	Exit the setup menu
01	AC output mode	UTI	Photovoltaic energy priority with the load, photovoltaic is not enough, the grid power and photovoltaic mixed load, photovoltaic energy is enough with the load, the excess energy to charge the battery, the grid power only starts charging when the battery is too discharged (06 Settings as "OSO(only PV)", the grid power will not charge), the battery is only discharged when off the grid.
		SBU	Inverter first. The PV mode is to be applied first for loading, and only when the battery voltage is lower than the set value in the item 4, it will switch to the mains mode for loading. When the battery voltage is higher than the set value in the item 5, it will

ID	Parameter	Option	Description
			switch back to the PV mode from the mains mode.
		SOL	The PV mode is to be applied first and when the PV power is unavailable or the battery voltage is lower than the set value in the item 4, it will switch to the mains mode
		SUB(default)	Solar energy priority charging, insufficient solar energy, grid energy and solar energy hybrid charging (if 06 Settings as "OSO(only PV) ", the grid energy will not charge) and grid with load, when solar energy is enough to charge, excess energy not enough to load, excess solar energy and grid will hybrid load, the battery is discharged only when off the grid.
02	AC input frequency	50.0	In bypass mode, the AC output frequency will adapt to the mains frequency, and in other cases, the output will follow the preset value.
		60.0 (default)	
03	AC input voltage range	UPS (default)	When the output voltage is 120/110 V, the input voltage range is 90 V–140 V
		APL	When the output voltage is 100/105 V, the input voltage range is 85 V–140 V
04	Battery to mains voltage threshold	43.6 (default)	When the parameter item 01 is SBU or SOL and the battery voltage is lower than the threshold, the output switches from inverter to mains. Setting range: 40 V–52 V
05	Mains to battery voltage threshold	57.6 (default)	When the parameter item 01 is SBU or SOL and the battery voltage is higher than the threshold, the output switches from mains to inverter. Setting range: 48 V–60 V
06	Battery charge mode	SNU (default)	When both PV power and mains are used to charge the battery at one time, the PV charge first and when the PV power is insufficient, the mains tags in. Only in bypass mode can both PV power and mains be used to charge the battery at one time, and only the PV charge mode can be enabled during inverter operation.
		OSO	Do not enable the mains charge mode when in only PV charge mode.
07	Battery charge current	60	SPH8048P, setting range: 0 A–180 A This setting should be greater than 28 items. Item 07 is the maximum charging current for battery charging with "PV and GRID" or "Generator + Utility" ; If the 28 item setup item and 73 item setup item are greater than the 07 item setup item, they do not have an effect.
			SPH10048P, setting range: 0 A–200 A
08	Battery type	USER	User-defined, and in this type, you can set all battery parameters

ID	Parameter	Option	Description
		SLD	Sealed lead-acid battery
		FLD	Flooded lead-acid battery
		GEL (default)	Gel lead-acid battery
		L14/L15/L16	LFP battery L14/L15/L16, corresponding to 14, 15, and 16 series of LFP batteries
		N13/N14	Ternary Li-ion battery N13/N14, corresponding to 13 and 14 series of ternary Li-ion batteries
		NOb	No battery
09	Battery boost charge voltage	57.6	Setting range: 48 V–58.4 V, with a step of 0.4 V, available for user-defined and lithium-ion battery types
10	Boost charge duration	120	The continuous charging time when the voltage reaches the set voltage during constant voltage charging, with a setting range of 5 min–900 min and a step of 5 min
11	Battery floating charge voltage	55.2	Setting range: 48 V–58.4 V, with a step of 0.4 V. This parameter cannot be set after successful BMS communication
12	Battery over-discharge voltage (delayed shutdown)	42	When the battery voltage is lower than the voltage and triggers the set value in the item 13, it will turn off the inverter output. Setting range: 40 V–48 V, with a step of 0.4 V
13	Battery over-discharge delay time	5	When the battery voltage is lower than the set value in the item 12 and triggers the delay time set in this parameter item, it will turn off the inverter output. Setting range: 5s–50s, with a step of 5s
14	Battery under-voltage alarm threshold	44	When the battery voltage is lower than the threshold, it will give an under-voltage alarm and the output will not shut down. Setting range: 40 V–52 V, with a step of 0.4 V
15	Battery discharge limit voltage	40	When the battery voltage is lower than the value, the output immediately shuts down. Setting range: 40 V–52 V, with a step of 0.4 V, available for user-defined and Li-ion batteries
16	Battery equalizing charge	DIS	Disable equalizing charge
		ENA (default)	Enable equalizing charge, but only available for flooded lead-acid batteries, sealed lead-acid batteries, and user-defined ones
17	Equalizing charge voltage	58	Setting range: 48 V–58 V, with a step of 0.4 V, but only available for flooded lead-acid batteries, sealed lead-acid batteries, and user-defined ones
18	Equalizing charge	120	Setting range: 5 min–900 min, with a step of 5 min, but only

ID	Parameter	Option	Description
	duration		available for flooded lead-acid batteries, sealed lead-acid batteries, and user-defined ones
19	Equalizing charge delay time	120	Setting range: 5 min–900 min, with a step of 5 min, but only available for flooded lead-acid batteries, sealed lead-acid batteries, and user-defined ones
20	Equalizing charge interval	30	Setting range: 0 day–30 days, with a step of 1 day, but only available for flooded lead-acid batteries, sealed lead-acid batteries, and user-defined ones
21	Equalizing charge Enable/Disable	DIS (default)	Start equalizing charge immediately
		ENA	Stop equalizing charge immediately
22	Energy-saving mode	DIS (default)	Disable energy-saving mode
		ENA	Enable energy-saving mode, and when the load power is below 50 W, it will turn off the inverter output after a 5-minute delay. When it exceeds 50 W, the inverter will automatically restart.
23	Overload auto restart	DIS	Disable overload auto restart and when overload occurs, it will turn off the output and the inverter will no longer resume startup
		ENA (default)	Enable overload auto restart, and If overload occurs, the output will be turned off, and after a delay of 3 min, the output will restart. After 5 cumulative attempts, the inverter will no longer resume startup
24	Over-temperature auto restart	DIS	Disable over-temperature auto restart and when over-temperature occurs, it will turn off the output and the inverter will no longer turn on the output
		ENA (default)	Enable over-temperature auto restart and when over-temperature occurs, it will turn off the output and the output will restart when the temperature drops
25	Buzzer alarm	DIS	Disable buzzer alarm
		ENA (default)	Enable buzzer alarm
26	Mode switch prompt	DIS	Disable prompt when the status of the main input source changes
		ENA (default)	Enable prompt when the status of the main input source changes
27	Inverter to bypass switch	DIS	Disable auto switch to mains for loading in case of inverter overload
		ENA (default)	Enable auto switch to mains for loading in case of inverter overload
28	Mains charge	60 (default)	SPH8048P, setting range: 0 A–100 A

ID	Parameter	Option	Description
	current		SPH10048P, setting range: 0 A–120 A
30	RS485 communication address	ID: 1	Setting range: 1–254
31	Parallel mode (turn off the rocker switch can be set)	SIG (default)	Single inverter operation
		PAL	Parallel operation
		2P0/2P1/2P2	Two-phase parallel operation
		Set to "2P0" for the machine screens connected to P1 Assuming that the output voltage of the setting item [38] is set to 120 VAC 1) When all the inverters connected to P2 are set to "2P1" on the screen, the voltage phase difference between P1 and P2 is 120°, the voltage between the live wire L1 of phase-P1 and the live wire L2 of phase-P2 is $120 \times 1.732 = 208$ VAC, and the voltage of L1-N and L2-N is 120 VAC. 2) When all the inverters connected to P2 are set to "2P2" on the screen, the voltage phase difference between P1 and P2 is 180°, the voltage between the live wire L1 of phase-P1 and the live wire L2 of phase-P2 is $120 \times 2 = 240$ VAC, and the voltage of L1-N and L2-N is 120 VAC.	
		3P1/3P2/3P3	Three-phase parallel operation
		Set to "3P1" on the screen for all the inverters connected to P1; set to "3P2" on the screen for all the inverters connected to P2; and set to "3P3" on the screen for those connected to P3. 1) Assuming that the output voltage of the setting item [38] is set to 120 VAC: then the voltage phase difference of P1-P2, P1-P3, and P2-P3 is 120°, the voltage between the live wire L1 of phase-P1 and the live wire L2 of phase-P2 is $120 \times 1.732 = 208$ VAC, and similarly the voltage of L1-L3 and L2-L3 is 208 VAC; the voltage of L1-N, L2-N, and L3-N is 120 VAC.	
32	RS485 communication function	SLA (default)	Enable PC and Remote Monitoring Protocol
		485	Enable the BMS communication function based on RS485 communication
		CAN	Enable the BMS communication function based on CAN communication
33	BMS communication	Select the corresponding communication protocol in item 33 when you set it to 485 or CAN in item 32	
		SGP=SUNGOLDPOWER ,PAC=PACE ,RDA=Ritar ,AOG=ALLGRANDBATTERY ,OLT=OLITER , XWD=SUNWODA, DAQ=DAKING, WOW=SNPOWER, PYL=PYLONTECH , DYE=DEYE , LUX=LUXPOWER	
35	Battery under-voltage	52	When the battery is under voltage, the battery voltage needs to be greater than the threshold to restore the AC output of the

ID	Parameter	Option	Description
	recovery threshold		battery inverter. Setting range: 44 V–54.4 V
37	Recharge voltage threshold for fully charged battery	52	After the battery is fully charged, the inverter stops charging, and recovers charging when the battery voltage is lower than the threshold. Setting range: 44 V–54 V
38	AC output voltage (turn off the rocker switch can be set)	120	Setting range: 100/105/110/115/120/127 VAC The rated output power will be reduced= (Power Rate)*(Vset/120)
39	Charge current limit (when BMS works)	LCSET	The maximum battery charge current is not greater than the set value of [item 07]
		LCBMS (default)	The maximum battery charge current is not greater than the maximum value of BMS
		LCINV	The maximum battery charge current is not greater than the logical judgment value of inverter
40	Period-1 battery charge start time	00:00:00	Setting range: 00:00:00–23:59:00
41	Period-1 battery charge end time	00:00:00	Setting range: 00:00:00–23:59:00
42	Period-2 battery charge start time	00:00:00	Setting range: 00:00:00–23:59:00
43	Period-2 battery charge end time	00:00:00	Setting range: 00:00:00–23:59:00
44	Period-3 battery charge start time	00:00:00	Setting range: 00:00:00–23:59:00
45	Period-3 battery charge end time	00:00:00	Setting range: 00:00:00–23:59:00
46	Timed battery charge function	DIS (default)	Disable the function
		ENA	After the timed mains charge/loading function is enabled, the power supply mode will turn into SBU, where mains is available for power supply in the set period or after battery over-discharge. If the timed discharge function is enabled at the same time, the power supply mode of the system will be changed into UTI, where mains is only available for power supply in the set charge period, and the system only switches to the power supply of battery inverter during the set discharge period or mains failure
47	Period-1 battery discharge start time	00:00:00	Setting range: 00:00:00–23:59:00

ID	Parameter	Option	Description
48	Period-1 battery discharge end time	00:00:00	Setting range: 00:00:00–23:59:00
49	Period-2 battery discharge start time	00:00:00	Setting range: 00:00:00–23:59:00
50	Period-2 battery discharge end time	00:00:00	Setting range: 00:00:00–23:59:00
51	Period-3 battery discharge start time	00:00:00	Setting range: 00:00:00–23:59:00
52	Period-3 battery discharge end time	00:00:00	Setting range: 00:00:00–23:59:00
53	Timed battery discharge function	DIS (default)	Disable the function
		ENA	After the timed battery discharge function is enabled, the power supply mode will be changed into UTI, where the system only switches to the power supply of battery inverter during the set discharge period or mains failure
54	Current date	00:00:00	Year/Month/Day Setting range: 00:01:01–99:12:31
55	Current time	00:00:00	Setting range: 00:00:00–23:59:59
57	Charge stop current	3	The charge stops when the charge current is less than the set value (unit: A)
58	SOC setting for discharge alarming	15	When the capacity is less than the set value, the SOC alarms (unit: %, only available during normal BMS communication)
59	SOC setting for discharge cutoff	5	When the capacity is less than the set value, the discharge stops (unit: %, only available during normal BMS communication)
60	SOC setting for charge cutoff	100	When the capacity is greater than the set value, the charge stops (unit: %, only valid during normal BMS communication)
61	SOC setting for switching to mains	10	When the capacity is less than the set value, it switches to mains (unit: %, only available during normal BMS communication)
62	SOC setting for switching to inverter output	100	When the capacity is greater than the set value, it switches to the inverter output mode (unit: %, only available during normal BMS communication)

ID	Parameter	Option	Description
63	Auto N-PE connection switch function	DIS (default)	Disable auto N-PE connection switch
		ENA	Enable auto N-PE connection switch
68	AC output phase mode (turn off the rocker switch can be set)	0	0 represents the single-phase mode Assuming that the AC output voltage of item 38 is 120 V, the phase difference of L1-L2 is 0°, and L1/L2 can be connected in parallel, the phase voltage of L1-N/L2-N is 120 V
		180 (default)	180 represents the split-phase mode Assuming that the AC output voltage of item 38 is 120 V, the phase difference of L1-L2 is 180°, the phase voltage of L1-N/L2-N is 120 V, and the voltage of L1-L2 is 240 V
		NO N	Without N-wire(When you set" No N" ,the phase difference is 180° default)

5.3 AC output mode

The AC output mode corresponds to parameter setting items of 01, allowing users' manual setting

- Mains first 01 UTI**

The mains first supplies power. When PV is available, mains and PV can supply power to the load at the same time. The battery only powers the load during unavailable mains (**priority: mains > PV > battery**).

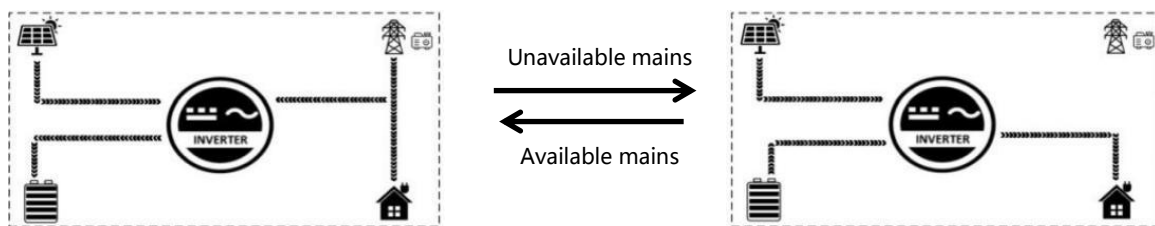

- Mix loading of PV and mains**

In the UTI mode, when the battery is not connected, or fully charged, PV and mains supply power to the load at the same time (**priority: PV > mains > battery**).



- Inverter output mode 01 SBU**

PV will first supply power to the load. If PV power is insufficient or unavailable, mains will be used as a supplement to power the load. When the battery voltage reaches the value of the parameter item 04 (battery to mains voltage threshold), it will switch to mains to power the load. The mode maximizes the use of DC power, suitable for areas with suitable power grids. **(Priority: PV > battery > mains)**.

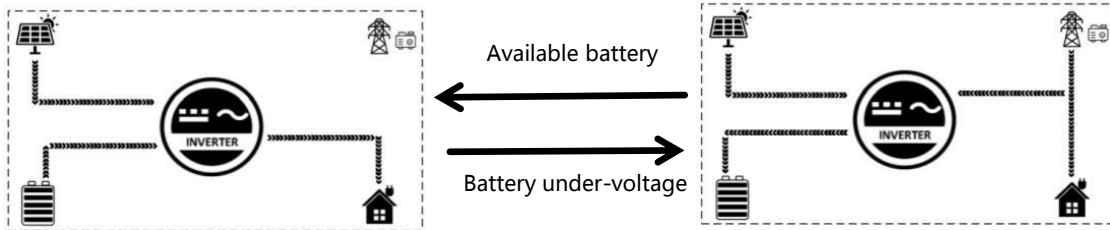

● **PV-first output 01 SOL**

PV first supplies power to the load. If PV power is insufficient, mains is used as a supplement to power the load. The mode uses PV power to the maximum extent while maintaining the battery power, suitable for areas with relatively stable power grids. **(Priority: PV > mains > battery)**.

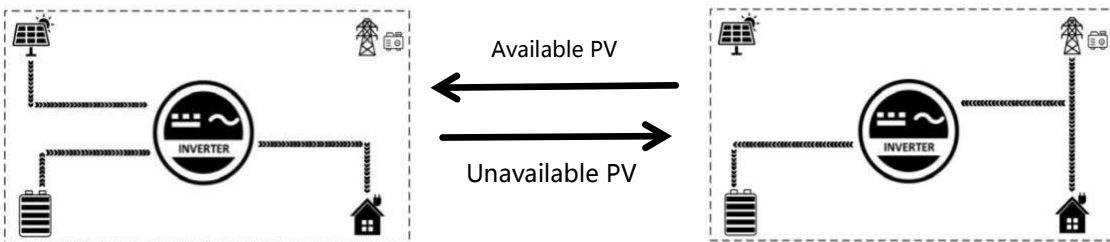

● **Mixed load output mode 01 SUB (default)**

(Solar priority charging, when solar energy is not enough to charge the battery, grid and solar energy will mix to charge the battery (if 06 setting item is set to "OSO (only PV)" , then grid will not charge);

When solar energy is enough to charge, excess energy can be used to carry the load. If the remaining solar energy is not enough to carry the load, the excess solar energy and the grid will be mixed to carry the load;

When there is no grid, the battery will only participate in carrying the load.

PV Priority: Charge > Load ; Carrying Load Priority: Mains > PV > Battery)

SUB mode can be used as a back-up energy storage, with fast charging speed, and is suitable to be applied in unstable areas of the power grid.

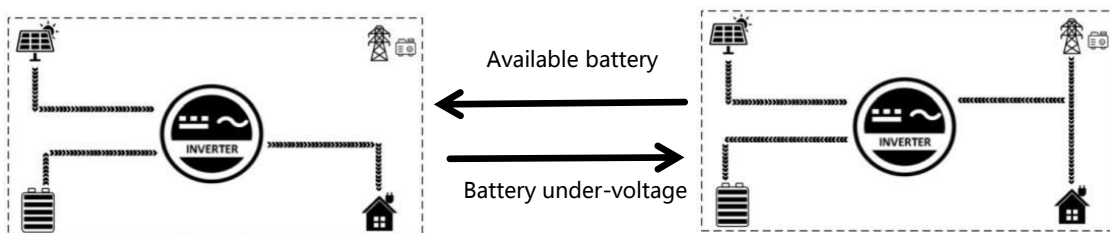

5.4 Battery charge mode

The charge mode corresponds to the parameter setting item 06, allowing users' manual setting.

- **Mix charge SNU (default)**

Both PV and mains charge the battery, with PV used first, and mains as a supplement during insufficient PV power. This is the fastest charge method, suitable to provide users with sufficient backup power in areas where the power supply is insufficient. (**Priority: PV > mains**).

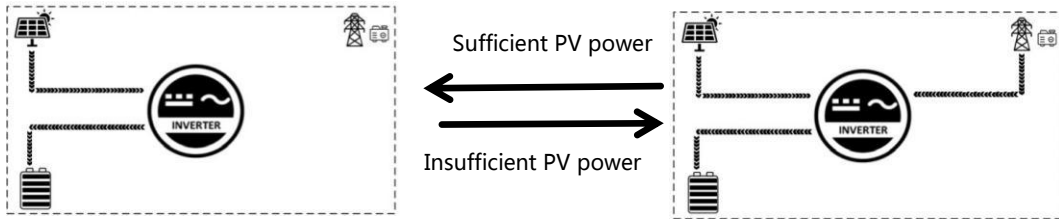

- **Only-PV charge OSO**

Only PV power is used to charge the battery, with mains not used for charge. This is the most energy-saving method, by which the battery power comes from solar energy, usually used in areas with good radiation conditions.

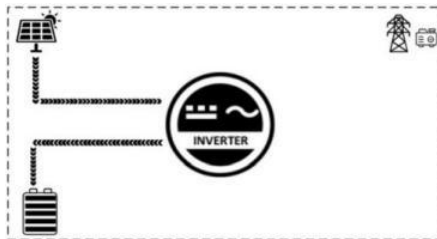

5.5 Timed charge/discharge function

SPH U series has the timed power charge/discharge function. Users can set different charge and discharge periods according to the local time-of-use price, thus reasonably using mains and PV power. When mains is expensive, the battery inverter is used to supply power to the load; when mains is cheap, it can be used to supply power to and charge the load, thus helping users reduce electricity expenses to the full extent. Users can turn on/off the timed charge/discharge function in items 46 and 53 in the setup menu, and set charge and discharge periods in parameters 40–45 and 47–52.

The following is an example to help users understand the function.

Before using the function for the first time, please set the local time and date in parameters 54 and 55, and then you can set corresponding periods based on the local time-of-use price.

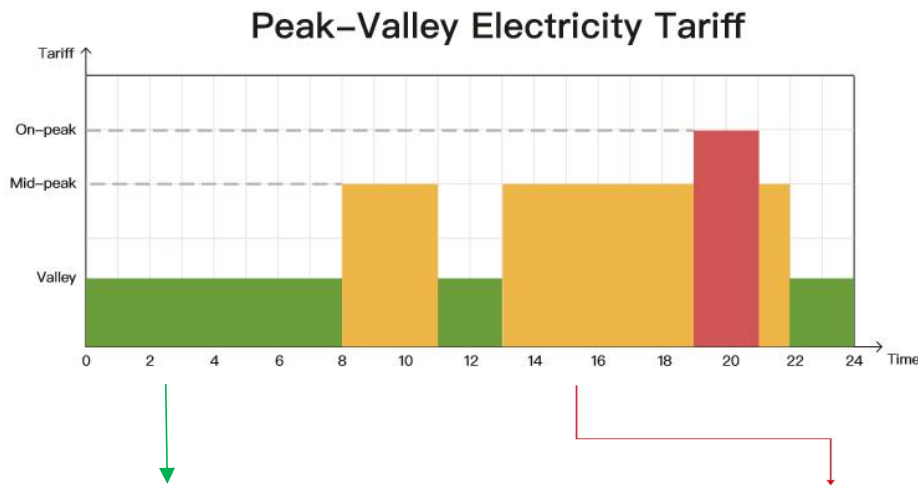

Timed charge and loading function



With 3 definable periods, users can freely set the mains charge/loading period in the range of 00:00–23:59. During the period set by the user, in case of PV energy output, it will be used first; in case of no PV energy output or lack of PV energy, mains will be used as a supplement.

Timed battery discharge function



With 3 definable periods, users can freely set the battery discharge period in the range of 00:00–23:59. During the period set by the user, the inverter will first use the battery inverter to load; if the battery power is insufficient, the inverter will automatically switch to mains to ensure stable operation of the load.

5.6 Battery parameters

- Lead-acid battery

Parameter/Battery Type	Sealed Lead-acid Battery	Gel lead-acid battery	Flooded Lead-acid Battery	User-defined Battery
	SLD	GEL	FLD	USE
Overvoltage disconnect voltage	60 V	60 V	60 V	60 V
Equalizing charge voltage	58 V	56.8 V	58 V	40 V–60 V (settable)
Boost charge voltage	57.6 V	56.8 V	57.6 V	40 V–60 V (settable)
Floating charge voltage	55.2 V	55.2 V	55.2 V	40 V–60 V (settable)
Under-voltage alarm voltage	44 V	44 V	44 V	40 V–60 V (settable)
Under-voltage disconnect voltage	42 V	42 V	42 V	40 V–60 V (settable)
Discharge limit voltage	40 V	40 V	40 V	40 V–60 V (settable)
Over-discharge delay time	5s	5s	5s	1s–30s (settable)
Equalizing charge duration	120 min	-	120 min	0 min–900 min (settable)
Equalizing charge cycle	30 d	-	30 d	0 d–250 d (settable)
Boost charge cycle	120 min	120 min	120 min	10 min–900 min (settable)

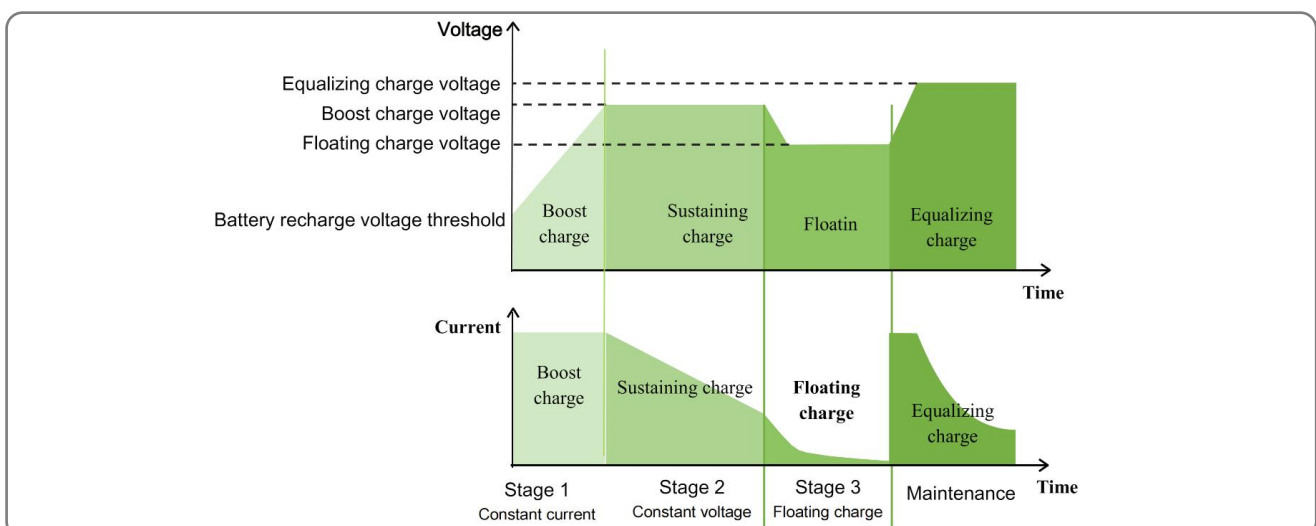

- **Li-ion battery**

Parameter/Battery Type	Ternary Li-ion Battery		LFP Battery			User-defined Battery
	N13	N14	L16	L15	L14	USE
Overvoltage disconnect voltage	60 V	60 V	60 V	60 V	60 V	60 V
Equalizing charge voltage	-	-	-	-	-	40 V–60 V (settable)
Boost charge voltage	53.2 V	57.6 V	56.8 V	53.2 V	49.2 V	40 V–60 V (settable)
Floating charge voltage	53.2 V	57.6 V	56.8 V	53.2 V	49.2 V	40 V–60 V (settable)
Under-voltage alarm voltage	43.6 V	46.8 V	49.6 V	46.4 V	43.2 V	40 V–60 V (settable)
Under-voltage disconnect voltage	38.8 V	42 V	48.8 V	45.6 V	42 V	40 V–60 V (settable)
Discharge limit voltage	36.4 V	39.2 V	46.4 V	43.6 V	40.8 V	40 V–60 V (settable)
Over-discharge delay time	30s	30s	30s	30s	30s	1s–30s (settable)
Equalizing charge duration	-	-	-	-	-	0 min–900 min (settable)
Equalizing charge cycle	-	-	-	-	-	0 d–250 d (settable)
Boost charge cycle	120 min (settable)	120 min (settable)	120 min (settable)	120 min (settable)	120 min (settable)	10 min–900 min (settable)

6. Communication

6.1 Overview

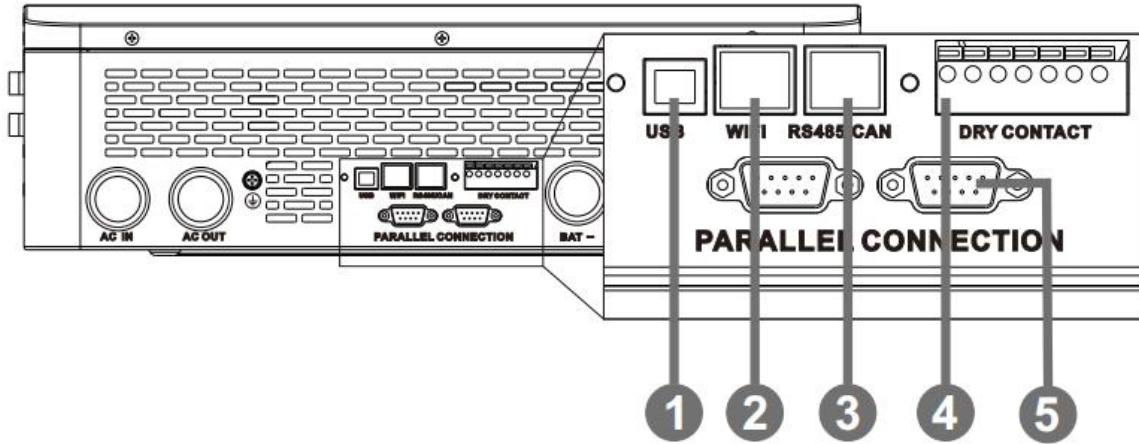

1	USB-B port	2	WIFI port	3	RS485/CAN port
4	Dry contact port	5	Parallel port		

6.2 USB-B port

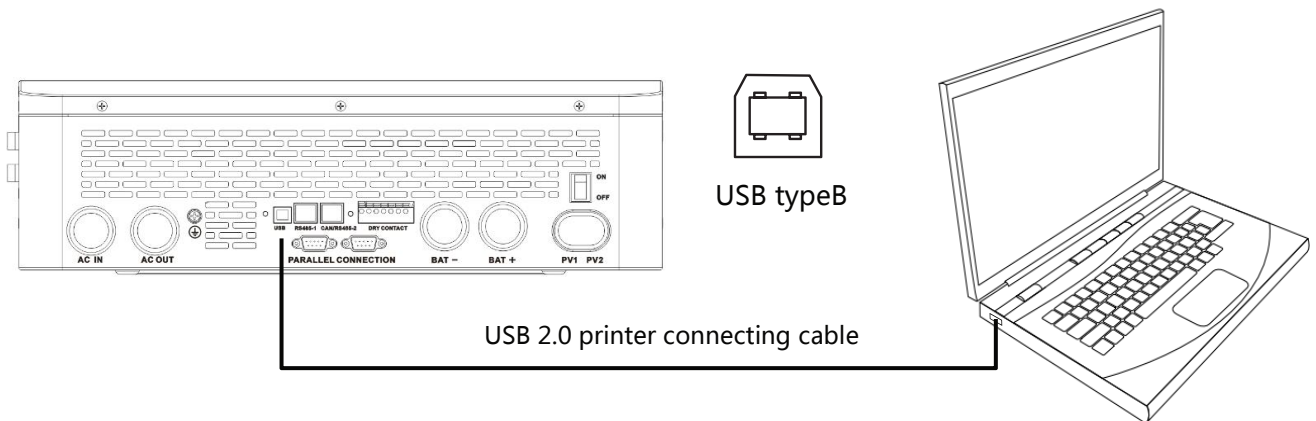

Users can use the upper computer software through the port to read and modify device parameters. If needing the installation package for the upper computer software, you can contact us to get it.

6.3 WIFI port

The WIFI port is used to connect to the Wi-Fi/GPRS data acquisition module, and then users can view the operation status and parameters of the inverter via the mobile APP.

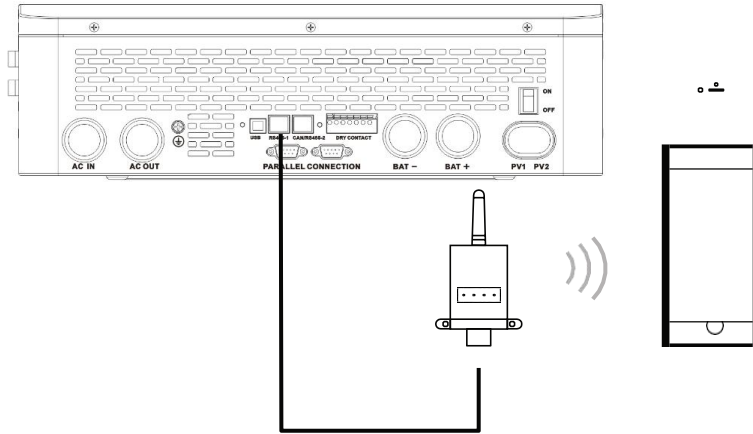

RJ45	Definition
Pin 1	5 V
Pin 2	GND
Pin 3	/
Pin 4	/
Pin 5	/
Pin 6	/
Pin 7	RS485-A
Pin 8	RS485-B

6.4 RS485/CAN port

The RS485/CAN port is used to connect to the BMS of the Li-ion battery.

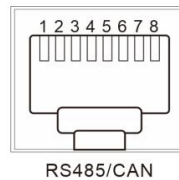

NOTICE

If you need the communication between the inverter and the BMS of the Li-ion battery, please contact us to understand the communication protocol, or upgrade the inverter to the corresponding software program.

RJ45	Definition
Pin 1	RS485-B
Pin 2	RS485-A
Pin 3	/
Pin 4	CANH
Pin 5	CANL
Pin 6	/
Pin 7	RS485-A
Pin 8	RS485-B

6.5 Dry contact port

The dry contact port has 4 functions:

1. Remote ON/OFF
2. ON/OFF signal output
3. Battery temperature sampling
4. Remote generator start/stop

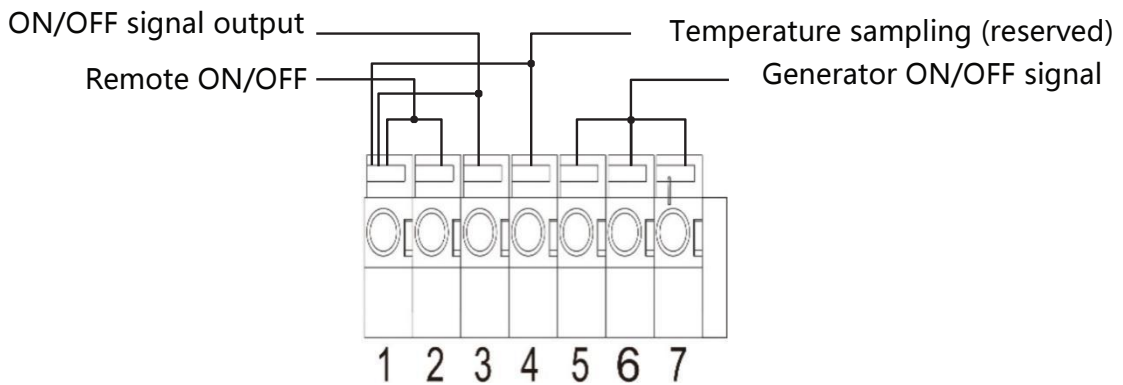

Function	Description
Remote ON/OFF	When pin 1 is connected to pin 2, the inverter will turn off the AC output. When disconnected, the inverter is in normal output.
ON/OFF signal output	When the battery voltage reaches the discharge limit voltage (parameter 15), the voltage between pin 3 and pin 1 is 0 V. When the battery is in normal charge or discharge status, the voltage between pin 3 and pin 1 is 5 V.
Temperature sampling (reserved)	Pins 1 and 4 can be used for battery temperature sampling compensation.
Remote generator start/stop	When the battery voltage reaches the under-voltage alarm voltage (parameter 14) or the voltage threshold for mains to switch to the battery (parameter 04), pins 6 to 5 are normally open, and pins 7 to 5 are normally closed. When the battery voltage reaches the voltage threshold for the battery to switch to mains (parameter 05), or the battery is fully charged, pins 6 to 5 are normally closed, and pins 7 to 5 are normally open. (5/6/7 pin output: 125 VAC/1 A, 230 VAC/1 A, and 30 VDC/1 A)

NOTICE

- If you need to use the remote start/stop function of the generator with dry contact, please ensure that the generator has an ATS and supports remote start/stop.

7. Fault Codes and Response Measures

7.1 Fault codes

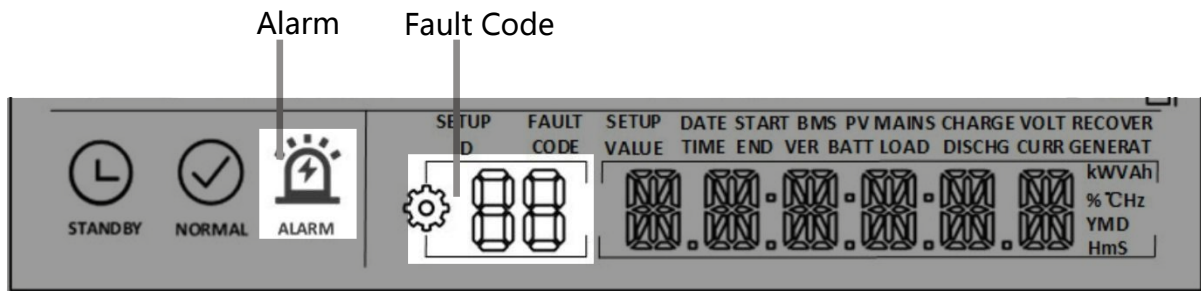

Fault Code	Meaning	Affect Output or Not	Description
01	BatVoltLow	Yes	Battery under-voltage alarm
02	BatOverCurrSw	Yes	Overcurrent software protection for average battery discharge current
03	BatOpen	Yes	Disconnected battery alarm
04	BatLowEod	Yes	Under-voltage battery discharge stop alarm
05	BatOverCurrHw	Yes	Battery overcurrent hardware protection
06	BatOverVolt	Yes	Charge overvoltage protection
07	BusOverVoltHw	Yes	Bus overvoltage hardware protection
08	BusOverVoltSw	Yes	Bus overvoltage software protection
09	PvVoltHigh	Yes	PV overvoltage protection
10	PvBoostOCSw	No	Boost overcurrent software protection
11	PvBoostOCHw	No	Boost overcurrent hardware protection
12	SpiCommErr	Yes	SPI communication fault of master and slave chips
13	OverloadBypass	Yes	Bypass overload protection
14	OverloadInverter	Yes	Inverter overload protection
15	AcOverCurrHw	Yes	Inverter overcurrent hardware protection
16	AuxDspReqOffPWM	Yes	Slave chip OFF request fault
17	InvShort	Yes	Inverter short-circuit protection
18	Bussoftfailed	Yes	Bus soft-start failure
19	OverTemperMppt	No	PV heat sink over-temperature protection
20	OverTemperInv	Yes	Inverter heat sink over-temperature protection

21	FanFail	Yes	Fan fault
22	EEPROM	Yes	Memory fault
23	ModelNumErr	Yes	Model setting error
24	Busdiff	Yes	Positive and negative bus voltage imbalance
25	BusShort	Yes	Bus short-circuit
26	Rlyshort	Yes	Inverter AC output backward to bypass AC output
28	LinePhaseErr	Yes	Mains input phase error
29	BusVoltLow	Yes	Bus low-voltage protection
30	BatCapacityLow1	Yes	Alarm of battery capacity rate below 10% (taking effect after BMS communication is successful)
31	BatCapacityLow2	No	Alarm of battery capacity rate below 5% (taking effect after BMS communication is successful)
32	BatCapacityLowStop	Yes	Battery low-capacity OFF (taking effect after BMS communication is successful)
34	CanCommFault	Yes	Parallel can communication fault
35	ParaAddrErr	Yes	Parallel ID (communication address) setting error
37	ParaShareCurrErr	Yes	Parallel current sharing fault
38	ParaBattVoltDiff	Yes	Large battery voltage difference in parallel mode
39	ParaAcSrcDiff	Yes	Inconsistent mains input source in parallel mode
40	ParaHwSynErr	Yes	Hardware synchronization signal error in parallel mode
41	InvDcVoltErr	Yes	Inverter DC voltage error
42	SysFwVersionDiff	Yes	Inconsistent system firmware version in parallel mode
43	ParaLineContErr	Yes	Parallel connection fault
44	Serialnumbererror	Yes	Failure to set the serial number before leaving factory
45	Errorsettingofsplit-phase mode	Yes	Setting error of setting items in parallel mode
56	Lowinsulation resistancefault	No	Abnormally low earth impedance of PV1+, PV2+, and PV-
57	Leakagecurrent overloadfault	Yes	System current leakage out of the standard
58	BMSComErr	No	BMS communication fault

60	BMSUnderTem	No	BMS under-temperature alarm (taking effect after BMS communication is successful)
61	BMSOverTem	No	BMS over-temperature alarm (taking effect after BMS communication is successful)
62	BMSOverCur	No	BMS overcurrent alarm (taking effect after BMS communication is successful)
63	BMSUnderVolt	No	BMS under-voltage alarm (taking effect after BMS communication is successful)
64	BMSOverVolt	No	BMS overvoltage alarm (taking effect after BMS communication is successful)

7.2 Troubleshooting

Fault Code	Meaning	Cause	Solution
/	No screen display	There is no power input, or the device switch at its bottom is not turned on	Check if the battery air-switch or PV air-switch has been closed; check if the switch is in "ON"; press any button on the screen to exit the screen sleep mode.
01	Battery under-voltage	The battery voltage is lower than the value set in parameter [14]	Charge the battery until the battery voltage exceeds the value set in parameter [14].
03	Disconnected battery	The battery is not connected, or the BMS of the lithium-ion battery is in the discharge protection state	Check if the battery is reliably connected; check if the circuit breaker of the battery is off; ensure that the BMS of the lithium-ion battery can communicate normally.
04	Battery over-discharge	The battery voltage is lower than the value set in parameter 12	Manual reset: Turn off the power, and restart Automatic reset: Charge the battery until the battery voltage is higher than the value set in parameter [35]
06	Rechargeable battery overvoltage protection	The battery is in the overvoltage state	Manually turn off the power, and restart Check if the battery voltage exceeds the limit. If the limit is exceeded, discharge the battery until the voltage is below the overvoltage recovery threshold of the battery
13	Bypass overload (software detection)	The output power or current of the bypass is overloaded within a	Reduce the load power, and restart the device. For more details, please refer to item 11 in Protection Function

		certain period	
14	Inverter overload (software detection)	The output power or current of the inverter is overloaded within a certain period	
19	Over-high temperature of the heat sink for PV input (software detection)	The temperature of the heat sink for PV input exceeds 90°C for 3s	Wait until the temperature of the heat sink is below the over-temperature recovery temperature, when charge and discharge return to normal
20	Over-high temperature of the heat sink for inverter output (software detection)	The temperature of the heat sink for inverter output exceeds 90°C for 3s	
21	Fan fault	Software detection finds the fan has a fault	Shut down, manually flick the fan, and check if any foreign objects are blocking it
26	AC input relay short-circuit	Stuck relay for AC output	Manually shut down, and restart. If the fault occurs again after restarting, contact the after-sales service personnel to repair the machine
28	Mains input phase fault	The phase of AC input is inconsistent with that of AC output	Ensure that the phase of AC input is the same as that of AC output. For example, if the output is in the split-phase mode, the input shall also be in the split-phase mode.

① NOTICE

If you encounter product faults that cannot be solved by the methods listed in the above table, please contact our after-sales service department for technical support, and do not disassemble the device by yourself.

8. Protection Function and Maintenance

8.1 Protection function

No.	Protection Function	Description
1	PV current-limiting protection	When the charge current or power of the configured PV array exceeds the rated current and power of the inverter, it will charge at the rated current and power
2	PV overvoltage protection	If the PV voltage exceeds the maximum allowable value of hardware, the machine will report the fault, and stop the step-up of PV to output sine AC waves
3	Reverse charge protection at night	At night, as the battery voltage is greater than that of the PV module, it will prevent the battery from discharging to the PV module
4	mains input overvoltage protection	When the mains voltage of each phase exceeds 140 VAC, it will stop mains from charging, and switch it to inverter output
5	Mains input under-voltage protection	When the mains voltage of each phase is lower than 90 VAC, it will stop mains from charge, and switch it to inverter output
6	Battery overvoltage protection	When the battery voltage reaches the overvoltage disconnect voltage threshold, it will automatically stop PV and mains from charging the battery, thus preventing damage to the battery due to overcharge
7	Battery under-voltage protection	When the battery voltage reaches the low-voltage disconnect voltage threshold, it will automatically stop discharging the battery, thus preventing damage to the battery due to overdischarge
8	Battery overcurrent protection	When the battery current exceeds the allowable range of hardware, the machine will turn off the output, and stop discharging the battery
9	AC output short-circuit protection	When a short-circuit fault occurs at the load output terminal, it will immediately turn off the output of AC voltage. Only after manually powering on the device, normal output restores
10	Heat sink over-temperature protection	When the internal temperature of the inverter is too high, the inverter will stop charging and discharging; when the temperature returns to normal, the inverter will charge and discharge again
11	Overload protection	After overload protection is triggered, the inverter output will be restored after 3 min, and after 5 times of overload, the output will be off until the frequency changer is restarted. (102% < load < 110%): An error will be reported, and the output will be turned off after 5 min. (110% < load < 125%): An error will be reported, and the output will be turned off after 10s. Load > 125%: An error will be reported, and the output will be turned off after 5s.

12	AC backward protection	Prevent the mains of battery inverter backward to bypass AC input
13	Bypass overcurrent protection	Built-in circuit breaker for AC input overcurrent protection
14	Bypass wiring error protection	When the phase of the two bypass inputs is different from that of the inverter split-phase, the machine will prohibit connecting to the bypass, thus preventing the power failure or short circuit of load when connecting to the bypass

8.2 Maintenance

In order to maintain the best long-term performance, it is recommended to conduct following checks twice a year.

1. Make sure that the airflow around the inverter is smooth, and remove any dirt or debris from the heat sink.
2. Check whether the insulation of all exposed wires is damaged by exposure to sunlight, friction with other objects around them, dryness, bite by insects or rodents, etc. Repair or replace wires if necessary.
3. Verify the consistency of the indication and display with the device operation. Please pay attention to any faults or errors, and take corrective actions if necessary.
4. Check all wiring terminals for corrosion, insulation damage, and signs of high temperature or burning/discoloration, and tighten the terminal screws.
5. Check for dirt, nesting insects, and corrosion, clean up as required, and clean the insectproof net regularly.
6. If the arrester fails, replace it in time against lightning damage to the inverter or even other devices of the user.

DANGER

- Before conducting any inspection or operation, please ensure that the inverter is disconnected from all power sources and that the capacitor is fully discharged to avoid the risk of electric shock.

Our company will not be held responsible for damage due to the following reasons:

1. Damage caused by improper use or use in the wrong location.
2. The open circuit voltage of the PV module exceeds the maximum allowable voltage.
3. The operating temperature exceeds the limited operating temperature range.
4. Unauthorized personnel dismantle, and repair the inverter.
5. Force majeure: damage during transportation or handling of the inverter

9. Parameter Table

Inverter Model	SPH8048P	SPH10048P	Settable
Inverter output			
Rated Output Power	8,000 W	10,000 W	
Max. Peak Power	16,000 W	20,000 W	
Rated Output Voltage	120/240 VAC (single-phase/split-phase)		Y
Loading Motor Capacity	5 HP	6 HP	
Rated Frequency	50/60 Hz		Y
Output Wave	Pure sine wave		
Switching Time	10 ms (typical value)		
Parallel Number	6		
Overload Protection	<p>After overload protection is enabled, the inverter output will be restored after 3 min, and after 5 times of overload, the output will be off until the inverter is restarted.</p> <p>(102% < load < 110%): An error will be reported, and the output will be turned off after 5 min.</p> <p>(110% < load < 125%): An error will be reported, and the output will be turned off after 10s.</p> <p>Load > 125%: An error will be reported, and the output will be turned off after 5s.</p>		
Battery			
Battery Type	Lithium-ion battery/lead-acid battery/user-defined battery		Y
Rated Battery Voltage	48 Vdc		
Voltage Range	40 Vdc–60 Vdc		Y
Max. PV Charge Current	180 A	200 A	Y

Max. Grid/Generator Charge Current	100 A	120 A	Y
Max. Hybrid Charging Current	180 A	200 A	Y
PV Input			
No. of MPPT Trackers	2		
Max. Input Power	11,000 W		
Max. Input Current	22/22 A		
Max. Open Circuit Voltage	500 Vdc		
MPPT Operating Voltage Range	125 Vdc–425 Vdc		
Mains/generator input			
Input Voltage Range	90 VAC–140 VAC		
Input Frequency Range	50/60 Hz		
Bypass Overload Current	63 A		
Efficiency			
MPPT Tracking Efficiency	99.9%		
Max. Efficiency of Battery	92%		
General			
Dimension	620 mm*445 mm*130 mm		
Weight	27 kg		
Protection level	IP20, for indoor use only		
Ambient temperature	–10°C–55°C, >45°C derating		
Noise	<60 dB		
Cooling mode	Intelligent fan		
Communication			
Built-in interface	RS485/CAN/USB/dry contact		Y
External module (optional)	Wi-Fi/GPRS		Y
Certification			
Safety	IEC62109-1, IEC62109-2, and UL1741		
EMC	EN61000-6-1, EN61000-6-3, and FCC 15 class B		
RoHS	Yes		

PowerMax 314 Outdoor Series

Energy Storage Battery User Manual

V3.0



1. Instructions

Thank you very much for choosing the PowerMax 314 Outdoor series household energy storage system developed and produced by our company. Please read and understand all contents of the Manual carefully

before installing and using the product. If you have any suggestions during the use, please do not hesitate to give us feedback.

The product must be used in compliance with all local standards, laws, and regulations. Any non-compliant use may lead to personal injury and property loss.

The drawings provided in this Manual are used to explain the concepts related to the product, including product information, installation guide, electrical connection, system debugging, safety information, common problems and maintenance, etc.

The internal parameters of this product have been adjusted before delivery. No internal parameters can be changed without permission. Any unauthorized changes to the settings will invalidate the warranty, and the Company will not be liable for any loss resulting therefrom.

This Manual and other related documents are an integral part of the product and should be kept properly for onsite installation personnel and related technical personnel to consult.

In order to continuously improve customer satisfaction, both this product and the Manual are continuously being improved and upgraded. If there is a discrepancy between the received manual and the product, it may be due to a product version upgrade. Please refer to the actual product.

The Manual will be continuously updated and revised, but it is inevitable that there may be slight discrepancies or errors with the actual product. Please refer to the actual product purchased by the user. The pictures mentioned in this document are for reference only and the actual product shall prevail.





1.1 Meaning of Abbreviations

AC	Alternating Current
DC	Direct Current
PV	Photovoltaic
BMS	Battery Management System
PCS	Power Conversion System
RJ45	Registered Jack 45
SOC	State Of Charge
C	Charge C-rate
RS485	RS485 Communication Interface
CAN	Controller Area Network

1.2 Symbol Stipulations

There may be following symbols herein, and their meanings are as follows.











Symbols	Description
---------	-------------



	<i>Indicate a hazard with a high level of risk which, if not avoided, will result in death or serious injury.</i>
	<i>Indicate a hazard with a medium level of risk which, if not avoided, could result in death or serious injury.</i>
	<i>Indicate a hazard with a low level of risk which, if not avoided, could result in minor or moderate injury.</i>
	<i>Warning information about device or environment safety. If not avoided, equipment damage, data loss, performance degradation or other unanticipated results may be resulted in. The "NOTICE" does not involve any personal injury.</i>

2 Safety Precautions

2.1 Safety Symbols

This product contains the following symbols, please pay attention to identifying.

Symbols	Description
	<i>Observe enclosed documentation</i>
	<i>Danger. Risk of electric shock!</i>
	<i>Danger of high voltages. Danger to life due to high voltages in the Energy storage system</i>
	<i>Hot surface</i>
	<i>CE certification</i>
	<i>Do not touch the product in 5mins after shutdown</i>
	<i>Comply with RoHS standard</i>
	<i>The Energy storage system should not be disposed together with the household waste.</i>
	<i>Flammability risk</i>
	<i>Electric shock hazard</i>
	<i>Keep the battery away from open flame or ignition sources</i>

	<p>Keep the battery away from electric sparks</p>
	<p>Recycling</p>
	<p>Rainproof and moisture-proof</p>

2.2 General Safety



2.2.1 Important Notice







Before installing, operating, and maintaining the device, please read this Manual first and follow the symbols on the device and all the safety precautions in this Manual.

The "DANGER", "CAUTION", "ATTENTION", and "NOTICE" indicators in this manual are not exhaustive of all safety considerations but serve as supplements to all safety precautions. The Company will not be liable for any violation of general safety operating requirements, or any violation of safety standards for the design, production, and use of the device. The device must be used in an environment that meets the requirements of the design specifications. Otherwise, the device may fail, and the abnormal device function or component damage, personal safety accident, and property loss arising from this are not covered within the quality assurance scope of the device. When installing, operating, and maintaining the device, the local laws, regulations, and codes shall be followed. The safety precautions in this Manual are only supplements to local laws, regulations, and codes. The Company shall not be liable for any of the following circumstances.

- The device is not run under the conditions of operating described in this Manual.
- The installation and operating environment is beyond the requirements of relevant international or national standards.
- The product is disassembled or changed, or the software code is modified without authorization.
- The operation instructions and safety warnings related with the product and in the documents are not followed.
- Damage of the device is caused by abnormal natural environment (force majeure, such as earthquake, fire, and storm).
- Transportation damage is caused during customer's own transportation.
- The storage condition does not meet the requirements of the product related documents and causes damage.

2.2.2 General Requirements

	<p>Operating while powered on during installation is strictly prohibited.</p>
	<p>It is strictly prohibited to install, use, and operate any outdoor equipment or cables (including but</p>

	<i>not limited to transporting equipment, operating equipment and cables, plugging and removing signal ports connected to the outdoor, working at altitude, and outdoor installation) in severe weather, such as thunder, rain, snow, and gale level 6.</i>
	<i>In case of any fire, evacuate the building or equipment area and press the fire alarm bell or dial the fire call. Under any circumstances, re-entry into a burning building is strictly prohibited.</i>
	<i>Under no circumstances should the structure and installation sequence of the device be changed without the manufacturer's permission.</i>
	<i>The battery terminal components shall not be affected during transportation. And, the battery terminal bolts shall not be lifted or transported.</i>
	<i>It is strictly prohibited to alter, damage or block the marks and nameplates on the device.</i>
	<i>The composition and working principle of the entire photovoltaic power generation system, as well as the relevant standards of the country/region where the project is located shall be known fully.</i>
	<i>After the device is installed, the empty packing materials, such as cartons, foam, plastics, and cable ties, shall be removed from the device area.</i>

2.2.3 Personnel Safety

- *When operating the device, appropriate personal protective equipment shall be worn. If any fault that may lead to personal injury or damage of the device is found, immediately terminate the operation, report to the responsible person, and take effective protective measures.*
- *Before using any tools, learn the correct method of using the tool to avoid injuries and damage of the device.*
- *When the device is running, the temperature of the case is high, which may cause burns. Therefore, do not touch the case.*
- *In order to ensure personal safety and normal use, reliable grounding should be carried out before use.*
- *Do not open or damage the battery. The electrolyte released is harmful to skin and eyes, so avoid touching it.*
- *Do not place irrelevant items on the top of the device or insert them into any part of the device.*
- *Do not place flammable items around the device.*
- *Never place the battery in the fire to avoid explosion and prevent the personal safety from being endangered.*
- *Do not place the battery module in water or other liquids.*
- *Do not short-circuit the battery terminals, because short-circuiting of the battery may cause combustion.*
- *The battery may pose electric shocks and large short-circuit currents. When using the battery, the following precautions should be paid attention to:*
 - a) *The metal objects, such as watch and rings, shall be removed.*

- b) *Tools with insulated handles should be used.*
 - c) *Rubber gloves and shoes should be worn.*
 - d) *The charging power supply shall be disconnected before connecting or disconnecting terminals of the battery.*
 - e) *Check whether the battery is accidentally grounded. If the battery is accidentally grounded, remove the power supply from the ground.*
- *Do not clean the internal and external electrical components of the cabinet with water or detergent.*
 - *Do not stand, lean or sit on the device.*
 - *Do not damage any modules of the device.*

2.3 Personnel Requirements

- *The personnel in charge of installation and maintenance must be strictly trained to understand all safety precautions and master proper operation methods.*
- *Only qualified professionals or trained personnel are allowed to install, operate and maintain the device.*
- *The personnel who operate the device, including the operators, trained personnel and professionals, must have special operation qualifications required by the local country, such as high voltage operation, working high above the ground, and special equipment operation qualification.*
- *The replacement of device or components (including software) must be carried out by professionals or authorized personnel.*

2.4 Electrical Safety

2.4.1 General Requirements



Before making electrical connections, ensure that the device is not damaged; otherwise, electric shock or fire may occur.



Never install or remove any power cables when the power is on. The electric arcs or sparks may be generated at the moment when the power cable contacts with the conductor, which may cause fire or personal injuries.

- *All the electrical connections must meet the electrical standards of the country/region where the project is located.*
- *The cables prepared by users themselves shall comply with local laws and regulations.*
- *Special insulating tools should be used in high-voltage operations.*
- *Before connecting the power cord, ensure that the label identification on the power cord is correct.*
- *Operations on the device are allowed only five minutes after the device is completely powered off.*
- *The insulation layer of the cable may be aged or damaged when the cable is used in a high temperature environment. Therefore, the distance between the cable and the heat source must be at least 30mm.*

- Cables of the same type should be bundled together. Whereas the cables of different types should be routed at least 30mm apart, and shall not be wrapped together or crossed.

2.4.2 Grounding Requirements

- When installing the device to be grounded, the protective grounding wire must be installed first; when removing the device, the protective grounding wire must be removed at last.
- It is forbidden to destroy the grounding conductor.
- It is forbidden to operate the device without a grounding conductor installed.
- The device shall be permanently connected to the protective grounding wire. Before operating the device, electrical connection of the device shall be checked to ensure that the device is reliably grounded.

2.5 Installation Environment Requirements

- Do not install or use this product in an environment where the temperature is lower than -10 °C or higher than 50 °C.
- It should be installed in a dry and well-ventilated environment to ensure good heat dissipation performance.
- The product can be installed at a maximum altitude of 2,000m(6561ft).
- The installation position should be away from the fire source.
- The product should be installed and used away from children and animals.
- The installation position should be far away from water sources, such as faucets, sewer pipes, and sprinklers, to avoid entering of water.
- The device should be placed on a firm and flat supporting surface.
- Do not place any inflammable or explosive items around the device.
- When the device is running, do not block the ventilation vent or heat dissipation system to prevent fire caused by high temperature.



The operation and service life of the energy storage is related to the operating temperature. The energy storage should be installed at a temperature equal to or better than the ambient temperature.



Max+50°C



Min-10°C



RH.+5%~+95%

3 Product Introduction

3.1 Battery Specifications

Product model	PowerMax 314 Outdoor
Rated voltage	51.2V
Voltage Range	44.8~57.6Vdc

Rated capacity	314Ah
Rated energy	16.07kWh
Nameplate Energy Capacity	16.07kWh
Usable Energy	15.42kWh
Max.Depth of discharge	> 96%
Rated DC power	7.68kW
Maximum continuous Discharge Rate	7.68kW
Weight	123kg (271lb)
Dimensions (L*W*H)	1048*460*271mm (41.26*18.11*10.67inch)
Standard charge / discharge current	150A/150A
Max. Charging / discharging current	190A/190A
Peak charging current	220A (3S)
Peak discharging current	220A (3S)
Breaker Current	240A
Screen	Touch Screen
Battery type	LFP
Life cycle (80% DOD,0.5C,25℃)	8000 Cycles
Max. charging voltage	57.6V
Over discharge voltage	44.8V
Max. number of parallel	16
Communication interfaces	CAN/RS485/USB/WIFI/Bluetooth
Lithium Battery Standard	UN38.3, MSDS, EN55032, EN55024, EN61000-3-2, EN61000-3-3, UL1973,UL9540A
Storage time / temperature	6 months @25℃ (77°F) ;3 months @35℃ (95°F) ;1 months @45℃ (113°F) ;
Charging temperature range	0~55℃ (32~131°F)
Discharging temperature range	-10~55℃ (14~131°F)
Cooling method	Natural cooling
Enclosure protection rating	IP65
Operation Environment	Indoor & Outdoor

3.2 Appearance Description

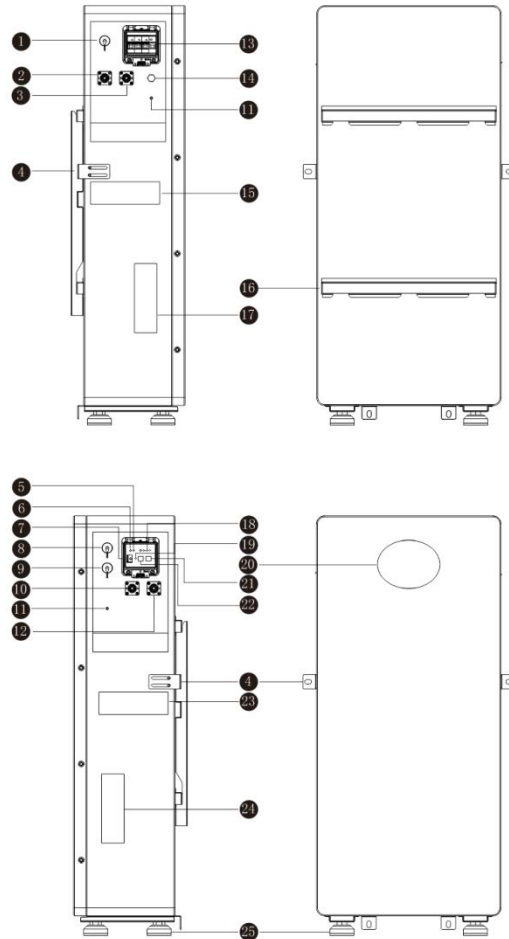

1, RS485 (Connect other battery)	2, Battery Negative	3, Battery Positive	4, Fixed accessories
5, LED(ALM)	6, LED(RUM)	7, Turn On/Off	8, RS485/CAN (Connect inverter)
9, RS485 (Connect other battery)	10, Battery Positive	11, Grounding screw	12, Battery Negative
13, Breaker	14, vent valve	15, Handle (15) plus (23) are used simultaneously	16, Mounting Frame
17, Handle (17) plus (24) are used simultaneously	18, SOC (State of Capacity)	19, Reset	20, LCD Touch Screen
21, USB (Connect PC)	22, Address	23, Handle(15) plus (23) are used simultaneously	24, (17) plus (24) are used simultaneously
25, Foot cup			

Communication interface definition

Number	Communication	Interface Type	Picture	instruction
--------	---------------	----------------	---------	-------------

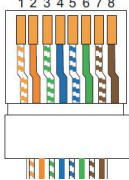
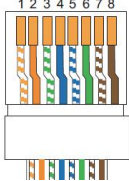
<p>①⑬</p>	<p>RS485 (Connect other battery)</p>	<p>RJ45</p>		<p>1-RS485-B 2-RS485-A 7-RS485-A 8-RS485-B</p>
<p>⑩</p>	<p>RS485/CAN (Connect inverter)</p>	<p>RJ45</p>		<p>1-RS485-B 2-RS485-A 3-GND 4-CAN-H 5-CAN-L 6-GND 7-RS485-A 8-RS485-B</p>

4 Application Scenarios

The lithium iron phosphate batteries with high performance and long service life are used in the energy storage module. Meanwhile, the modular structure design is adopted. Each energy storage module is internally integrated with the intelligent BMS system, which can be easily expanded and can be combined into 60Kwh battery pack at most.

The battery storage can be combined with inverter to form an off-grid photovoltaic system, which can solve the problem of electricity consumption in areas without electricity.

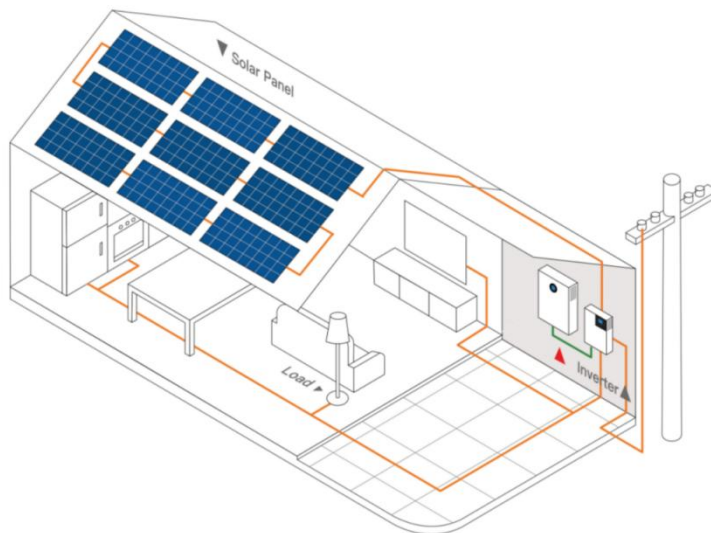

5 System Installation











5.1 Inspections before Installation

Inspection of outer package

Before opening outer package of the energy storage, check if there is any visible damage on the outer package, such as holes, cracks or other signs of possible internal damage, and check the type of energy storage. If there is any abnormality on the package or model of the energy storage is inconsistent, do not open it and contact us as soon as possible.



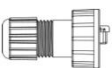



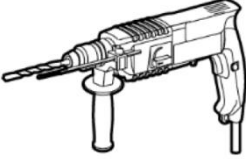

Inspection of deliverables

After opening outer package of the energy storage, check if the deliverable is complete and whether there is any visible external damage. If any items are missing or damaged, please contact us.

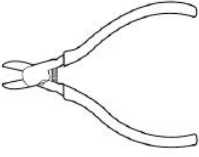
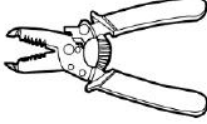
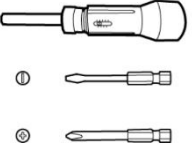
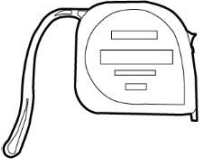
NO.	Picture	Item	Quantity	Specification
1		Battery Pack	1	16.07kWh
2		Mounting Frame	3	580*85.8*30mm
3		Mounting Frame Connecting Strip	1	375*39*12mm
4		Screw	6	M4*10
5		Mounting Frame Screw	12	M8*60 expansion bolt
6		Side fastener	2	80*40*36mm
7		Screw	4	M5*12
8		Power Cable	2	1.5m
9		Signal cable	1	RJ45, 1.5m
10		RJ45 waterproof connector	1	M25*37mm
11		Installation auxiliary board	1	500*500mm
12		Grounding Wrie	1	1.5m

5.2 Preparation of Tools and Meters

Types	Tools and meters
-------	------------------

<i>Installation tool</i>			
			
			
<i>Personal protective equipment</i>			
			

5.3 Selection of Installation Location

5.3.1 Basic Requirements

- *When the energy storage is running, the temperature of the case and the radiator will be high. Therefore, do not install them in a place that is easy to touch.*

- *Do not install in areas where flammable and explosive materials are stored.*

- *If the energy storage is installed in areas with salt damage, it will be corroded and may cause fire.*

Therefore, do not install it outdoors in areas with salt damage. The areas with salt damage are defined as the areas which are not 500m away from shore or will be affected by sea breezes. The areas affected by the sea breezes vary depending on meteorological conditions (e.g. typhoons, monsoons) or topographical conditions (dams, hills).

- *Do not install in the place where children can touch.*

- *The energy storage cannot be installed forwardly, horizontally, inversely, backwardly or sideways.*

- *When drilling holes on walls or ground, the goggles and protective gloves shall be worn.*

- *During drilling, the device should be shielded to prevent debris from falling into the device. After drilling, the debris shall be cleaned up in time.*

- *When handling any heavy objects, you should be prepared to bear loads to avoid being crushed or sprained.*

- *When handling the device by hand, wear protective gloves to avoid injury.*

5.3.2 Installation Space Requirements

Floor Mount: The battery should be placed in the right position first, and the installation site should be smooth, and the wall should be solid, and the distance between the batteries should be greater than 200-350mm.

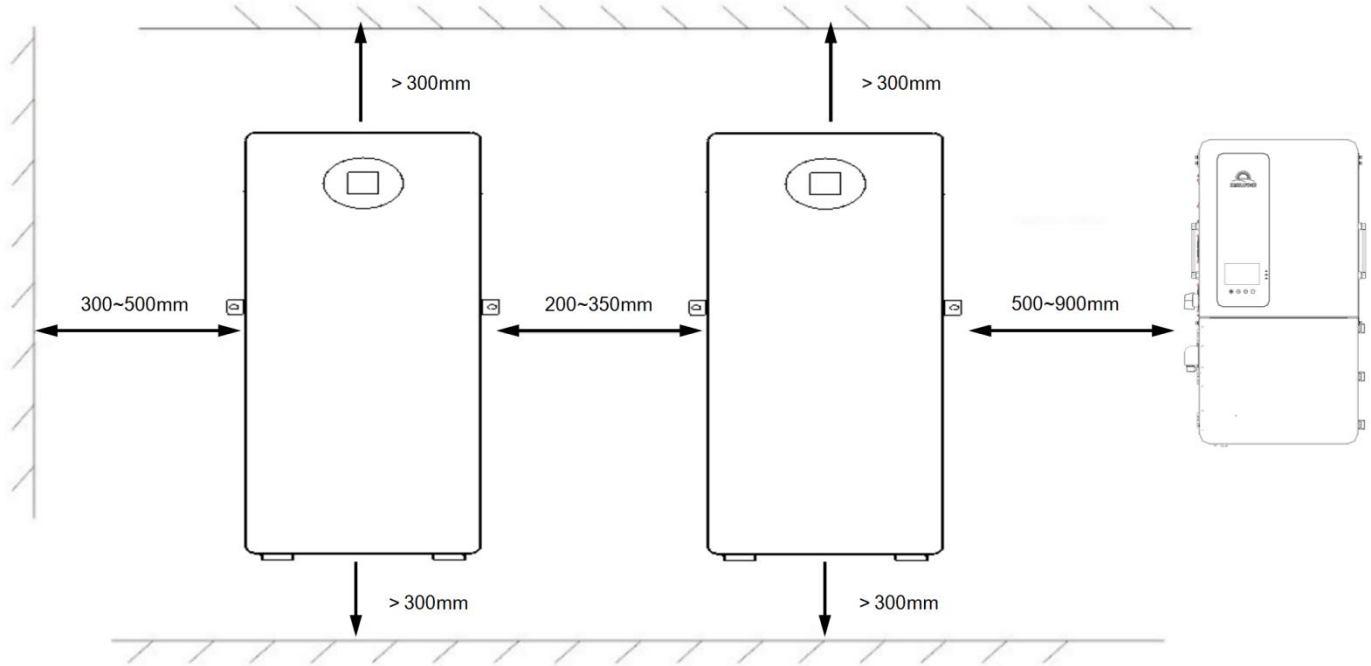

Wall mount: The battery should be placed in the right position first, and the installation site should be smooth, and the wall should be solid, and the device is 200mm away from the ground, the distance between the batteries should be greater than 200-350mm.

5.4 Device Installation

5.4.1 Wall mount

5.4.1.1 Installation Location Selection

Determine the installation position, put the installation auxiliary board in the proper position, and mark the place where the holes need to be punched.

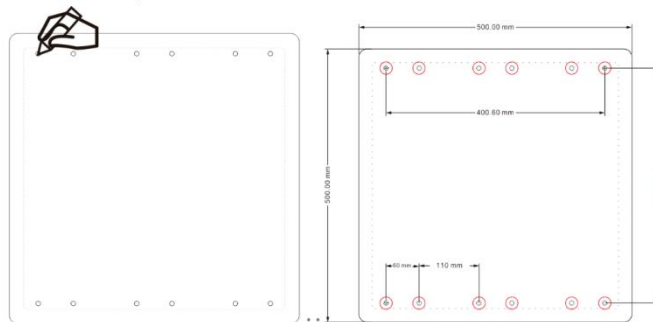

5.4.1.2 Install Expansion Bolts



To avoid electrical shock or other injury, inspect existing electronic or plumbing installations before drilling holes.



Choose suitable firm wall with thickness greater than 80mm.

Drill 12 holes according to the hole position, it is $\phi 10$ with depth of 45~50mm. Hammer the M8 screws to the above holes, and screw the nut.

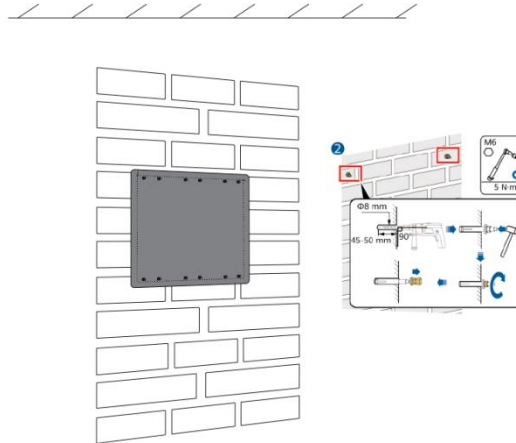

5.4.1.3 Install Bracket Screws

Secure the mounting bracket with 6 screws.

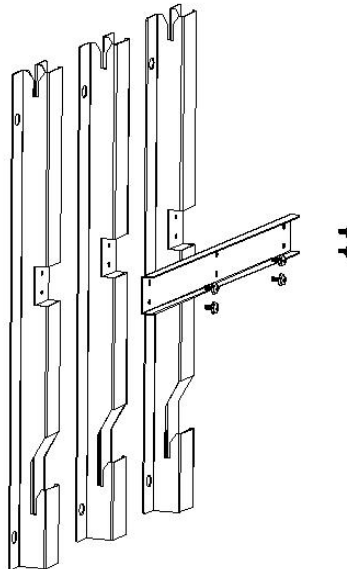

5.4.1.4 Fix Mounting Frame

Make the convex side outward and fix the mounting frame to the 12 screws.

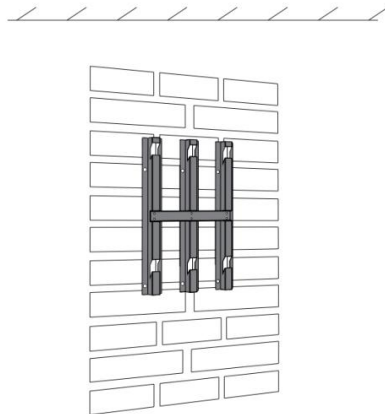

5.4.1.5 Install Battery Pack



The battery pack is very heavy, which requires multiple people to install.

Keep the battery balanced, and then slowly hang the battery on the frame through the match hooks.

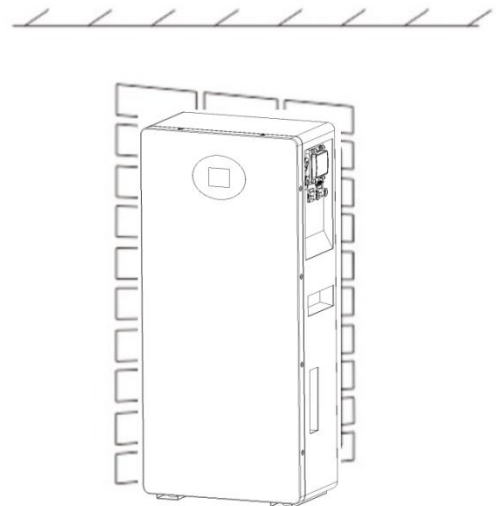
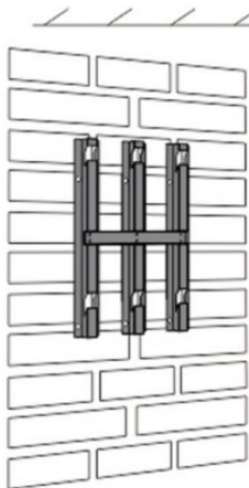

5.4.2 Floor Mount

5.4.2.1 Install Expansion Bolts



To avoid electrical shock or other injury, inspect existing electronic or plumbing installations before drilling holes.

Drill 2 holes according to the hole position, it is $\phi 10$ with depth of 45~50mm. Hammer the M8 screws to the above holes, and screw the nut.

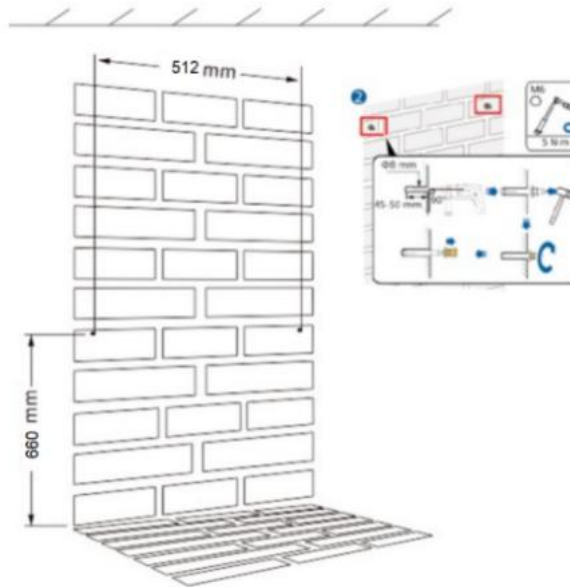

5.4.2.2 Install Battery Pack

Place the battery on a flat, firm floor and install the fixing accessories.

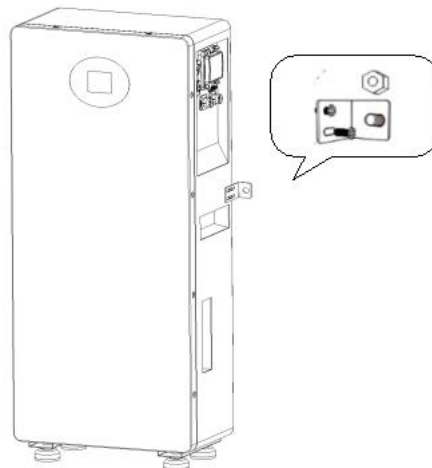

6 Electrical Connection





Before electrical connection, please ensure that the switches of the energy storage are in the "OFF" state. Otherwise, the high voltage of the device may cause electric shock.



The operations related to electrical connections must be carried out by professional electrical technicians. When carrying out electrical connections, the operator must wear personal protective articles.

6.1 Preparation of Cables

No.	Cables	Description	Recommended specifications	Source
1	Power Cable	Power cable between the storage battery and inverter		Provide with the product together
2	Signal line	Signal cable between battery modules or between battery and inverter		Provide with the product together
3	Ground wire	Ground cable between the storage battery modules		Provide with the product together
4	Photovoltaic input line	Cable between the photovoltaic panel and power module	Cable diameter 6mm ² /10AWG	Prepare by the user

6.2 Electrical Connection of One Battery Module

6.2.1 Connecting Grounding Wire

Each energy storage battery module shall relate to the grounding wire provided with the product together.

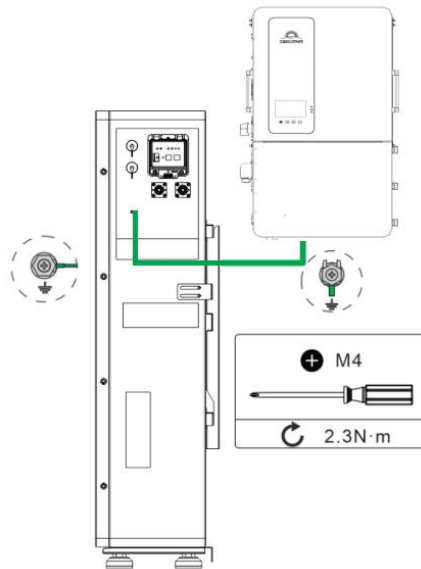

6.2.2 Connecting Power Cord

When connecting the battery wiring, please make sure that the battery switch is off and the indicator light is off. If the plug is connected properly, you will hear a "click" sound.

If you need to unplug the plug, you need to first turn off all devices and battery switches, and then wait for 5 minutes before proceeding, then press the self-locking clasp and unplug.

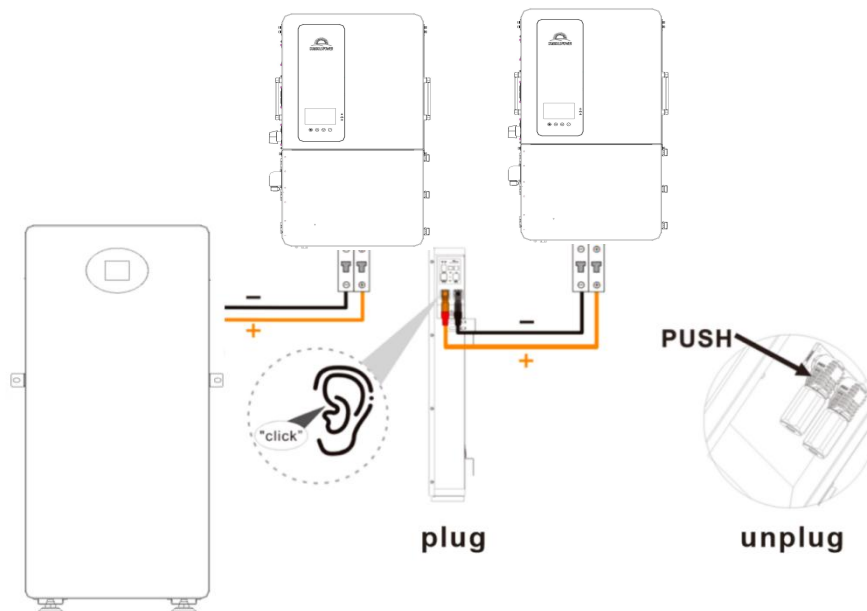

6.2.3 Connecting Signal Line

The signal line shall be used to connect RS485-Inverter interface for battery module and inverter.

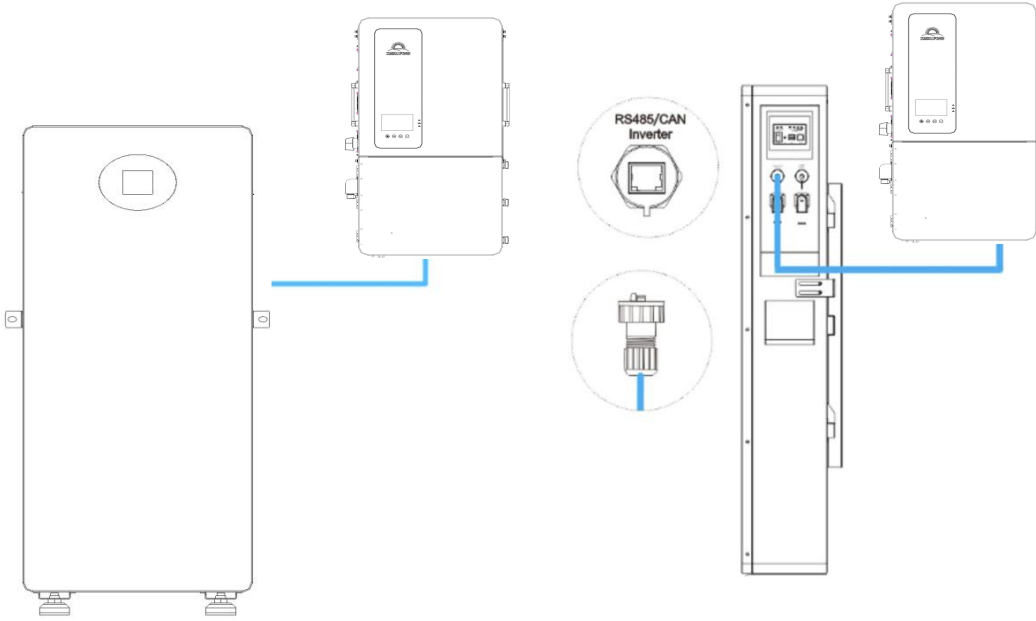

When connecting the inverter, the communication line must be connected, and the communication protocol must be consistent.



If you use a standard network cable, please cut off pins 1 and 2 for connection.

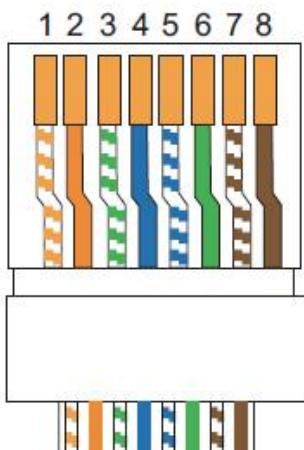

If you use a standard network cable to connect the inverter

PIN1	White-orange	RS485-B
PIN2	Orange	RS485-A
PIN3	White-green	
PIN4	Blue	CAN-H
PIN5	White-blue	CAN-L
PIN6	Green	
PIN7	White-brown	RS485-A
PIN8	Brown	RS485-B

6.2.4 Energy Storage Battery Module Address Setting

When using a single battery, please set the address to 0.

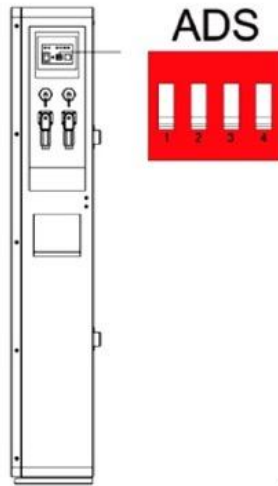

6.3 Electrical Connection of Multiple Battery Modules

6.3.1 Connecting Grounding Wire

Each energy storage battery module shall be connected with the grounding wire provided with the product together. If there are multiple batteries, you need to connect the ground wire of each battery.

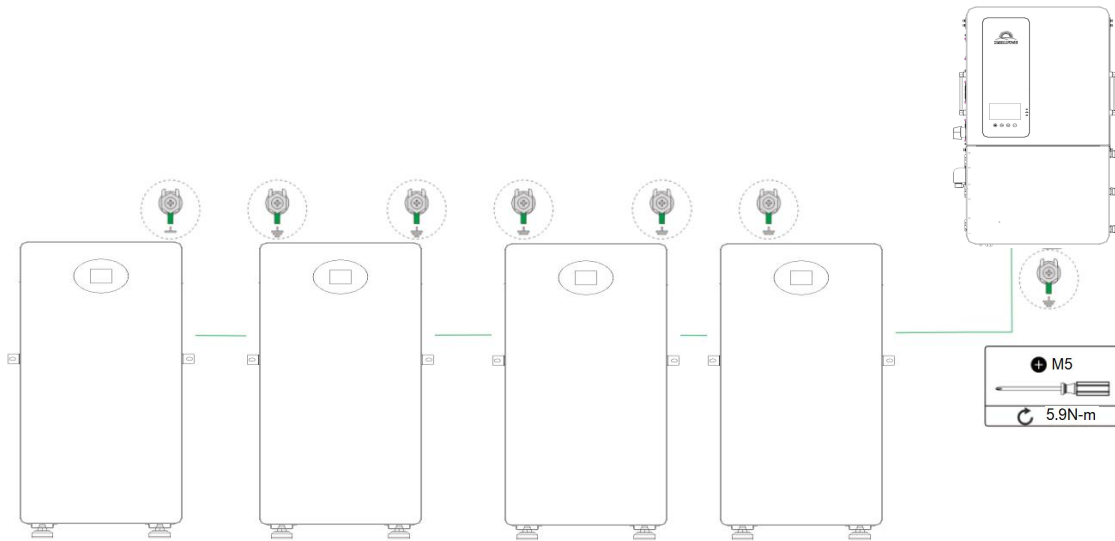

6.3.2 Connecting Power Cord

If there are 2 batteries used in parallel, you need to connect the power cord of each battery.

Parallel connection cable of battery modules are optional products. If necessary, please contact your local dealer.



If the current of the inverter exceeds the rated current of the battery, a busbar must be used and parallel connection cable cannot be used. Parallel connection cable can only expand capacity, not power.



Batteries can only be connected in parallel and cannot be used in series

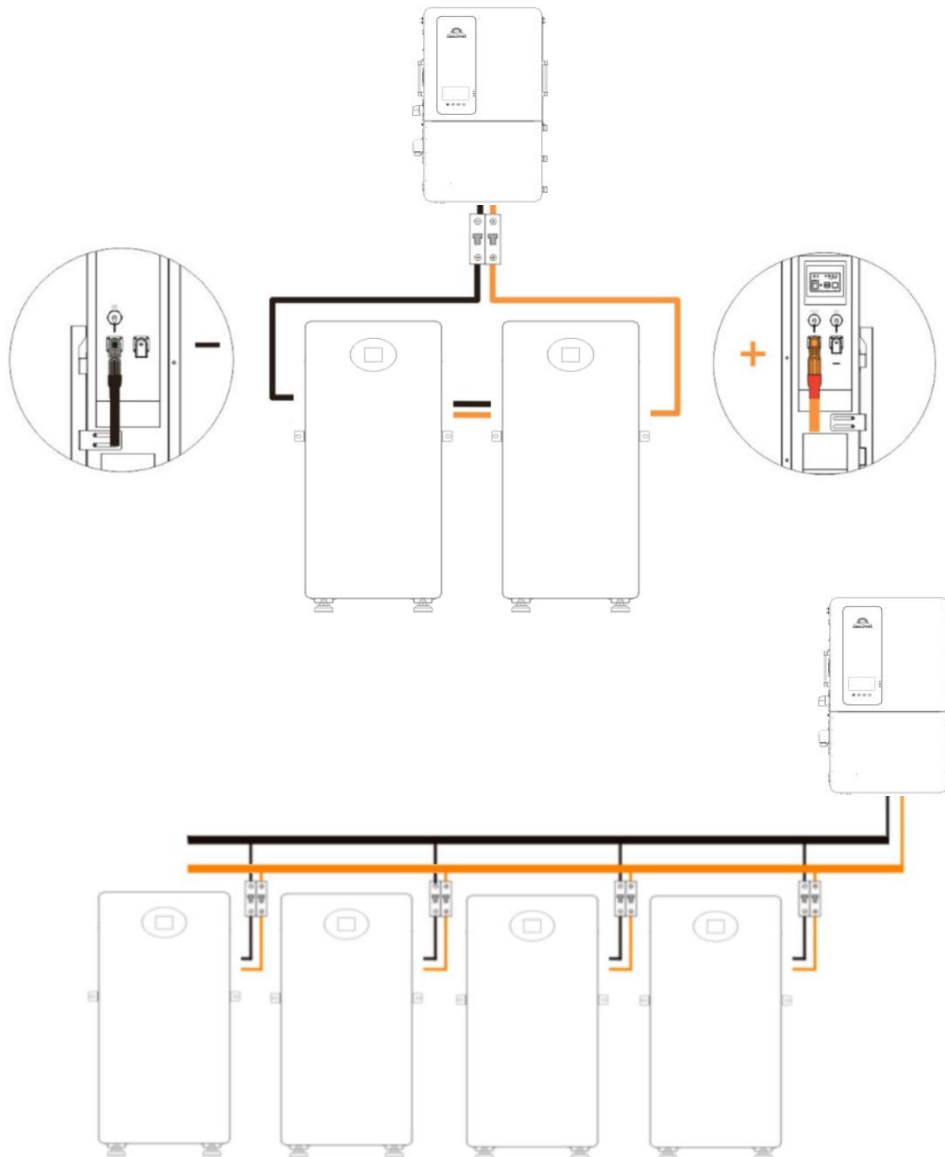

If multiple batteries are used in parallel, Bus bar is required.

6.3.3 Connecting Signal Line



If there are multiple batteries connected in parallel, the slave switch must be turned on first, and then the master switch should be turned on last.

If there are multiple batteries, you need to connect the communication line of each battery. Battery and battery connection use RS485-Battery interface, battery and inverter connection need RS485-Inverter interface.

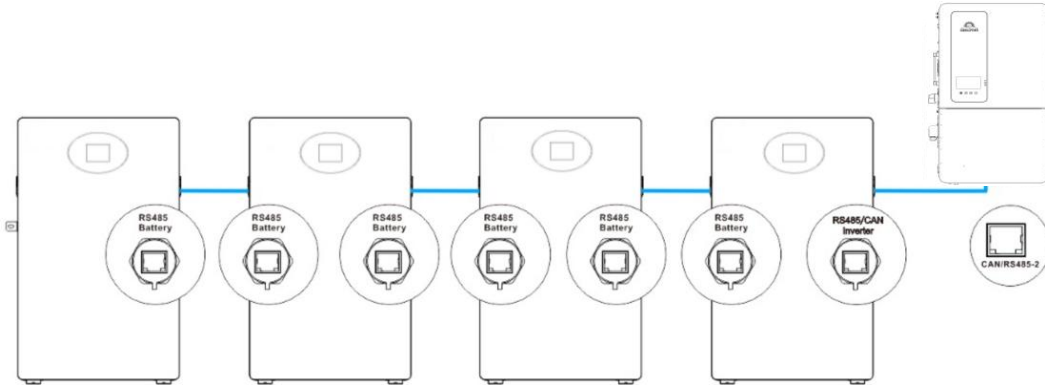

Multiple battery connections require assembly of the RJ45's waterproof connector, exploded view of RJ45 waterproof connector:



6.3.4 Energy Storage Battery Module Address Setting



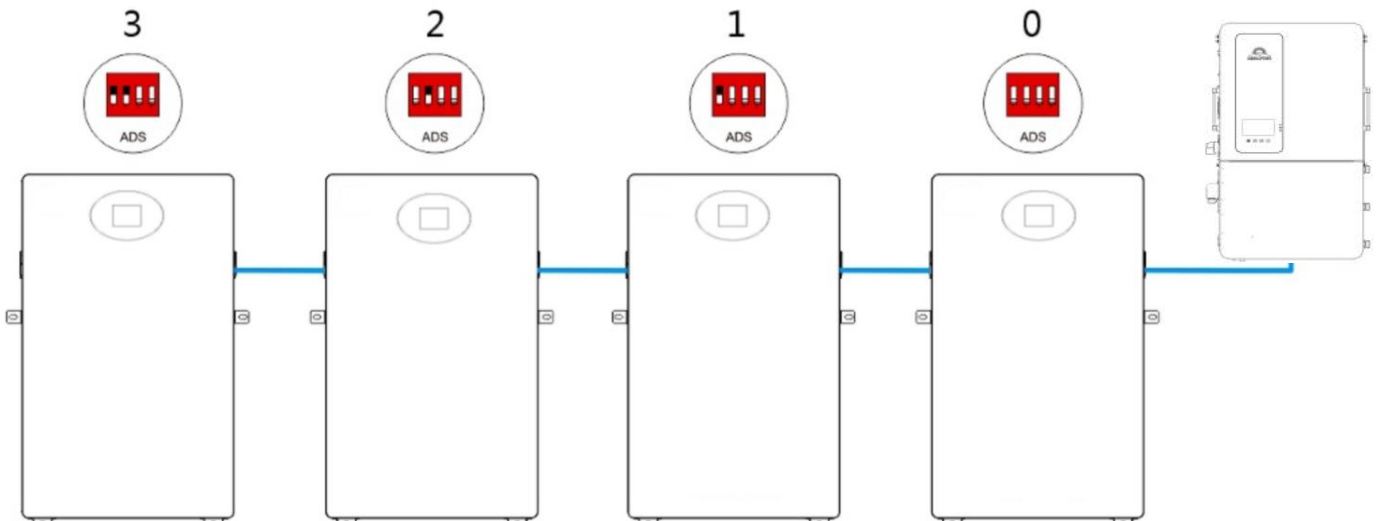















If multiple energy storage battery modules are used in parallel, the address of the energy storage battery module needs to be set. The address should be set as 0~8, and the address of each module cannot be repeated.



The address of the battery connected to the inverter must be set as 0.

Multiple batteries parallel DIP switch location description, up to 16 batteries can be used in parallel.

Addr.	DIP Switch Position	Master or Slave Battery	Connect the inverter
-------	---------------------	-------------------------	----------------------

0		Master	√
1		Slave1	×
2		Slave2	×
3		Slave3	×
4		Slave4	×
5		Slave5	×
6		Slave6	×
7		Slave7	×
8		Slave8	×
9		Slave9	×
10		Slave10	×
11		Slave11	×
12		Slave12	×
13		Slave13	×
14		Slave14	×
15		Slave15	×
 : off  : on			

7 System Debugging

7.1 Inspections Before Power-On

No	Inspection items	Acceptance criteria	Validation
1	The energy storage is installed in place	The installation is correct, secure and reliable.	<input type="checkbox"/> Yes <input type="checkbox"/> No
2	The installation environment meets requirements	The installation space is reasonable, and the environment is clean and tidy without any construction	<input type="checkbox"/> Yes <input type="checkbox"/> No
3	The power cord is correctly connected	The positive and negative terminals are connected correctly without any missing.	<input type="checkbox"/> Yes <input type="checkbox"/> No
4	The signal line is correctly connected	The signal line is connected reliably, and there is no wrong position	<input type="checkbox"/> Yes <input type="checkbox"/> No
5	The grounding is reliable	The grounding wire is correctly and reliably connected.	<input type="checkbox"/> Yes <input type="checkbox"/> No
6	The switch of the energy storage battery module is off	All switches connected to the energy storage are in the "OFF" state.	<input type="checkbox"/> Yes <input type="checkbox"/> No

7.2 Power-On of Battery Module

7.2.1 Power-up Sequence

After the battery is connected to the inverter, please power on in the following order.

First, turn on the breaker switch, if there are multiple battery modules, turn on all the breaker switches.

Secondly, turn on the battery switch button and the battery start to work. If there are multiple modules, please turn on the power switch one by one according to the address sequence.

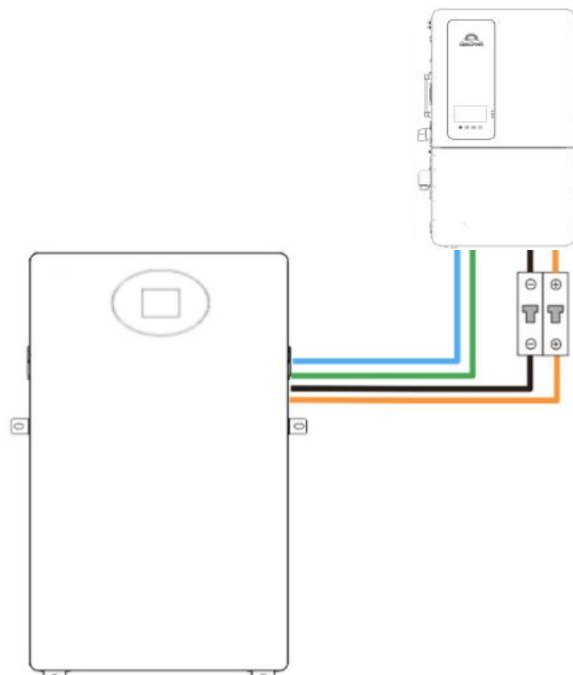

7.2.2 System Status Indication

After the battery switch button is turned on, the LED indicator will light up or flash. The meaning of the LED indicator is as follows.

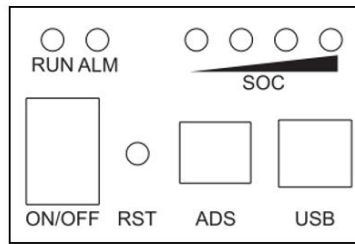

System Status	Events	RUN	ALM
POWER OFF	Power Off	OFF	OFF
Steady	Normal	Blinking1	OFF
	Alarm	Blinking1	Blinking3
Charging	Normal	ON	OFF
	Alarm	ON	Blinking3
	Over Charge Protection	ON	OFF
	High temperature, Over Current	OFF	ON
Discharging	Normal	Blinking3	OFF
	Alarm	Blinking3	Blinking3
	Over Discharge Protection	OFF	OFF
	Over Current, Short Current	OFF	ON

LED blinking description

Blinking	LED ON	LED OFF
Blinking1	0.25S	3.75S
Blinking2	0.5S	0.5S
Blinking3	0.5S	1.5S

7.2.3 Capacity indicator

Capacity indicator LED	SOC
	0~25%
	25~50%
	50~75%
	75~100%

7.2.4 LCD Touch Screen

7.2.4.1 Main Page

ID	Value
----	-------

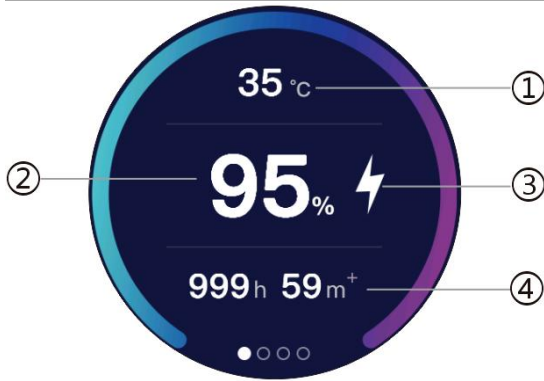

①	Battery temperature
②	SOC
③	Charging indication
④	Discharge remain time







7.2.4.2 Warning Page



ID	Value
①	Battery voltage
②	Warning and Protection
③	Battery current

Warning and protection information is as follows.

1		Normal	
		Over voltage Warning	The battery voltage exceeds the warning value, but the BMS will not stop charging, and the inverter needs to actively stop charging.
		Over voltage Protection	The battery voltage exceeds the protection value, the BMS will actively stop charging.
2		Normal	
		Over discharge Voltage Warning	The battery voltage is lower than the warning value, but the BMS will not stop discharging, and the inverter needs to actively stop discharging.
		Over discharge Voltage Protection	The battery voltage is lower than the protection value, the BMS will actively stop discharging.
3		Normal	

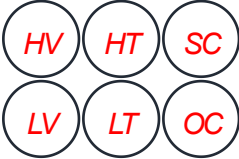
		Over Temperature Warning	The battery temperature is higher than the warning value, but the BMS will not stop charging and discharging, and the inverter needs to actively stop charging and discharging.
		Over Temperature Protection	The battery temperature is higher than the protection value, the BMS will actively stop charging and discharging.
4		Normal	
		Low Temperature Warning	The battery temperature is lower than the warning value, but the BMS will not stop charging and discharging, and the inverter needs to actively stop charging and discharging.
		Low Temperature Protection	The battery temperature is lower than the protection value, the BMS will actively stop charging and discharging.
5		Normal	
		Short Circuit Protection	The battery output is short-circuit protected, and the BMS stops discharging.
6		Normal	
		Overcurrent Protection	The charging current or discharging current is too large, the BMS stops charging or discharging
7			Hardware failure, please stop using immediately, and contact a professional maintenance personnel to deal with.

7.2.4.3 Cell Voltage Page

ID	Value
①	Battery voltage

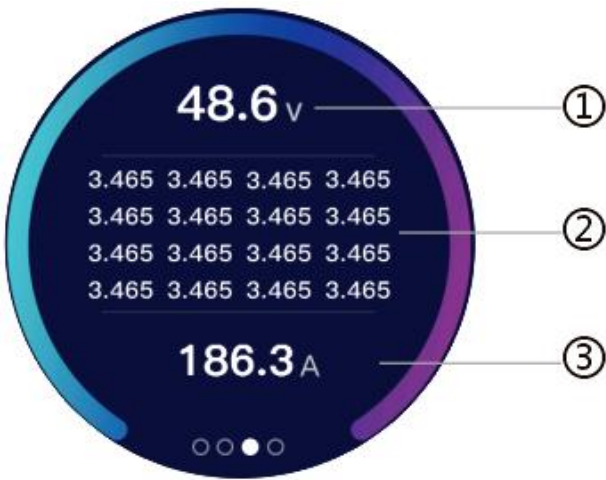

②	Cell voltage
③	Battery current

7.2.4.4 Information Page

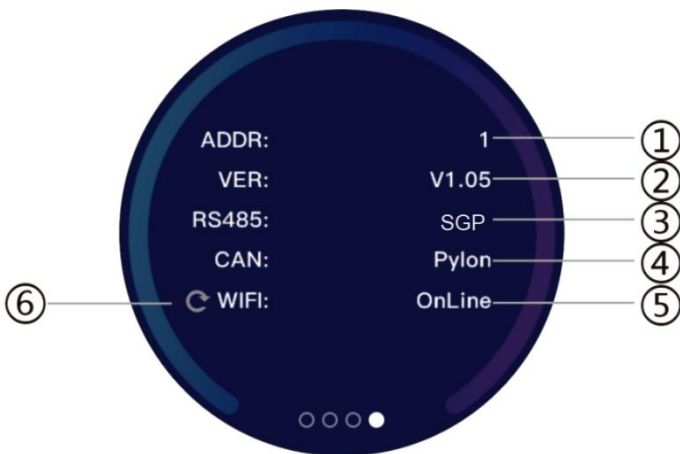

ID	Value
①	Battery address
②	Version
③	485 protocol connected with inverter
④	CAN protocol connected with inverter
⑤	WIFI status
⑥	Reset WIFI

If you can't connect to the network or need to change the network environment, please reset the WIFI.



7.3 Battery Communication Protocol

The supported inverter and battery manufacturer communication protocols are as follows, and will be continuously updated.

Battery /Inverter brand	CAN protocol	485 protocol
<i>Pylon</i>	√	√
<i>SUNGOLDPOWER</i>	√	√
<i>Growatt</i>	√	√
<i>Victron</i>	√	
<i>Goodwe</i>	√	
<i>Solis</i>	√	
<i>Luxpower</i>	√	
<i>Sofar</i>	√	
<i>KStar</i>	√	
<i>SMA</i>	√	
<i>MEGAREVO</i>	√	
<i>Afore</i>	√	
<i>Solark</i>	√	
<i>Voltronic</i>		√
<i>Paceic</i>		√

7.4 WIFI Function

7.4.1 Download App

Scan the QR code to download the APP.



7.4.2 Register and Login

You need to register an account for the first time.

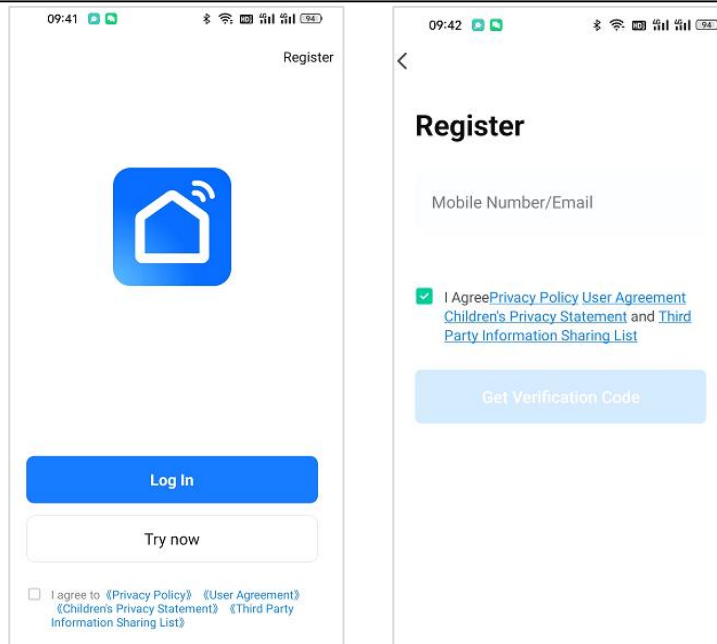

7.4.3 Add Device

Connecting the device requires turning on Bluetooth, WIFI, and location permissions.

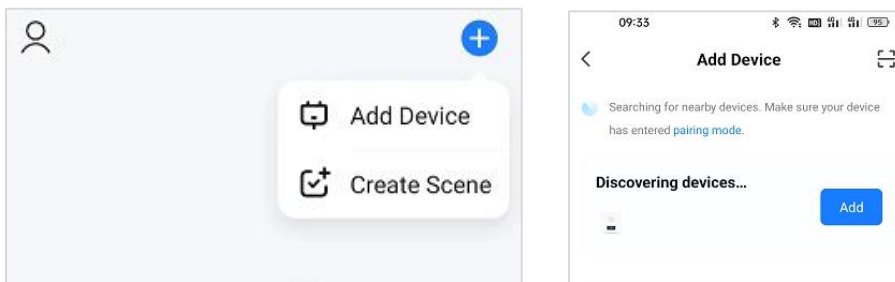

7.4.4 Connect Network

Choose WIFI and enter the password, the device starts connecting to the network.

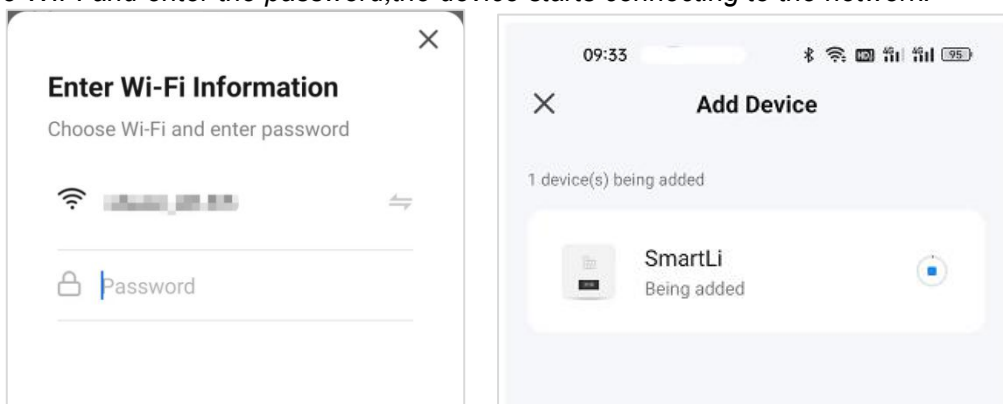

7.4.5 Reset WIFI

If you can't connect to the network or need to change the network environment, please reset the WIFI.



Only supports 2.4G band's WiFi , not supports 5G band's WiFi , please make sure that the 2.4G band of the router is turned on.

7.5 Sleep Mode

If the battery is neither charged nor discharged, it will automatically enter sleep mode after a period of time. After entering sleep mode, BMS will turn off LCD and WiFi module to save power. If you want to continue using it, please turn the power button on and off again.

8 System Maintenance

8.1 System Power-Off



After the system is powered off, the case still has residual power and heat, which may cause electric shocks or burns. Therefore, protective gloves should be worn before operating the energy storage 5 minutes after the system is powered off. Maintenance operations on energy storage should be performed only after ensuring that all indicator lights of the energy storage are off.

Power-off operation steps of the system:

Step 1 Turn off the breaker switch between the inverter and AC output (If installed).

Step 2 Turn off the breaker switch between the inverter unit and AC input (If installed).

Step 3 Turn off the breaker switch between the inverter unit and the PV string (If installed).

Step 4 Turn off the breaker switch between the inverter and battery.

Step 5 Turn off button on all storage battery modules, the energy storage is powered off successfully.

8.2 Routine Maintenance

To ensure the long-term and good operation of the energy storage system, it is recommended to perform the routine maintenance as described in this section.

Items	Methods	Maintenance interval
System cleanliness	Check if the radiator is covered or dirt on a regular basis.	Once every six months to one year.
Running status of system	<ul style="list-style-type: none"> Observe whether the energy storage appearance is damaged or deformed. Listen to whether the energy storage has any abnormal sound during running. When the energy storage is running, check whether the indicator of the energy storage battery is correct. 	Once every six months.
Electrical connection	<ul style="list-style-type: none"> Check if any cable connection is off or loose. Check if any cable is damaged, and especially if there are cuts on the sheath where the cable contacts with the metal surface. Check if the unused DC input terminals, energy storage terminals, COM ports, and covers are locked. 	Half a year after first debugging and testing, and once every six months to one year thereafter.

Grounding reliability	Check if the grounding cable is grounded reliably.	Half a year after first debugging and testing, and once every six months to one year thereafter.
-----------------------	--	--

8.3 Common Faults and Handling Methods

Faults	Handling measures
The indicator light and LCD does not work	Check whether battery is sleeping mode. If the battery is neither charged nor discharged, it will automatically enter sleep mode after a period of time.
All indicators of the battery are off	If the battery power is low, you need to charge it before using it. If the battery is not used for a long time, it will automatically sleep, and it can be used normally after restarting.
Battery overcurrent protection fault	Check whether there is a short circuit in the battery wiring. Check whether the load power exceeds the maximum
The battery cannot be charged	Check if the battery is fully charged Check whether the ambient temperature is below -10 degrees.
Communication error with inverter	Check whether the communication interface is incorrectly plugged in and Whether the wiring is secure. Whether the battery address is set correctly. Whether the protocol is secure.
WIFI communication error	Check if the router settings are correct Check whether the routing network is normal Check whether the router's 2.4G frequency band is turned on

8.4 Battery Storage and Maintenance

8.4.1 Battery Storage Requirements



Do not put the battery into fire. The battery may explode.

Do not open or damage the battery. The electrolyte flowing out from the battery is harmful to the skin and eyes. The electrolyte may also be toxic;

1. When being stored, the batteries shall be placed correctly in accordance with the marks on the packing case. Do not put them upside down or on the side.
2. When stacking up the battery packing cases, the stacking requirements on the outer package shall be met.
3. The batteries should be handled with care, and damage to batteries should be strictly prohibited.
4. Requirements for the storage environment:
 - Ambient temperature: -10°C to 55 °C, recommended storage temperature: 20°C to 30°C.
 - Relative humidity: 5%RH-80%RH.
 - Dry, well ventilated, and clean.
 - The corrosive organic solvents, gases and other substances shall be kept away.
 - Exposing to direct sunlight shall be avoided.

– The distance from the heat source should not be less than two meters.

5. When being stored, the battery shall be disconnected from the external connection. If there is an indicator light on the battery panel, the indicator light shall be off.

6. When the stored batteries are going to be delivered, the first-in first-out principle should be followed.

7. After the battery is produced and tested, it shall be recharged to at least 50% SOC before being stored. If the device will not be used for a long period of time, discharge the battery to 45% to 60% of the battery capacity and disconnect the battery output to avoid the battery runs out.

8. Do not touch the battery pack with wet hands.

9. Do not squeeze, drop, or pierce the battery.

10. The battery should always be disposed in accordance with local safety regulations.

11. The battery should be stored and recharged in accordance with this User's Manual.

12. Do not reverse polarity of the battery when storing or transporting the batteries, the batteries shall not be stacked up without protective packaging, and the number of stacked packed batteries should not exceed the number specified on the packaging.

13. All operators of the energy storage system shall comply with the user manual, installation and service manual, and quality assurance requirements. Any damage to the device resulting from neglecting or misreading of the user's manual, installation and service manual, and the quality assurance requirements will invalidate the product warranty.

8.4.2 Requirements for Charging of Battery

The batteries to be stored for a long period of time (unused, for more than 3 months) must be kept in a dry and cool place. The storage voltage is 51V~53V. The batteries should be stored in a clean environment of $23\pm 2^{\circ}\text{C}$ and humidity of 45%~75%. If the battery will be shelved and not used for a long period of time, it should be recharged every 3 months to ensure that the battery voltage is within the above range.

As for batteries and long-term storage, routine maintenance is required. Please charge the battery to 40% SOC at a current of 0.2C according to the requirements in the table below.

Ambient temperature for storage	Relative humidity for storage environment	Storage Time	SOC
$<-10^{\circ}\text{C}$	/	Prohibited	/
$-10\sim 25^{\circ}\text{C}$	5%~70%	≤ 12 months	$30\%\leq\text{SOC}\leq 60\%$
$25\sim 35^{\circ}\text{C}$		≤ 6 months	
$35\sim 45^{\circ}\text{C}$		≤ 3 months	
$>45^{\circ}\text{C}$	/	Prohibited	/

8.5 Device Cleaning

It is recommended to clean and maintain the product from time to time. When cleaning, the dust and stains on the product shall be removed with a piece of soft dry cloth or vacuum cleaner. The product shall not be cleaned with organic solvents, corrosive liquids and other cleaning products.

9 Product Dimensions and Packaging

9.1 Product Dimensions

The external dimensions of the energy storage battery module , PowerMax 314 Outdoor is 1048*460*271mm.

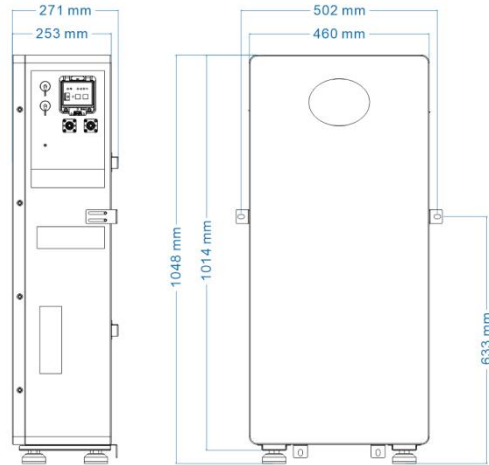

9.2 Package Dimensions

A single energy storage battery module. The packaging size of Power Max 314 Outdoor is 1170*600*510mm.

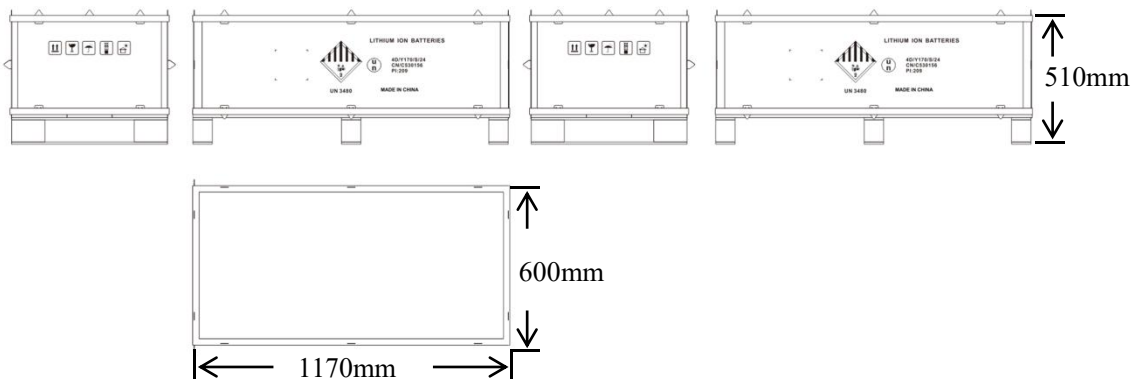



CONTACT US
(833)761-6080
support@sungoldpower.com

Rechargeable Lithium battery

Operation and Maintenance manual



Product Model: SGH48100T

Product Specifications: 51.2V 100Ah

Version: V-00

Content

1. Information	1
1.1 Validity	1
1.2 Target Group	1
1.3 Levels of warning messages	1
1.4 Symbol Description	2
1.4.1 Symbols on products label	2
1.4.2 Other symbols	3
1.5 Abbreviation Description	3
2. Safety	4
2.1 Safety precautions	4
2.2 Safety instructions	5
2.2.1 Safety gear	5
2.2.2 Emergency safety measures	5
2.2.3 Other Tips	6
3. Product Overview	7
3.1 Introduction	7
3.2 Features	8
3.3 Specification	9
3.3.1 Dimension	9
3.3.2 Parameters	9
3.3.3 Panel Interface	11
3.4 Protection function	14
4 Installation	16
4.1 Preparation	16
4.1.1 Safety Compliance	16
4.1.2 Environment	16
4.1.3 Tools	17
4.2 Inspection	18
4.2.1 Unpacking	18
4.2.2 Scope of delivery	18
4.3 Start Installation	20
4.3.1 Remainder	20
4.3.2 Procedures	21
4.3.3 Tips	21
5. Cable connection and commissioning	22
5.1 Get battery ready	22
5.2 Grounding cable connection	22
5.3 Communication cable connection	22
5.4 DC power cable connection	23
5.5 Connecting with inverter	24
5.6 Commissioning	27
5.7 Switch off battery	28

5.8 Troubleshooting and FAQ28

6. Transport, Storage30

7. Disposal of battery31

Appendix I31

1. Information

1.1 Validity

This document is valid for: SGH48100T Battery Pack.

1.2 Target Group

This document is intended for qualified persons and operators. Only qualified persons are allowed to perform the activities marked in this document with a warning symbol and the caption "Qualified person".

Qualified persons must have the following skills:

- Knowledge of how lithium iron phosphate batteries work and are operated.
- Knowledge of how an energy storage system (including PV/battery/hybrid inverter, MPPT, Meter, Distribution box etc.) works and is operated.
- Knowledge of local applicable connection requirements, standards, and directives.
- Training in the installation and commissioning of electrical devices, batteries.
- Training in how to deal with the dangers and risks associated with installing, repairing and using electrical devices, batteries.

1.3 Levels of warning messages

The following levels of warning messages may occur when handling the product

 **DANGER**

Indicates a hazardous situation which, if not avoided, will result in death or serious injury.

⚠ WARNING

Indicates a hazardous situation which, if not avoided, could result in death or serious injury.

⚠ CAUTION





Indicates a hazardous situation which, if not avoided, could result in minor or moderate injury or product permanent damage.

⚠ NOTICE

Indicates a situation which, if not avoided, can result in property damage or product not work or accelerated product damage



1.4 Symbol Description

1.4.1 Symbols on products label

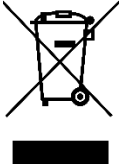
Label	Definition
	Beware of electrical shock
	Do not place the battery within children/pet touchable area.
	Do not place the battery near heat source and flammable material
	Do not expose the battery to direct sunlight, rain and snow.
	Do not short circuit the battery

	Recycle label
	WEEE designation

1.4.2 Other symbols

Label	Definition
 Qualified person	Indicates activities that can only be performed by qualified persons
	Grounding point

1.5 Abbreviation Description

Abbreviation	Definition
Battery/battery pack/battery module	Single SGH48100T rechargeable lithium iron phosphate battery pack including cells, BMS and enclosure etc.
Battery system/cluster	Multiple SGH48100T battery pack connected in parallel with power, communication and grounding cables and installation auxiliaries.
BMS	Battery management system Electronical Unit to ensure lithium cells' safety and display information or control the battery work mode.
SOC	State of charge The battery state of charge refers to the percentage of the remaining capacity and rated capacity of the battery.
SOH	State of health The battery health status refers to the percentage between the full charged capacity and the rated capacity of the battery.
DIP switch	Dual in-line package switch
COCP	Charge over current protection
DOCP	Discharge over current protection
COVP	Cell over voltage protection
POVP	Pack over voltage protection
CHTP	Charge high temperature protection
DHTP	Discharge high temperature protection

CUVP	Cell under voltage protection
PUVP	Pack under voltage protection
CLTP	Charge high temperature protection
DLTP	Discharge high temperature protection
SCP	Short circuit protection

2. Safety

2.1 Safety precautions

DANGER

Explosion risk

- Do not impact the battery with heavy objects.
- Do not squeeze or pierce the battery pack.
- Do not throw the battery pack into the fire.

WARNING

Fire risk

- Do not expose the battery pack to the condition over 80°C.
- Do not put the battery near a heat source, such as a fireplace.
- Do not expose the battery pack to direct sunlight or raining.

CAUTION

Electric shock risk

- Do not allow non-qualified person to disassemble the battery pack.
- Do not touch the battery pack with wet hands.
- Do not expose the battery pack to moisture or liquid environment.

NOTICE

Damage risk

- Do not short-circuit or reverse connect the battery.
- Do not use chargers or charging devices unapproved by the manufacturer to charge the battery.
- Do not mix batteries from different manufacturers or different kinds, types or brands.

2.2 Safety instructions

The battery has been designed and tested in accordance with international (such as UN38.3 etc.) safety requirements. However, due to various factors during the whole lifetime process, Manufacturer cannot guarantee absolute safety, in order to prevent personal injury and property damage and ensure long-term operation of the battery, please do read the below section carefully to operate the battery and handle emergency situations.

2.2.1 Safety gear

It is required to wear the following safety gear when installing and handling the battery pack.



Insulated gloves



Safety Glasses



Safety Shoes

2.2.2 Emergency safety measures

Water invasion

Please cut off the AC power supply of the system first and then disconnect all switched under the premise of ensuring safety.

Electrolyte or gas leakage

If the battery pack leaks electrolyte, avoid contact with the leaking liquid or gas. If one is exposed to the leaked substance, immediately perform the actions described below.

- Gas Inhalation: Evacuate the people in the contaminated area and seek medical aid immediately.

- Eye Contact: Flush your eye with clean and flowing water for 15 min, and seek medical aid immediately.
- Skin Contact: Thoroughly rinse the exposed area with soap and water to be sure no chemical or soap is left on them, and seek medical aid immediately.
- Ingestion: Induce vomiting, and seek medical help immediately.

 **WARNING**

In case of fire situations, please use carbon dioxide fire extinguisher rather than liquid to put out fires.

2.2.3 Other Tips

- All the product are strictly inspected before shipment, please contact your supplier for replacement if you notice there's any defectives such as swelling.
- Do not disassemble batteries and components, otherwise the manufacturer will not be responsible for any damage caused by unauthorized disassembly or repair.
- Do enable the battery to be safely grounded before use to make sure the system in safe and normal operation.
- Please ensure that the electric parameters of these devices are compatible mutually before connecting the battery to other devices.
- Please take the environmental factors into careful considerations to ensure that the system can work in a suitable condition as the environment and storage methods have a certain impact on the service life and reliability of this product.

3. Product Overview

3.1 Introduction

The SGH48100T battery is designed for residential application and works as a storage unit in the photovoltaic system. It is a 51.2V lithium battery system, with BMS inside. It could be operated in both on-grid, back-up and off-grid modes with compatible inverters. Below is the general schematic of an ac-coupled system with the batteries.

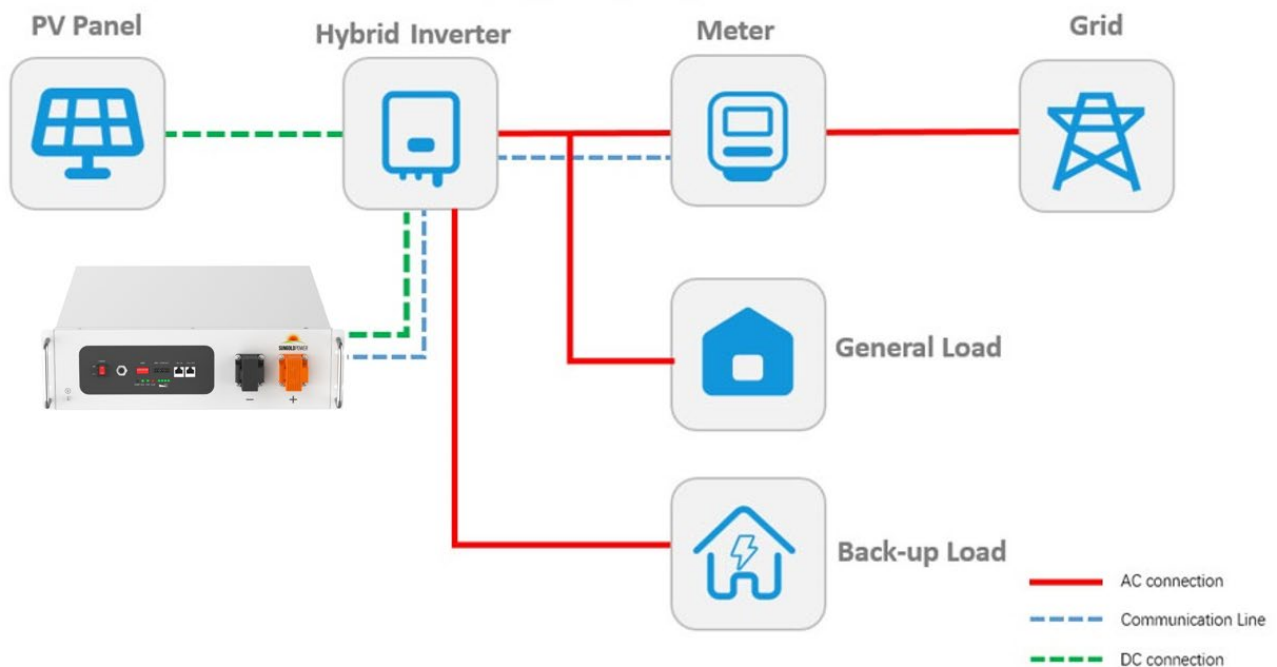

CAUTION

This electrical connection in this diagram is only for illustration, please follow the Manual suggestions of related devices and operate in accordance with locally

3.2 Features

- Highest safety, battery is made from LiFePO₄ chemistry and comply with highest international safety and transport standard.
- Modular and flexible, support up to 32 batteries connect together to expand the system energy.
- Built-in pre-charge circuit to avoid rush current when connecting with different inverter/chargers.
- Automatic dynamic addressing function when connected multiple batteries together.
- Support a maximum of 96% DOD under off-grid and back-up application
- Built in BMS provide warning and protection functions including over-discharged, over-charged, over-current, short-circuit and high/low temperature.
- LiFePO₄ as cathode material and automatic balancing function to meet longer cycle life
- Compact size and light weight for easy installation and maintenance.
- Multiple installation bracket to adopt with different customers' requirement.
- LED display, CAN/RS485 port for external communication and upgrade the BMS firmware.
- Rapid shutdown function for North American market.

3.3 Specification

3.3.1 Dimension

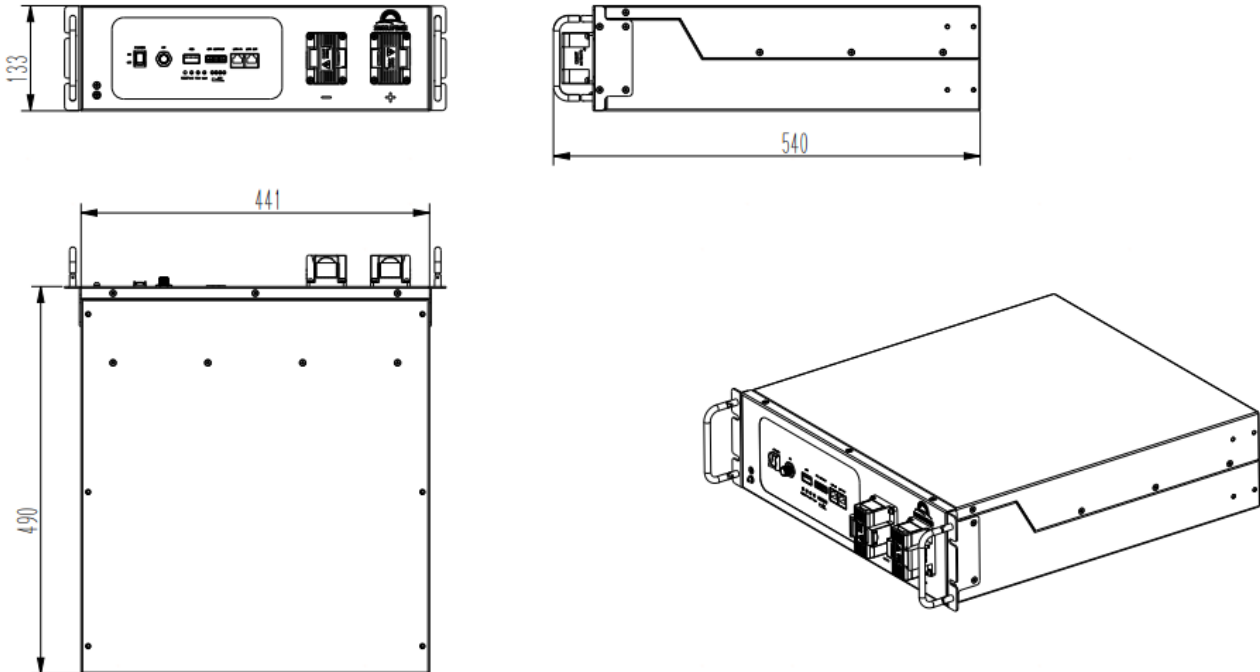

3.3.2 Parameters

Items	SGH48100T
Rated voltage	51.2V
Max. voltage range	44.8~57.6V, Shipping voltage>51.2V
Charge voltage	56.0V
Float charge voltage	54.6V
Nominal energy@0.5C	5.12KWh
Usable energy@0.5C	4.92kWh
Nominal capacity@0.5C	100Ah
Dimension	490*441*133mm (19.3*17.3*5.2 inch)
Weight	~47kg (103lb)
Standard charge current	≤50A
Max. charge current	70A
Standard discharge current	≤50A

Max. discharge current	100A (initial temp. $\leq 86^{\circ}\text{F}$ (30°C))	
Peak discharge current	101~119A@5mins 120~200A@15S	
Communication	RS485 /CAN	
Max parallel number	32pcs	
Operation temperature ¹	Charge: 14°F to 122°F ($-10\sim 50^{\circ}\text{C}$) Discharge: -4°F to 122°F ($-20\sim 50^{\circ}\text{C}$)	
Heating opening condition ²	-13°F (-25°C) $\leq T \leq 41^{\circ}\text{F}$ (5°C) @ $I \geq 0.08\text{C}$	
Heating completion condition ³	$T \geq 53.6^{\circ}\text{F}$ (12°C)	
Storage temperature @off mode	32°F (0°C) $< T < 86^{\circ}\text{F}$ (30°C)	< 6 months
	14°F (-10°C) $< T < 113^{\circ}\text{F}$ (45°C)	< 3 months
	Recommended environment	59°F to 95°F ($15\sim 35^{\circ}\text{C}$), 5~75%RH

NOTICE

1. The optimum operating temperature range is from 59°F to 86°F (15°C to 30°C), Frequent exposure to the harsh temperatures may worsen the performance of the battery pack and cycle life.
2. The current of the heating film is calculated in addition and is not added to the current detected by the BMS.
3. If the battery system is fully charged for the first time, the heating is stopped after a delay of 1 hour.
4. The heater operates within a temperature range of -13°F to 41°F (-25°C to 5°C).

Condition 1: When the battery temperature falls between 14°F to 41°F (-10°C to 5°C), the heater activates, initiating a low-current charging process. The heater will be off at 53.6°F (12°C), but regular charging of the battery continues.

Condition 2: In cases where the battery temperature is below 14°F ($< -10^{\circ}\text{C}$), the charging current is exclusively directed to the heating system until the battery temperature rises above 14°F (-10°C). Once this threshold is reached, the heater operates as described in Condition 1.

Please note that the heating system operation does not impact the State of Charge (SOC) of the battery.

3.3.3 Panel Interface

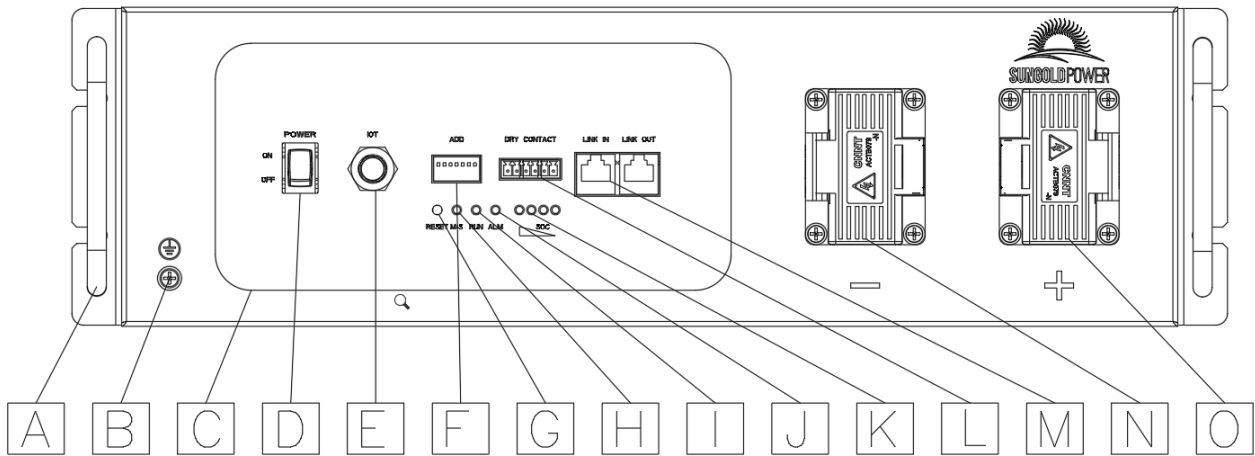

No.	Items	Usage description	Remark
A	Handles	For handling, installation and disassembly of battery	
B	Ground	Used to connect battery with ground	
C	PET	Decorative film	
D	Power switch	Used to Power on/off battery	
E	IOT	Used to connect with cloud platforms	
F	DIP	Used to set the RS485 baud rate and inverter protocol choosing	
G	Reset	Used to sleep(3s)/awake(3s)/reset(6~10s) BMS in power on mode.	
H	M/S	Used to indicate the module is Master or Slave battery	Single mode: OFF Parallel mode: ON- Master battery OFF- Slave battery
I	RUN	Used to show battery is in running status when lighting or flashing	
J	ALM	Used to show battery Alarm/Protection status	
K	SOC	Used to show battery real-time SOC	
L	Dry contact	1 channel input signal 2 channels output signal	
M	Link IN Link OUT	For internal and external communication	
N	Negative terminal	Used to connect the inverter/charger	
O	Positive terminal	Used to connect the inverter/charger	

3.3.3.1 L: Dry contact

PIN	Type
1	NO Output1, Charge enable/disable signal
2	
3	NO Output2, discharge enable/disable signal
4	
5	Passive INPUT signal.
6	Rapid Shutdown function for US

3.3.3.2 M: Link IN / Link OUT

Port	Pin No.	Definition	Remarks
Link IN	1	RS485-B1	1.Used to connect with external devices to establish communication. 2.Used to connect with upper battery pack Link OUT.
	2	RS485-A1	
	3	SGND	
	4	CAN-H	
	5	CAN-L	
	6	SGND	
	7	RS485-A1	
	8	RS485-B1	
Link OUT	1	RS485-B2	Used to connect with downward battery pack Link IN.
	2	RS485-A2	
	3	SGND	
	4	CAN-H	
	5	CAN-L	
	6	SGND	
	7	RS485-A2	
	8	RS485-B2	

3.3.3.3: DIP addressing

DIP							Remarks
RS485 baud rate	Undefined				Protocol		
1	2	3	4	5	6	7	
ON: 115200	Reserved for multiple cluster parallel and other future function				0	0	Protocol ID0
OFF: 9600					1	0	Protocol ID1
					0	1	Protocol ID2
					1	1	reserved
Keep all batteries the same setting	Keep default setting				Master: according to inverter Brand Slave: keep default setting		

Note:

Only the master battery needs to set the Protocol ID and keep all slave battery default settings after choosing the protocol ID, the battery will auto-detect the inverter information and corresponding to get into running, restart to take effect after setting a new DIP sequence.

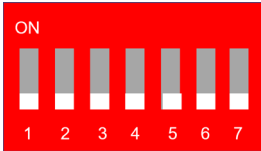
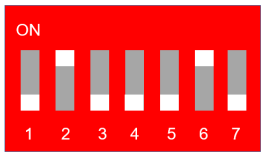
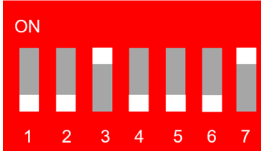
CANbus Connection		RS485 Connection		DIP setting (Master battery)
Protocol ID	INVERTER	Protocol ID	INVERTER	
CAN 1	Victron/SMA/Studer Innotec/Sofar	RS485 1	SUNGOLDPOWER SPH/Voltronic/RCT/ MPP/Alpha outback/ Phocos	 X000000
CAN 2	SUNGOLDPOWER SG /SolArk/Solis/Goodwe/Deye/ Growatt/SAJ/LUXPOWER/M egarevo/INVT/Sermatec/MU ST/Sunsynk	RS485 2	SUNGOLDPOWER SPH	 X100010
CAN 3	Schneider	RS485 3	LUX POWER	 X010001

NOTICE

Fail to follow the DIP switch setting will cause the communication fault between battery and inverter, for more detail setting with different inverter/charger, please contact your supplier for consultation.

3.3.3.4 RUN/ALM/SOC

Mode	Status	RUN	ALM	LED indicator				Description
		●	●	●	●	●	●	
Power off	-	OFF	OFF	OFF	OFF	OFF	OFF	All OFF
Standby	Normal	FLASH1	OFF	According to battery SOC				See note
	Warning	FLASH1	FLASH3					
Charge	Normal	ON	OFF	According to battery SOC (highest SOC LED: FLASH2)				See note
	Warning	ON	FLASH3					
	COCP	FLASH1	OFF	According to battery SOC				Stop charging
Discharge	Normal	FLASH3	OFF	According to battery SOC				See note
	Warning	FLASH3	FLASH3					
	CUVP/PUVP	OFF	FLASH3	OFF	OFF	OFF	OFF	Stop discharging
	DOCP	OFF	ON	OFF	OFF	OFF	OFF	Stop discharging
Temperature	CHTP/DHTP CLTP/DLTP	OFF	ON	OFF	OFF	OFF	OFF	Stop charging/dis charging
Failure	Cell/NTC failure Sensor failure MOS failure Reversed polarity /SCP	OFF	ON	OFF	OFF	OFF	OFF	Stop charging/dis charging

Note: 'Warning' including items of cell imbalanced/low voltage/high current/high&low temperature.

FLASH Type	ON	OFF
FLASH1	0.25S	3.75S
FLASH2	0.5S	0.5S
FLASH3	0.5S	1.5S

3.4 Protection function

Items	Description	Remark
Charge end COVP POVP	The BMS will stop charging if any cell or PACK voltage reach the protection value and it will be auto-released only when both Pack and cell voltage back to the release voltage range or there is efficient discharge current.	
Discharge end CUVP	The BMS will stop discharging if any cell or PACK voltage is under the protection value and it will be released only when all	Can Automatic recovery. Please charge

PUVP	the cell voltage back to the release voltage range or there is efficient charge current.	timely, otherwise it may be in Low-power mode to be over-discharged and damage battery.
CHTP DHTP	The BMS will stop charging or discharging or both if any cell/environment/MOS temperature is beyond the range.	Automatic recovery when temperature falls.
CLTP DLTP	The BMS will stop charging or discharging or both if any cell/environment/MOS temperature is under the range.	Automatic recovery when temperature rise.
COCP	The BMS will stop charging when the charging current is higher than the protection value. And it will release from the protection when the system delays time is met.	Automatic recovery. If locked after three consecutive times, manual intervention is required.
DOCP	The BMS will stop discharging when the discharging current is higher than the protection value. And it will release from the protection when the system delays time is met	Automatic recovery. If locked after three consecutive times, manual intervention is required.
SCP Reversed polarity	The BMS will stop charging when detect short circuit or reversed polarity.	Charge to release. Manual press reset.
Temperature, Voltage, Current sensor failure	Enter the failure mode, manual intervention is required no charging and discharging.	Manual intervention.
Sleep mode	After reaching a certain condition, BMS will enter dormancy mode to reduce BMS consumption	Charge, press reset or restart to activate.

CAUTION

Please re-charge the battery via MPPT, grid/generator or other energy source within 24h if the battery is over discharged, otherwise, it may be damaged.

NOTICE

Manually short-circuit and reverse the battery will void the warranty.

4 Installation

4.1 Preparation

4.1.1 Safety Compliance





The system installation must be finished by qualified person(s), During the whole installation process, please strictly follow the local safety regulations and related operating procedures.

4.1.2 Environment

The operating environment shall meet the following requirements:

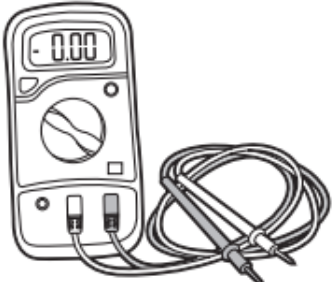
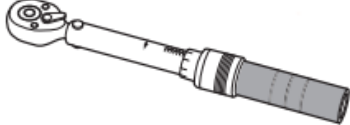
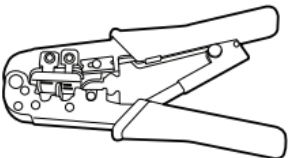
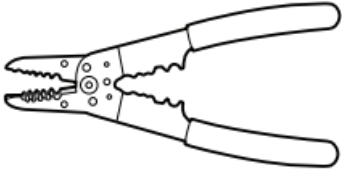
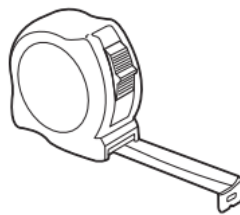
Category	Description
Working temperature	14 to 122° F(-10°C-50°C)(maximum operating range) 59 to 86° F(15°C-30°C) (optimal temperature)
Relative humidity	5%~90%, No condensation
Altitude	<3000m
Safety requirement	<ul style="list-style-type: none"> • Do not expose the battery to direct sunlight, rain and snow. • Do not place the battery within children/pet touchable area. • Do not place the battery near heat source and flammable material • Do not drop, deform, impact, cut or spearing with a sharp object. • Do not put heavy things on battery. • Do not disassemble the battery without Manufacturer's permission. • No conductive dust and water or other liquid to contact battery. • Follow the emergency measure if there is water invasion or electrolyte and gas leakage. • Contact your supplier within 24 hours if any product failure happens.

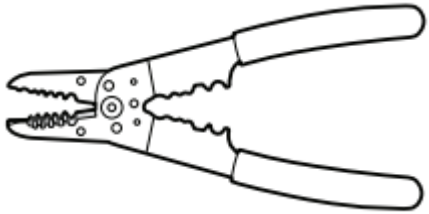
4.1.3 Tools

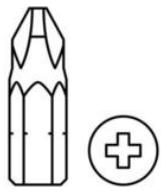
Tools	
<p>Torque screwdriver</p> 	<p>Multi-meter</p> 
<p>Torque wrench</p> 	<p>Cable crimper</p> 
<p>Wire stripper</p> 	<p>Tape measure</p> 
<p>Flat-head screwdriver</p> 	<p>Phillips-head screwdriver</p> 
<p>Wire stripper</p> 	<p>Drill</p> 
<p>Phillips-screwdriver bit</p> 	



4.2 Inspection

4.2.1 Unpacking

- Please load and unload it in accordance with the specified requirements to prevent sun and rain when you receive the equipment.
- Please check and confirm the goods (such as quantity, appearance, etc.) according to the "scope of delivery " before unpacking.
- Do light take and put during unpacking process to protect the surface coating of the object;
- Please record and feedback to the manufacturer if the inner packing is damaged after unpacking.

4.2.2 Scope of delivery

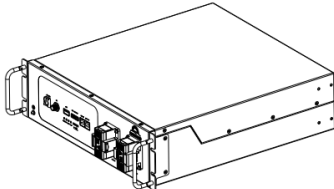
Check the scope of delivery for completeness and any externally visible damage. Contact your supplier for supplementary delivery if the listed material is incomplete or damaged.

General materials		
<i>(Battery unit)</i>		
 <p>Battery Pack *1pcs</p>		 <p>Manual *1pcs</p>
Type	Detail	Qty.
Rack mounted kits	A: Float nuts M6 	6pcs

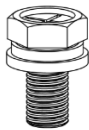
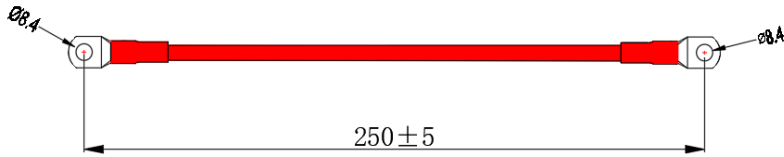
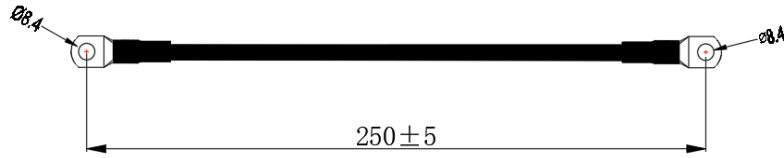
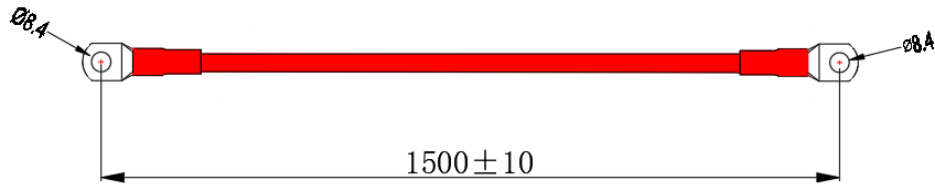
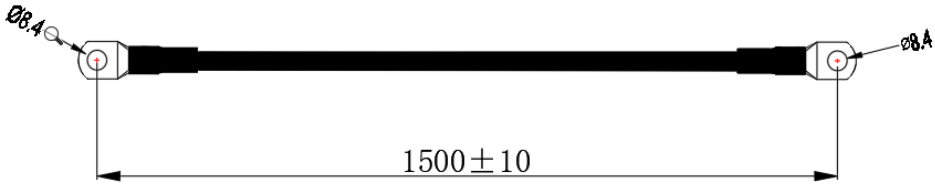
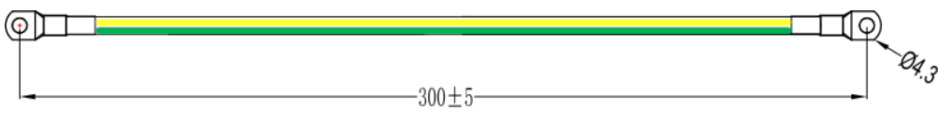
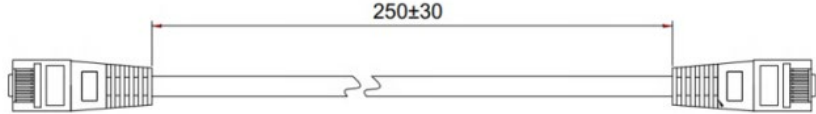
	<p>B: Combination Screw</p> <p>C: Hexagon bolt M8</p> 	<p>4pcs</p> <p>2pcs</p>
	 <p>250 ± 5</p>	<p>1pcs</p>
	 <p>250 ± 5</p>	<p>1pcs</p>
<p>Power cable</p>	 <p>1500 ± 10</p>	<p>1pcs</p>
	 <p>1500 ± 10</p>	<p>1pcs</p>
<p>Grounding cable</p>	 <p>300 ± 5</p>	<p>1pcs</p>
<p>Battery to battery communication cable</p>	 <p>250 ± 30</p>	<p>1pcs</p>

For inverter communication PIN definition detail, please check **Appendix I**

! NOTICE

Keep the unused cable pins NULL to avoid affecting the closed loop communication.

! NOTICE

A ground connection of communication cable may be required from some inverters, please follow the rules from inverter manufacture.

4.3 Start Installation

! Qualified person

4.3.1 Remainder

Please check again the following conditions or equipment whether meet the requirements before installation:

- Check if there's enough space for installation, and if the load-bearing capacity of the bracket or cabinet meets the weight requirements.
- Check whether the power cable pair(s) used meets the maximum current requirement for operation.
- Check whether the overall layout of power supply equipment and batteries at the construction site is reasonable.
- Check whether the installer is wearing anti-static wristband.
- Check whether there're two people on the construction site for installation work.
- Check if there's potential risks at location of installation site, e.g flooding, sun exposure, corrosion, and salt spray.

4.3.2 Procedures

⚠ CAUTION

Injuries may result if the product is lifted incorrectly or dropped while being transported or mounted.

Wear suitable personal protective equipment for all work on the product.

⚠ CAUTION

Ensure that no lines are laid in the wall which could be damaged when drilling holes.

4.3.2.1 Rack mounted

i. Take the battery pack out from carton.

ii. Get the Rack or cabinet ready and place it horizontally at a reasonable location.

iii. Place the battery on the rack or cabinet tray via manual-lift, Insert the screws and fasten the battery to the rack or cabinet

iv. Finish the cable connection

4.3.3 Tips

4.3.3.1 Installation not allowed

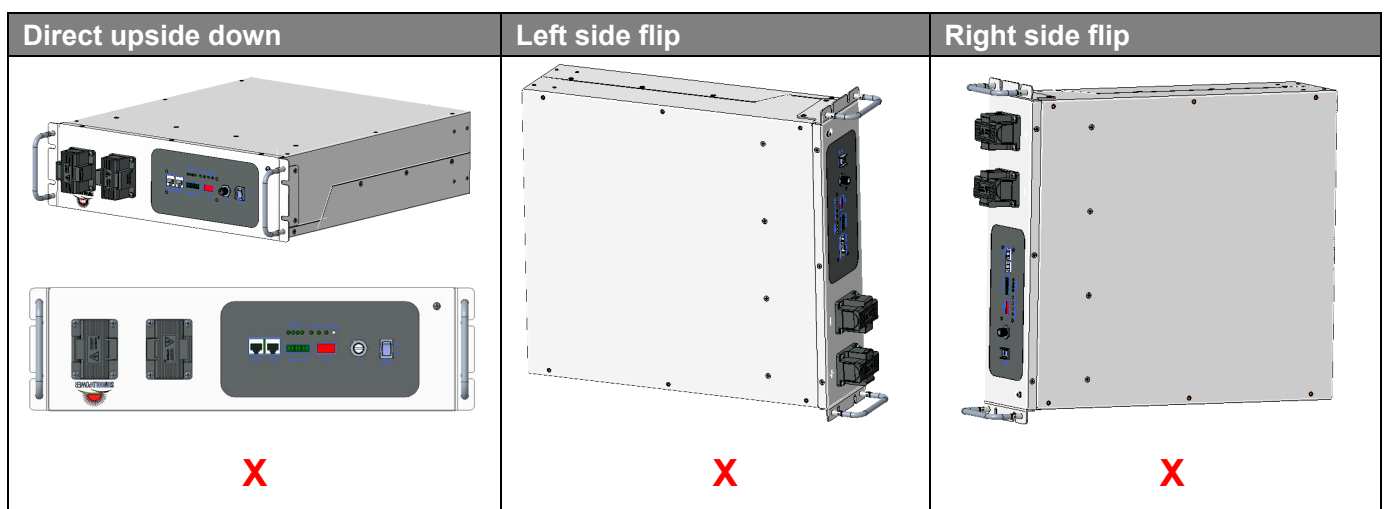

5. Cable connection and commissioning

5.1 Get battery ready

5.1.1 Ensure all the battery is in OFF mode, check and confirm the installation is tighten and stable.

5.1.2 Check the number and specification of cable kit accessories are correct according to the Scope of delivery item, if you are making cable yourself, please follow manufacturer's requirements.

5.1.3 Switch on all battery individually before wiring, check whether there is any alarm/protection information, if yes, turns to troubleshooting. Then switch off all batteries.

5.2 Grounding cable connection

5.2.1 Take out the grounding screw on the battery panel, and get the cable conductor through it.

5.2.2 Fix them together, with a cylinder screwdriver and tighten it.

5.2.3 Connect the grounding cable with next battery module.

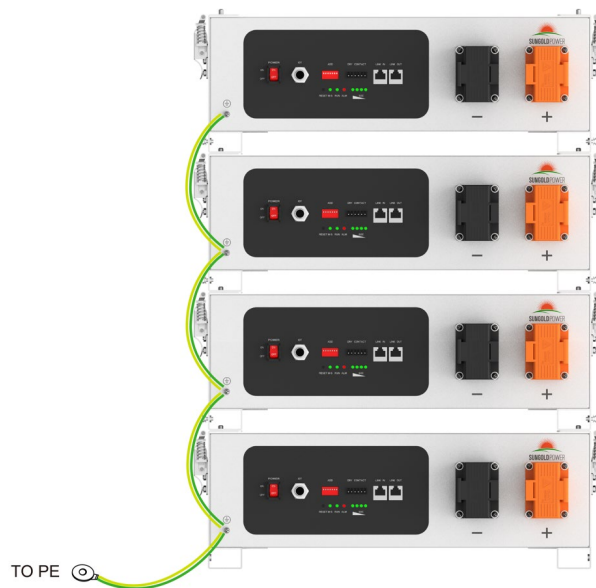

5.3 Communication cable connection

5.3.1 Take out battery to battery communication cable.

5.3.2 Confirm the location of Master battery, insert the RJ45 plug into the Link Out port and connect the other side to next battery Link IN port, daisy chained all batteries.

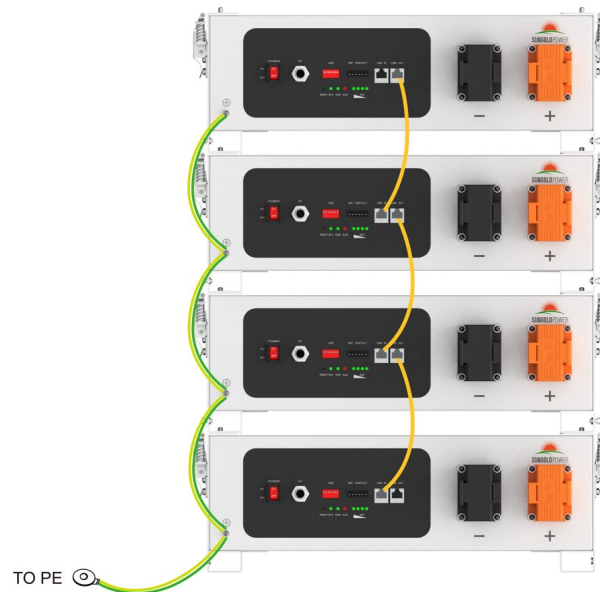

Note: the module with empty Link IN port is Master battery

⚠ NOTICE

The BMS inside the battery pack will automatically terminate BOTH end of CANBUS pins, DO NOT need to plug the 120 Ω terminator again.

5.4 DC power cable connection

5.4.1 Take out battery to battery power parallel cable.

5.4.2 Lock the terminals on the battery terminals and secure tightly with nuts.

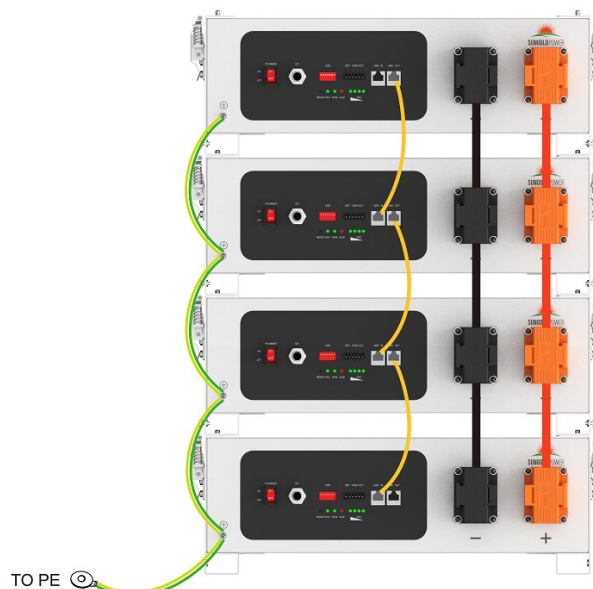

5.5 Connecting with inverter

⚠ CAUTION

Confirm inverter AC input and PV input is disconnected before wiring connection, and the DC/ signal switch of inverter/charger is in off status.

5.5.1 Connecting Master battery Link IN port with inverter CAN or RS485 communication port via inverter communication cable (*Version I/II/III or customized*).

5.5.2 Connecting battery OUTPUT (+) with inverter battery INPUT (+), battery OUTPUT (-) with inverter battery INPUT (-), an external disconnection breaker between battery system and inverter is recommended, choose the corresponding power cable pair and wiring them correctly.

Note:

⚠ NOTICE

Choose the suitable disconnection breaker considering the inverter power/current, rated voltage, tripping characteristic etc.

Wiring diagram allowed:

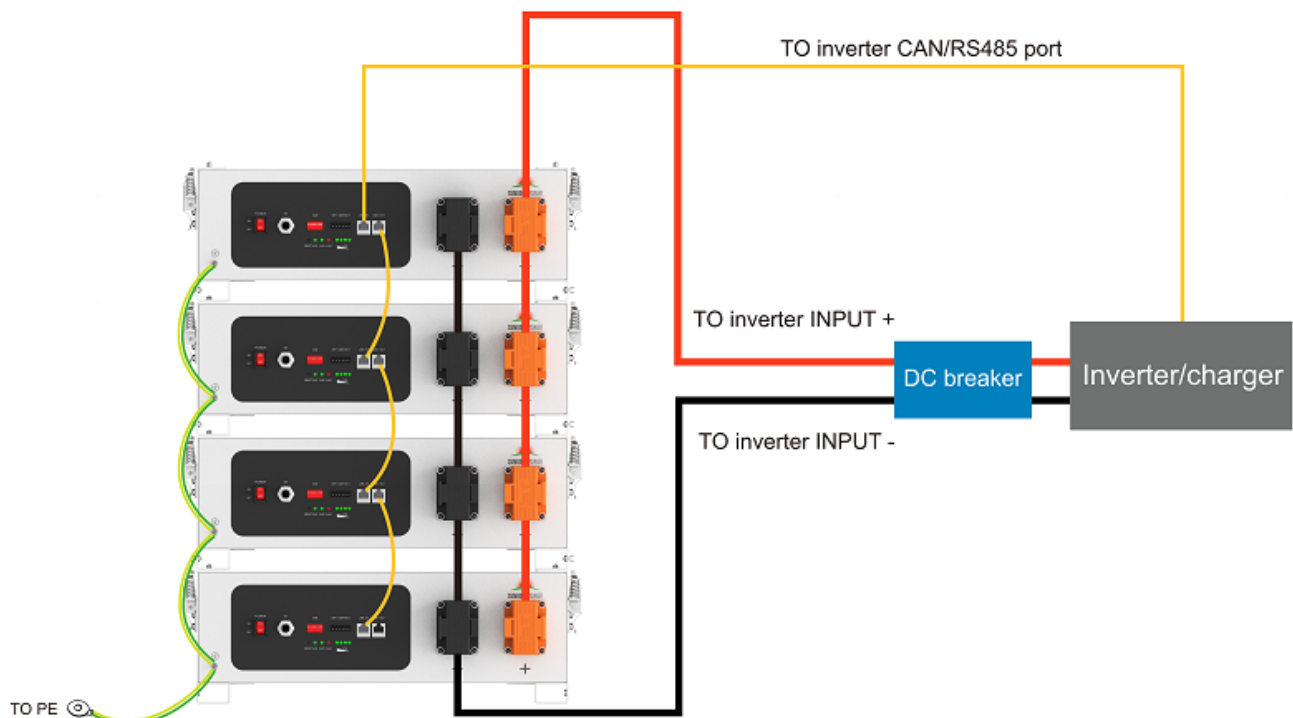

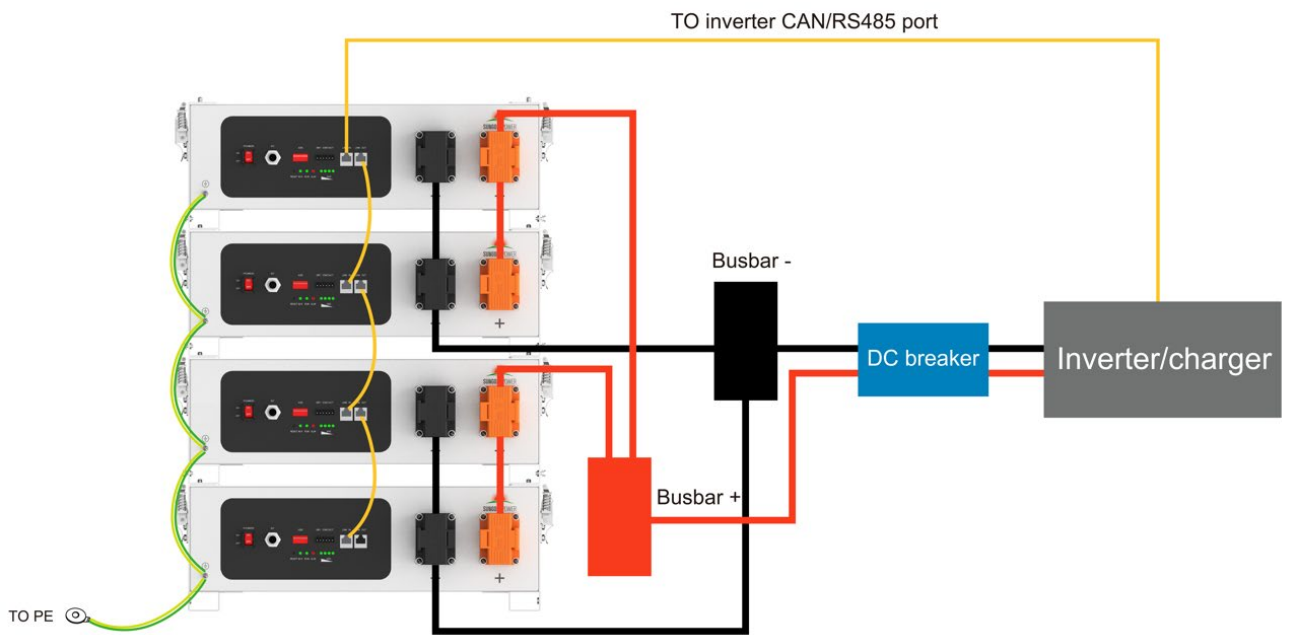
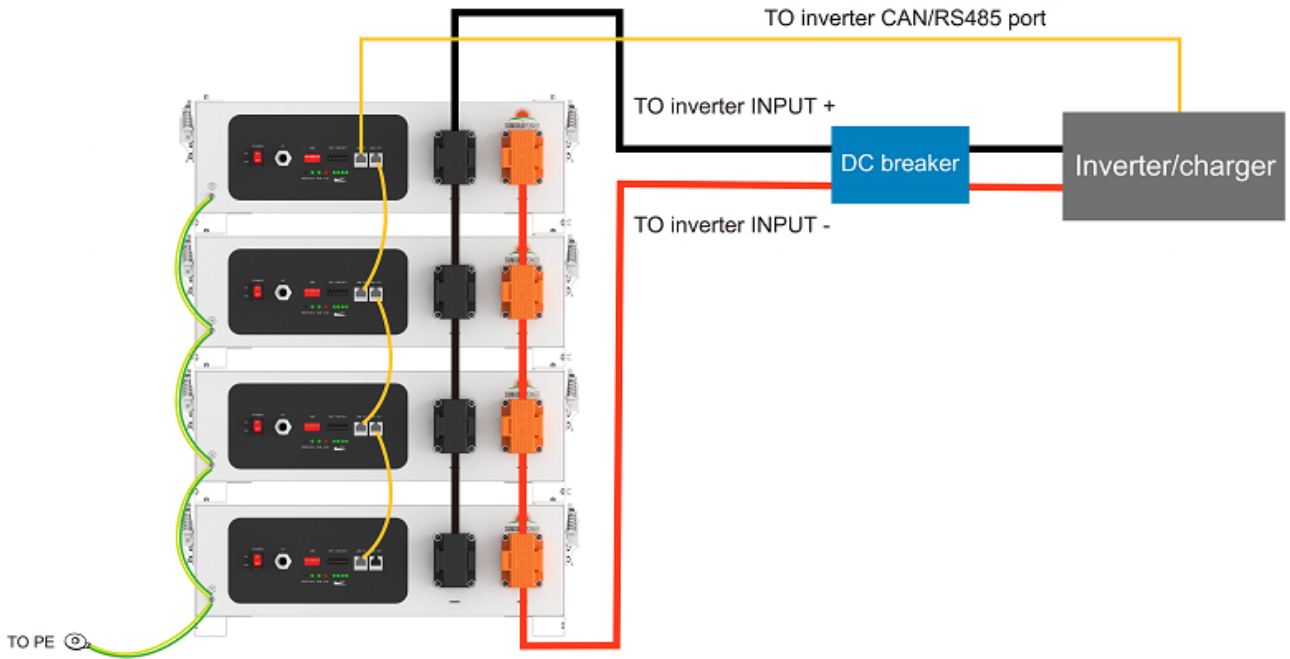

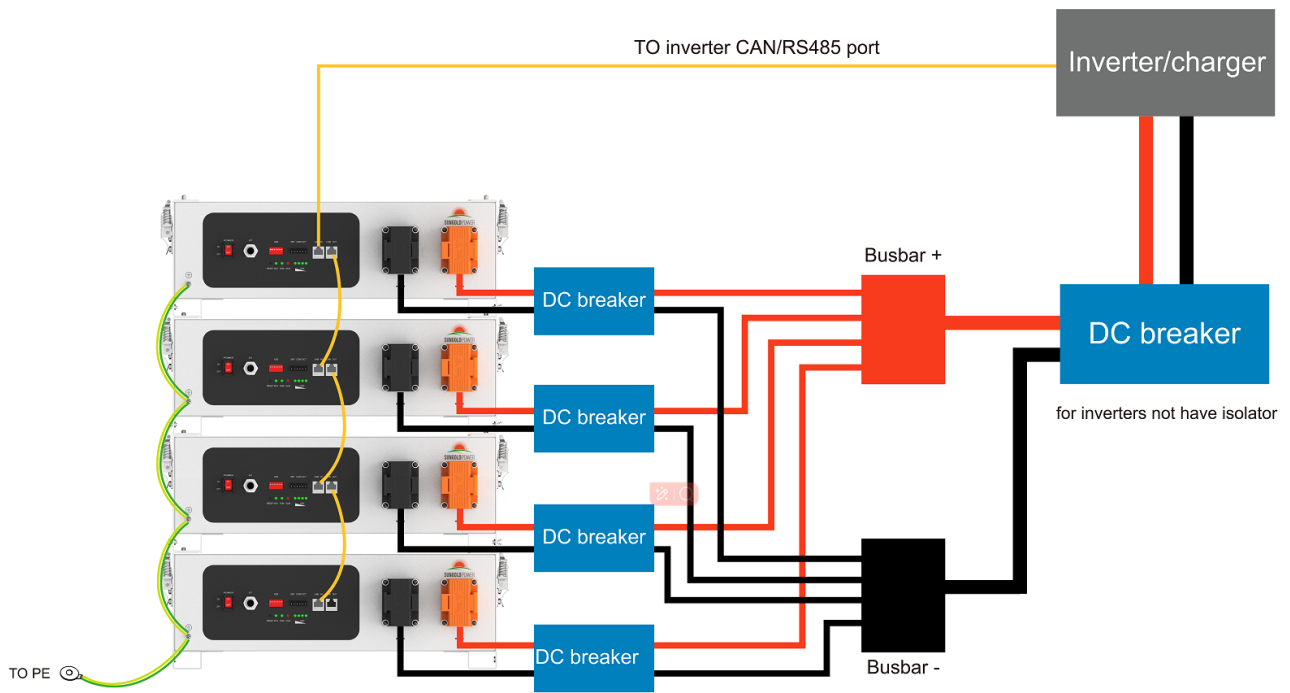

Wiring diagram not allowed:

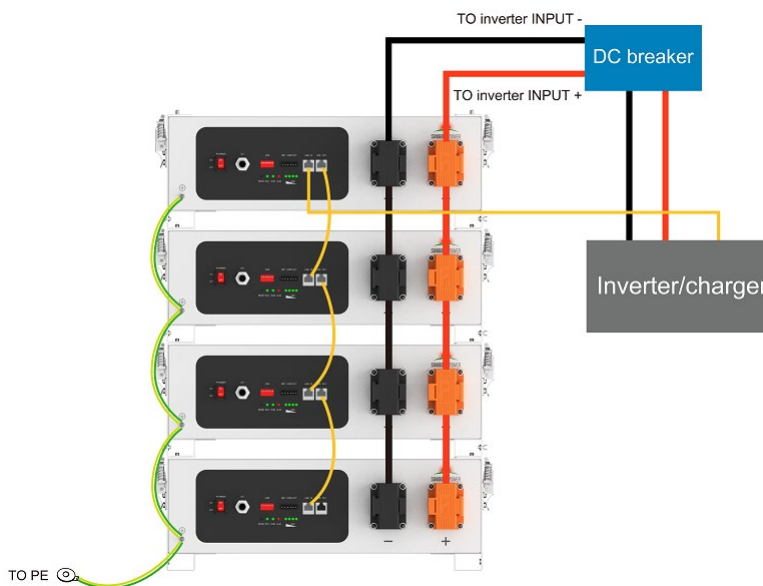

When multiple batteries are connected in parallel, the wires connecting the positive and negative electrodes of the inverter cannot come from the same battery. This connection mode will cause the current to be unevenly distributed among the batteries, resulting in differences in the SOC of the batteries.

! NOTICE

The maximum communication cable length is required to be less than 15m between inverter/charge and battery. The maximum power cable length is suggested to be less than 10m between inverter/charge and battery.

CAUTION

The maximum tolerance current of each power cable and terminal is 125A, 100A for continuously is suggested, please use corresponding number of power cable pairs according to the field configuration and local connection requirements, standards, and directives..

5.6 Commissioning

5.6.1 Set the DIP address of the Master battery (and the Slave battery if there is any RS485 baud rate changed).

5.6.2 Switch on all battery modules, wait for 10s, make sure that only M/S led is on Master battery.

5.6.3 Turn on the breaker between the inverter and battery if there is any, then turn on the inverter/charger isolator.

5.6.4 Finish the setting on inverter/charger or any other control devices, if everything is correct, you are ready to use the system.

No.	Inverter setting parameters	Detail
1	Absorption voltage	56.0V
2	Float voltage	54.6V
3	Re-charge/Generator start voltage	$\geq 50V$
4	Re-start voltage	52V
3	Low SOC limit (Grid-tied)	10/20% (differ from inverter brand)
5	Low SOC cut-off (Off-grid)	4%
6	Low Voltage cut-off	48.0V
7	Rated charging current limited value	100A*N (N is the Quantity of the battery pack)
8	Rated discharging current limited value	100A*N (N is the Quantity of the battery pack)
9	Max. charging current limited value	200A*N (N is the Quantity of the battery pack)
10	Max. discharging current limited value	200A*N (N is the Quantity of the battery pack)
11	Force charge/ Activate	Enable

For more information to connect with different inverter/charger, please contact your supplier for technical support.

CAUTION

If your system is a back-up or off-grid system, make sure your configuration can cover the worst situation to avoid battery to be over-discharged.

5.7 Switch off battery

5.7.1 Turn off the inverter.

5.7.2 Turn off the disconnection breaker if there is any.

5.7.3 Turn off all batteries signal switch.

5.8 Troubleshooting and FAQ

Items	Solution	Measure
Unable to start	<ol style="list-style-type: none"> 1. Power on battery and press RESET 6s to observe whether the battery can be started. 2. Charge the battery use a charger or inverter to provide 54~57.6V voltage and observe it can be started. 	<p>If the abnormal status still alive after above steps, please contact your supplier.</p> <p>If there is any other situation(s) excluding in this table, turn off the fault battery, contact your supplier.</p>
Unable to charge	<ol style="list-style-type: none"> 1. Check whether the cable connection between the battery and the inverter/charger is correct. 2. Check whether the inverter/charger setting is correct. 3. Check whether the battery is in charge protection mode, if yes, try to discharge the battery. 	
Unable to discharge	<ol style="list-style-type: none"> 1. Check whether the cable connection between the battery and the inverter/charger is correct 2. Check whether the battery occurs short circuit, reverse connection, pre-charge failure during connection inverter etc. 3. Check whether the battery is in discharge protection mode, if yes, try to charge the battery. 	
High/Low temperature	<ol style="list-style-type: none"> 1. Stop the battery system for a while, check whether the installation location temperature meet the requirement. 2. Avoid continuous full charging and discharging. 	
High current	Check the configuration and parameters setting on the inverter/charger is correct.	
ALM always on	<ol style="list-style-type: none"> 1. Check the fault information on the inverter APP or display if possible. 2. Ask your supplier to offer BMS monitoring software to locate the reason and back to them for solution. 	
Communication fail	<ol style="list-style-type: none"> 1. Check the communication cable type is correct and is contacted well. 2. Check the DIP switch setting is correct. 3. Check the inverter protocol related setting is correct. 4. Check both battery and inverter are working properly. 	

Q1: Battery maximum SOC is 98~99% and never goes to 100% SOC during daily cycle use, why?

This is normal and have no influence on capacity, usually BMS will calibrate the SOC to 100% when

reached cut-off current or trigger HVP, however, to avoid battery from being overcharged and to extend the cycle life as longer as possible, we left a room and set a charging profile to let battery charge slowly near full, please float the battery about 0.5~1 hour to calibrate the SOC.

Q2: 'High voltage' and 'cell unbalance' warning and alarm in rare cases, does it mean battery is damaged?

No. This is not unusual and happened on new batteries that are not balanced yet, please lower the maximum charge voltage (54.6V) and float the battery via grid or generator. If not solved, please contact your supplier.

Q3: When having multiple batteries in parallel connection, the battery on the end can't be fully charged.

Pay attention to your wiring diagram, please always follow the manual wiring advises and choose proper cable size and pair.

Q4: The current is 0A when connecting with a very small load at the situation that having multiple batteries in parallel connection, how to solve it?

Each BMS has a threshold current of 0.5A (~25W) before it begins to report, this leads the inaccurate display of the current.

Q5: SOC is not accurate or suddenly jumps to 100% during charging.

This mostly happen in off-grid applications on batteries that have not been calibrated SOC for a long time or situations that are similar to Q4 that with inverter in Idle mode or a small DC load or store the battery for a long time, we suggest fully charging at once the batteries per month refer to Q1.

Q6: The system is still running when the inverter log shows 'internal failure' warning.

This is our logic and this warning flag indicates there is 1 or more module(s) is in communication offline from the system, the system will derating and until communication is recovered.

Q7: Inverter pulling power from Grid to charge batteries in self-consumption mode.

When reached certain conditions such as low state of charge etc., battery will send charge request to ask inverter to charge the batteries, to avoid this, please discharge DOD as manual suggested.

6. Transport, Storage

- Do not violently shake, impact or squeeze, and prevent sun and rain during the transportation.
- Do light take and put and strictly prevent falling, rolling, and heavy pressure during loading and unloading.
- The battery should be placed in a dry, clean, dark, and well-ventilated indoor environment for long-term storage, and the recommended storage temperature range is 15~30°C.
- No harmful gases, flammable and explosive products and corrosive chemical substances in the storage location.
- The batteries should be stored and transported in close to 50% SOC, do not store over 80% SOC for long time.
- If do not use for a long time, the battery needs to be charged every 6 months.
- No fall down, no pile up over 6 layers, and keep face up.

7. Disposal of battery

Disposal of battery must comply with the local applicable disposal regulations for electronic waste and used batteries, please review your local Battery recycling or management regulations or contact your supplier for more information.

Appendix I

Connect with SUNGOLDPOWER SPH/SG inverter/charger

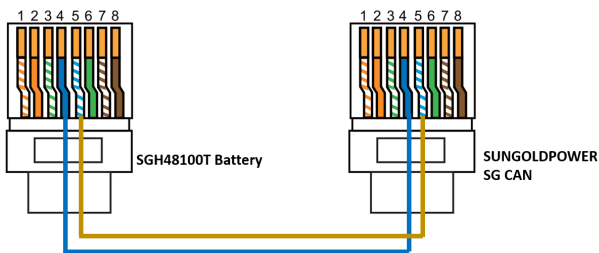

Battery CAN port	SUNGOLDPOWER SG CAN	Cable suggest
Pin4	Pin4	Version-II(CAN)
Pin5	Pin5	

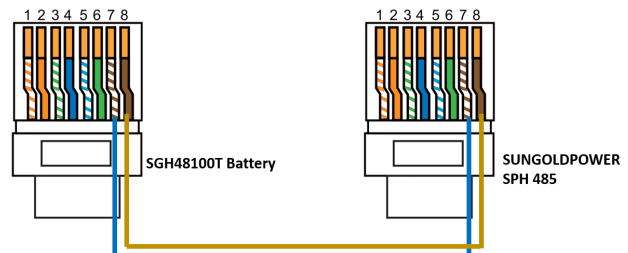

Battery RS485 port	SUNGOLDPOWER SPH 485	Cable suggest
Pin7	Pin7	Version-II(485)
Pin8	Pin8	

Connect with Victron GX & inverter/charger

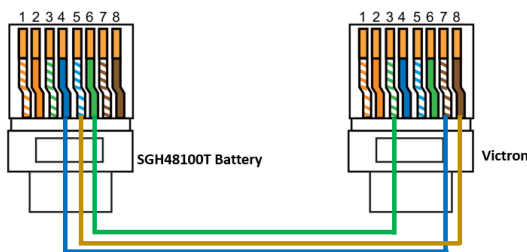

Battery CAN port	Victron VE.CAN/BMS CAN	Cable suggest
Pin4	Pin7	Version-I(CAN)
Pin5	Pin8	
Pin6	Pin3	

Connect with SMA inverter/charger

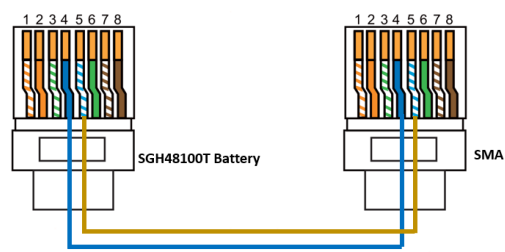

Battery 485 port	SMA sunny island	Cable suggest
Pin4	Pin4	Version-II(CAN)
Pin5	Pin5	
Pin6 (optional)	Pin2 (optional)	

Connect with Schneider inverter/charger

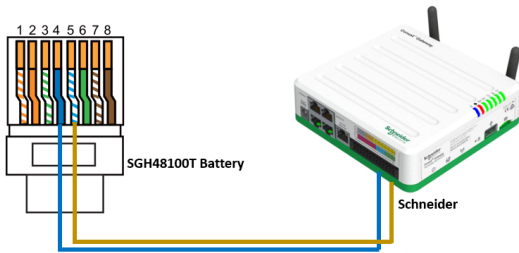

Battery CAN port	Conext Gateway	Cable suggest
Pin4	Pin14	customized
Pin5	Pin12	
Pin6 (optional)	Pin10 (optional)	

Connect with Studer inverter/charger

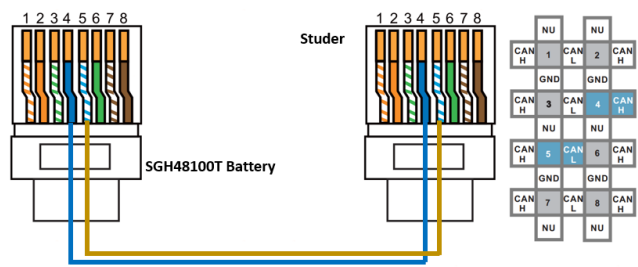

Battery CAN port	X-Com CAN	Cable suggest
Pin4	Pin4	Version-II(CAN)
Pin5	Pin5	

Connect with GOODWE hybrid inverter

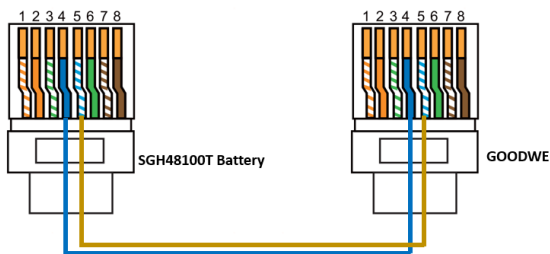

Battery CAN port	GOODWE BMS CAN	Cable suggest
Pin4	Pin4	Version-II(CAN)
Pin5	Pin5	

Connect with Sol-Ark hybrid inverter

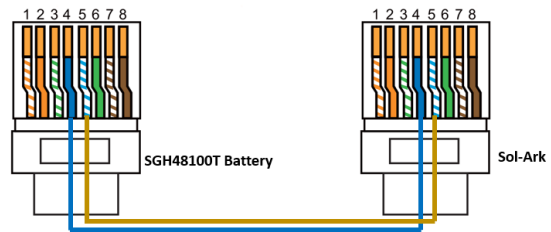

Battery CAN port	Sol-Ark CAN	Cable suggest
Pin4	Pin4	Version-II(CAN)
Pin5	Pin5	
Pin6 (optional)	Pin6 -outdoor Pin2 -indoor (optional)	

Connect with Growatt inverter

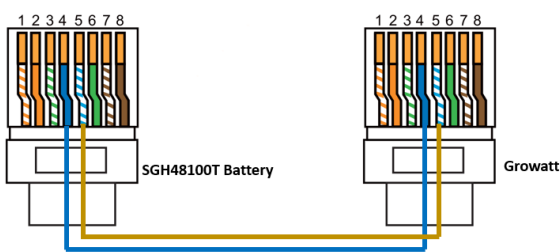

Battery CAN port	Growatt BMS communication port	Cable suggest
Pin4	Pin4	Version-II(CAN)
Pin5	Pin5	

Connect with Solis inverter

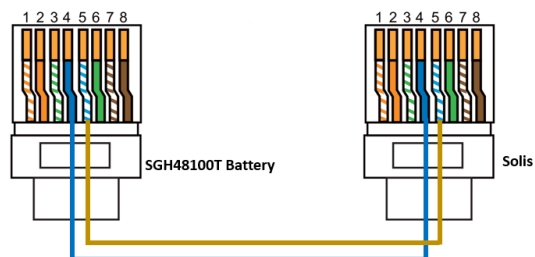

Battery 485 port	SMA sunny island	Cable suggest
Pin4	Pin4	Version-II(CAN)
Pin5	Pin5	

Connect with Deye hybrid inverter

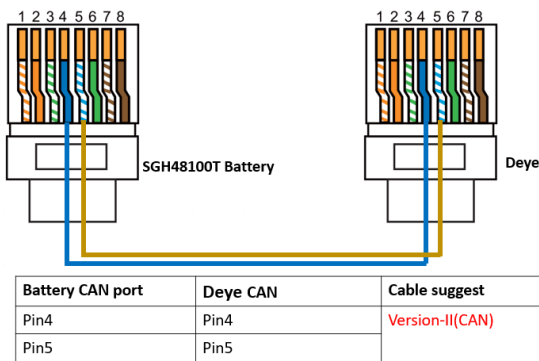

Connect with SUNSYNK hybrid inverter

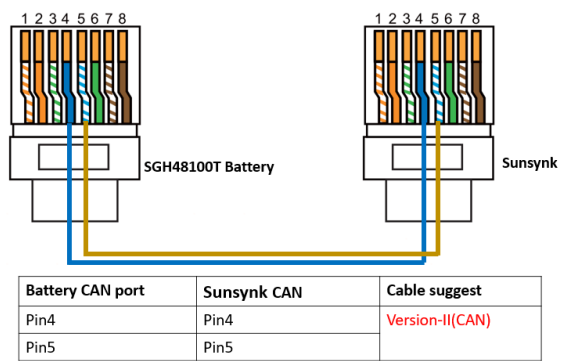

Connect with SAJ hybrid inverter

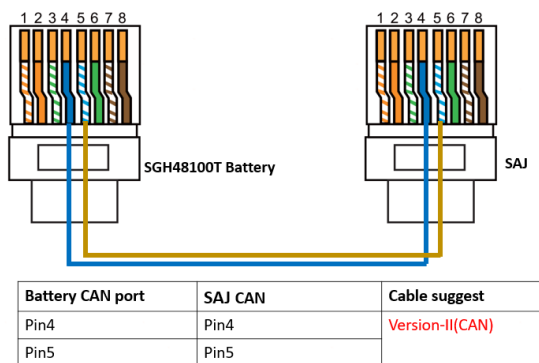

Connect with LUXPOWER inverter

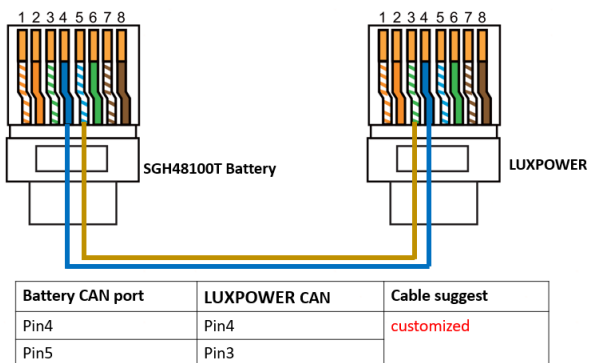

Connect with Megarevo/INVT inverter

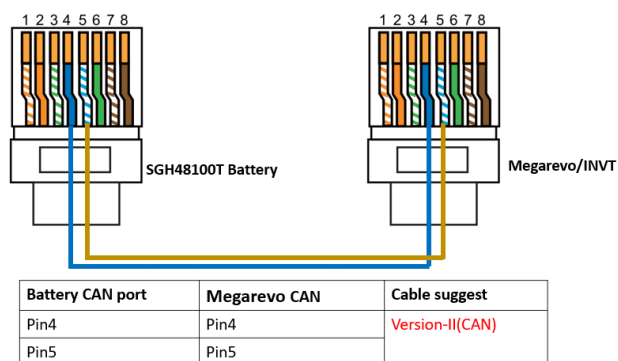

Connect with MUST inverter

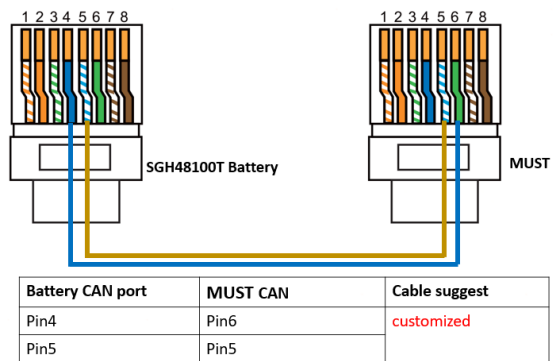

Connect with Alpha & Outback energy inverter

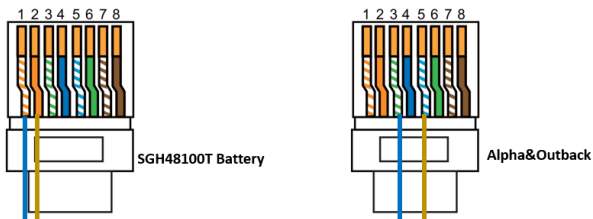

Battery RS485 port	Alpha&Outback BMS communication	Cable suggest
Pin1	Pin3	Version-III(RS485)
Pin2	Pin5	

Connect with Voltronic inverter

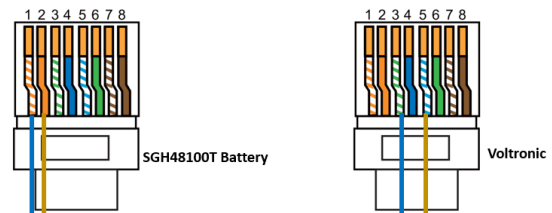

Battery RS485 port	Voltronic BMS communication	Cable suggest
Pin1	Pin3	Version-III(RS485)
Pin2	Pin5	

Connect with Phocos inverter

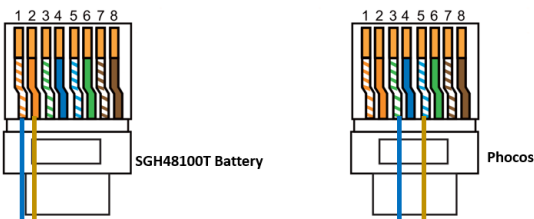

Battery RS485 port	Phocos BMS communication	Cable suggest
Pin1	Pin3	Version-III(RS485)
Pin2	Pin5	

Connect with Mpp solar inverter

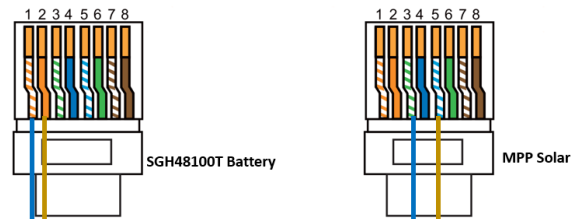

Battery RS485 port	MPP BMS communication	Cable suggest
Pin1	Pin3	Version-III(RS485)
Pin2	Pin5	